

MPU DX COIL

DRAWINGS

8/25/2011

Revision History				
#	Description	Revised by	ECN#	Date
1	Added Suction Connection	WBG	1716	7/7/09
2	Added MPU1-5E and MPU2-8	WBG	2086	7/7/10
3	Added MPU-AC coils	AJK	2340	8/24/11

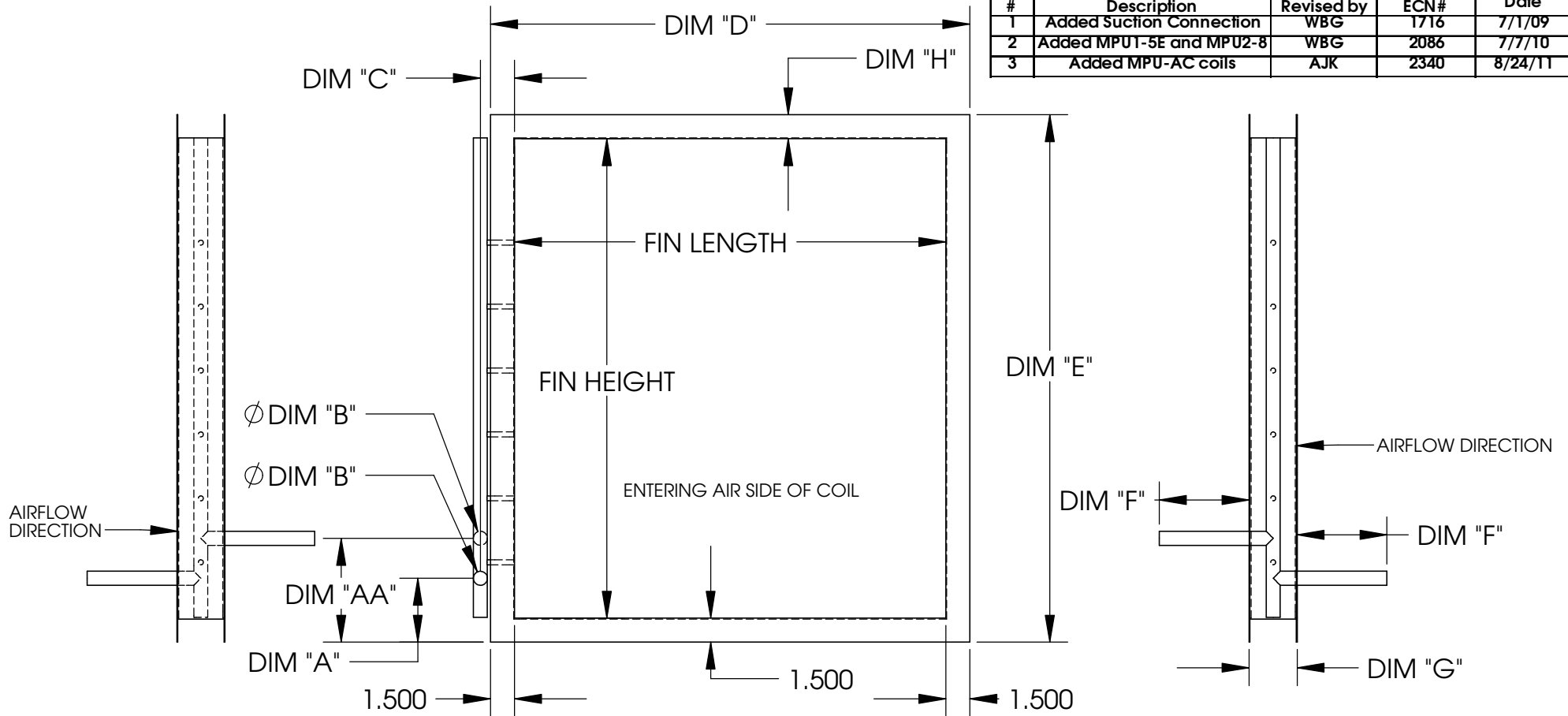

Single Circuit DX Information						
ID	MPU1-2	MPU1-3	MPU2-5	MPU1-2-AC	MPU1-3-AC	MPU2-5-AC
FIN HEIGHT	30	30	36	12	12	20
FIN LENGTH	27	27	36	27	27	36
DIM "A"	4	4	4	4	4	4
DIM "AA"	6.5	6.5	6.5	6.5	6.5	6.5
DIM "B"	0.75	0.875	0.875	0.75	0.875	0.875
DIM "C"	2.13	2.13	2.13	2.13	2.13	2.13
DIM "D"	30	30	39	30	30	39
DIM "E"	33	33	39	33	33	39
DIM "F"	5.62	5.62	5.62	5.62	5.62	5.62
DIM "G"	3.01	3.01	3	3.01	3.01	3
DIM "H"	1.5	1.5	1.5	19.5	19.5	17.5
TONNAGE	2	3	5	2	3	5
# OF CIRCUITS	1	1	1	1	1	1
LIQUID SIZE	0.5	0.5	0.625	0.5	0.5	0.625
HEATCRAFT #	2EZ0801M	2EZ1001N	3EZ1001R	2EY1102E	2EY1402E	3EY1102I

- Notes:
- 1) Distributor tubing bent toward leaving air side of coil.
  - 2) Liquid connection points vertically upwards. 3 inch extensions brazed to distributor.
  - 3) All suction connections to be capped. Cut suction tube required for MPU configuration.

Material: N/A  
Blank Size: N/A x N/A  
Weight: N/A lbs

**CONFIDENTIAL**

Part Number: N/A  
MACOLA Number: N/A  
Drawing Name: MPU DX Coil  
Drawn By: WBG  
Parent Assembly: MPU  
Sheet: 2 of 4

Unless Otherwise Specified  
Dimensions are in Inches.

Standard Tolerances are:  
Fractions: ±1/16  
Decimal: .XX±.05  
.XXX±.015  
Angles: ±1°

Revision History				
#	Description	Revised by	ECN#	Date
2	Added MPU1-5E and MPU2-8	WBG	2086	7/7/10
3	Added Size 4	AJK	2176	11/8/10
4	Added MPU-AC Coils	AJK	2340	8/25/11

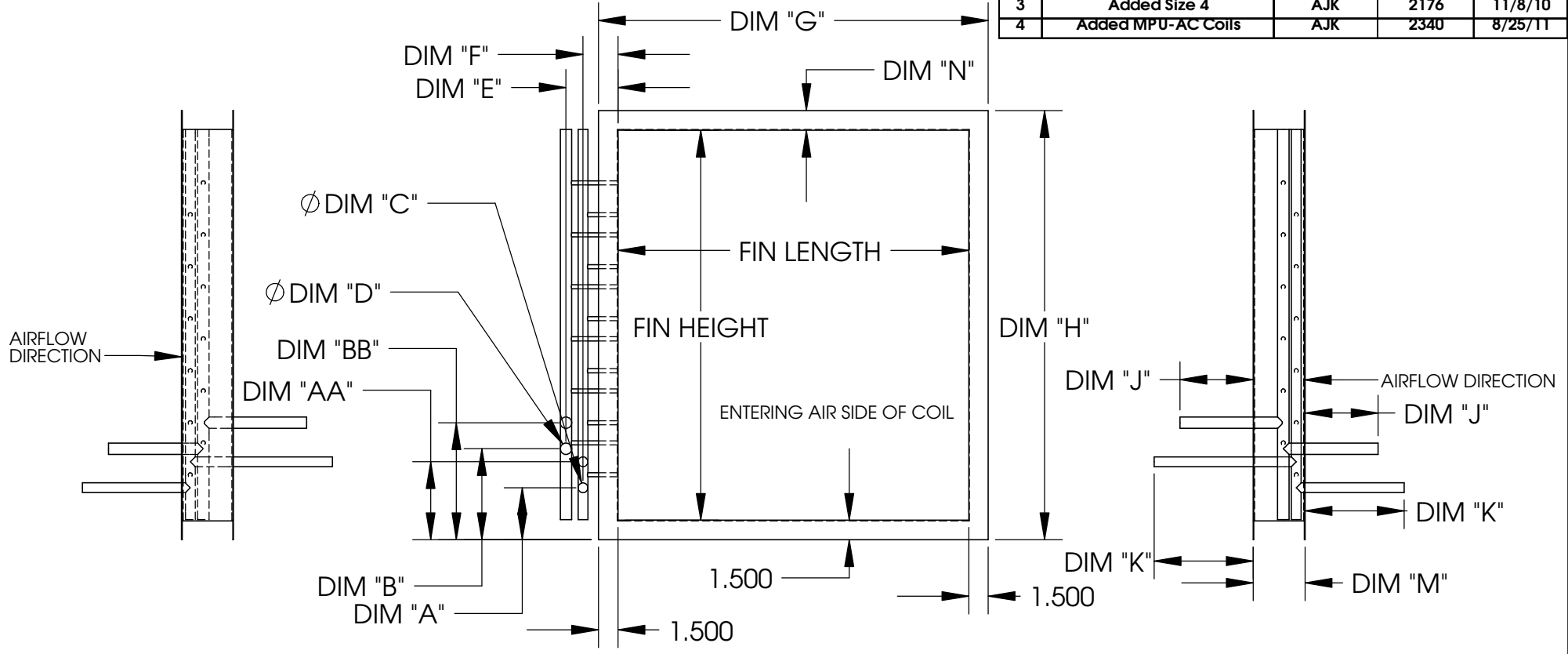

ID	Two Circuit DX Information												
	MPU1-5	MPU1-5E	MPU2-7.5	MPU2-8	MPU2-10	MPU3-10	MPU4-10	MPU1-5-AC	MPU1-5E-AC	MPU2-7.5-AC	MPU2-8-AC	MPU2-10-AC	MPU3-10-AC
FIN HEIGHT	30	30	36	36	36	43	52.5	12	12	20	20	36	43
FIN LENGTH	27	27	36	36	36	42	48	27	27	36	36	36	42
DIM 'A'	4	4	4	4	4	4	4	4	4	4	4	4	4
DIM 'AA'	6	6	6	6	6	6	6	6	6	6	6	6	6
DIM 'B'	7	7	7	7	7	7	7	7	7	7	7	7	7
DIM 'BB'	9	9	9	9	9	9	9	9	9	9	9	9	9
DIM 'C'	0.75	0.75	0.75	0.875	0.875	0.875	0.875	0.75	0.75	0.75	0.875	0.875	0.875
DIM 'D'	0.875	0.75	0.875	0.875	0.875	0.875	0.875	0.875	0.75	0.875	0.875	0.875	0.875
DIM 'E'	4	4	4	4	4	4	4	4	4	4	4	4	4
DIM 'F'	2.69	2.69	2.69	2.69	2.69	2.69	2.69	2.69	2.69	2.69	2.69	2.69	2.69
DIM 'G'	30	30	39	39	39	45	51	30	30	39	39	39	45
DIM 'H'	33	33	39	39	39	46	55.5	33	33	39	39	39	46
DIM 'J'	5.62	5.62	5.62	5.62	5.62	5.62	5.62	5.62	5.62	5.62	5.62	5.62	5.62
DIM 'K'	7.62	7.62	7.62	7.62	7.62	7.62	7.62	7.62	7.62	7.62	7.62	7.62	7.62
DIM 'M'	4	4	4	4	3.99	4.01	4	4	4	4	4	3.99	4.01
DIM 'N'	1.5	1.5	1.5	1.5	1.5	1.5	1.5	19.5	19.5	17.25	17.5	17.5	20.5
TOTAL TONNAGE	5	5	7.5	8	10	10	10	5	5	7.5	8	10	10
#1 TONNAGE	2	2.5	2.5	3	5	5	5	2	2.5	2.5	3	5	5
#2 TONNAGE	3	2.5	5	5	5	5	5	3	2.5	5	5	5	5
#1 LIQUID SIZE	0.5	0.5	0.5	0.5	0.625	0.625	0.625	0.5	0.5	0.5	0.5	0.625	0.625
#2 LIQUID SIZE	0.5	0.5	0.625	0.625	0.625	0.625	0.625	0.5	0.5	0.625	0.625	0.625	0.625
# OF COILS	2	2	2	2	2	2	2	2	2	2	2	2	2
HEATCRAFT #	2EZ0902M	2EZ0902M	3EZ1101C	3EZ1101D	3EZ0802B	3EZ0602M	4EZ0801C	2EY1403E	2EY1403E	3EY1402I	3EY1302I	3EY1203I	3EZ1203I

- Notes:
- 1) Distributor tubing bent toward leaving air side of coil.
  - 2) Liquid connection points vertically upwards.  
3 inch extensions brazed to distributor.
  - 3) All suction connections to be capped.  
Cut suction tube required for MPU configuration.

Material: N/A	Part Number: N/A	Unless Otherwise Specified Dimensions are in Inches.
Blank Size: N/A x N/A	MACOLA Number: N/A	
Weight: N/A lbs	Drawing Name: MPU DX Coil	
<b>CONFIDENTIAL</b>	Drawn By: WBG Parent Assembly: MPU Sheet: 3 of 4	
		Standard Tolerances are: Fractions: ±1/16 Decimal: .XX±.05 .XXX±.015 Angles: ±1°

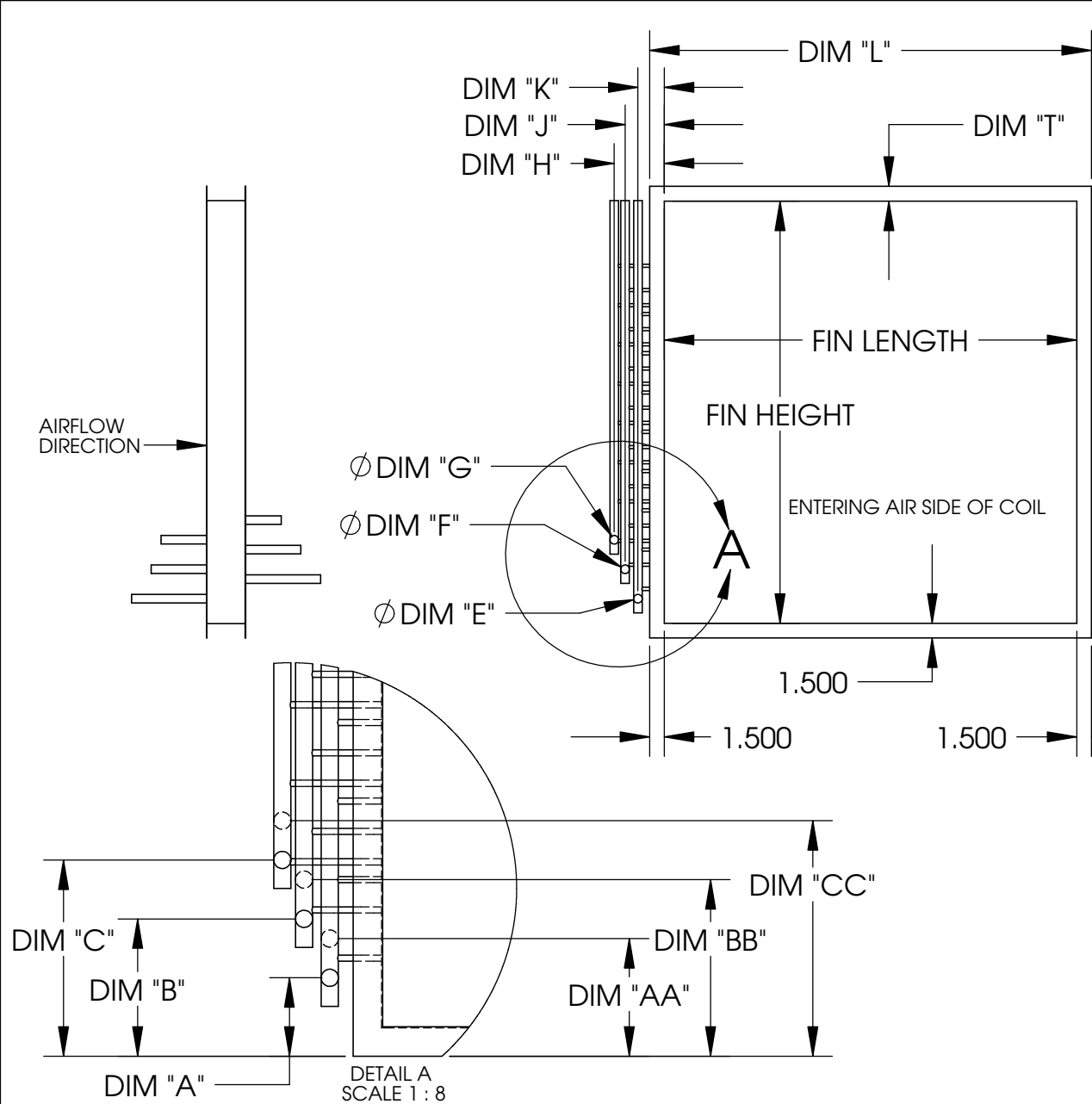

Revision History				
#	Description	Revised by	ECN#	Date
0	Released to production	WBG	2143	10/5/10
1	Created Size 4	AJK	2176	11/8/10
2	Added MPU-AC Coils	AJK	2340	8/24/11

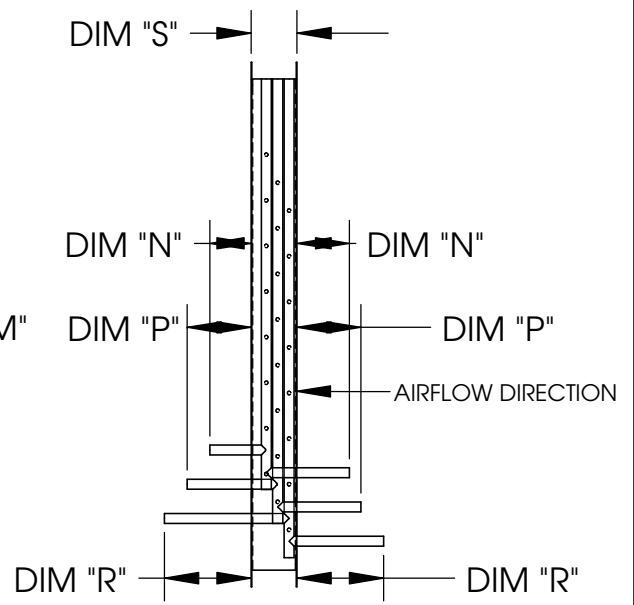

Three Circuit DX Information			
ID	MPU3-15	MPU4-15	MPU3-15-AC
FIN HEIGHT	43	52.5	30
FIN LENGTH	42	48	42
DIM 'A'	4	4	4
DIM 'AA'	6	6	6
DIM 'B'	7	7	7
DIM 'BB'	9	9	9
DIM 'C'	10	10	10
DIM 'CC'	12	12	12
DIM 'E'	0.875	0.875	0.875
DIM 'F'	0.875	0.875	0.875
DIM 'G'	0.875	0.875	0.875
DIM 'H'	5.108	5.108	5.108
DIM 'J'	4	4	4
DIM 'K'	2.69	2.69	2.69
DIM 'L'	45	51	45
DIM 'M'	46	55.5	46
DIM 'N'	3.62	3.62	3.62
DIM 'P'	5.62	5.62	5.62
DIM 'R'	7.62	7.62	7.62
DIM 'S'	4.49	5.09	4.49
DIM 'T'	1.5	1.5	14.5
TOTAL TONNAGE	15	15	15
#1 TONNAGE	5	5	5
#2 TONNAGE	5	5	5
#3 TONNAGE	5	5	5
#1 LIQUID SIZE	0.625	0.625	0.625
#2 LIQUID SIZE	0.625	0.625	0.625
#3 LIQUID SIZE	0.625	0.625	0.625
# OF CIRCUITS	3	3	3
HEATCRAFT #	3E21002B	4EZ0602B	3EY1403T

- Notes:
- 1) Distributor tubing bent toward leaving air side of coil.
  - 2) Liquid connection points vertically upwards. 3 inch extensions brazed to distributor.
  - 3) All suction connections to be capped. Cut suction tube required for MPU configuration.

Material: N/A  
 Blank Size: N/A x N/A  
 Weight: N/A lbs

**CONFIDENTIAL**

Part Number: N/A  
 MACOLA Number: N/A  
 Drawing Name: MPU DX Coil  
 Drawn By: WBG  
 Parent Assembly: MPU  
 Sheet: 4 of 4

Unless Otherwise Specified  
 Dimensions are in Inches.

Standard Tolerances are:  
 Fractions: ±1/16  
 Decimal: .XX±.05  
 .XXX±.015  
 Angles: ±1°