

Installation, Operation, and Maintenance Manual



RECEIVING AND INSPECTION

Upon receiving unit, check for any interior and exterior damage, and if found, report it immediately to the carrier. Also check that all accessory items are accounted for and are damage free.

WARNING!!

Installation of this module should only be performed by a qualified professional who has read and understands these instructions and is familiar with proper safety precautions. Improper installation poses serious risk of injury due to electric shock and other potential hazards. Read this manual thoroughly before installing or servicing this equipment. **ALWAYS** disconnect power prior to working on module.

Save these instructions. This document is the property of the owner of this equipment and is required for future maintenance. Leave this document with the owner when installation or service is complete.

TABLE OF CONTENTS

WARRANTY.....	4
INSTALLATION.....	5
Mechanical.....	5
Plumbing Connections for Self Cleaning.....	5
Piping Loss Calculation for Wall Mount Self Cleaning System	6
Pressure Loss Through Typical Water Pipe Chart.....	7
Minimum Pressure Requirements for Lengths of Hood	8
Self Cleaning System Overview	9
Drain Assembly	11
Electrical	12
Copper Wire Ampacity	12
OPERATION.....	13
Start Up.....	13
Special Tools Required	13
Start Up Procedure.....	13
Start Up Checklists	14
Self Cleaning Hood Start Up Checklist	15
Component Description	16
Self Cleaning Spray Bar	16
Water Manifolds.....	16
Self Cleaning Manifold	17
Self Cleaning Manifold Details	17
Self Cleaning Wash Timers.....	19
Surfactant Tank.....	20
Troubleshooting	21
Self Cleaning Hood Troubleshooting Chart.....	21
MAINTENANCE	22
General Maintenance	22
Every 6 months.....	22
Every 2 Years	22

WARRANTY

This equipment is warranted to be free from defects in materials and workmanship, under normal use and service, for a period of 12 months from date of shipment. This warranty shall not apply if:

1. The equipment is not installed by a qualified installer per the MANUFACTURER'S installation instructions shipped with the product,
2. The equipment is not installed in accordance with federal, state and local codes and regulations,
3. The equipment is misused or neglected,
4. The equipment is not operated within its published capacity,
5. The invoice is not paid within the terms of the sales agreement.

The MANUFACTURER shall not be liable for incidental and consequential losses and damages potentially attributable to malfunctioning equipment. Should any part of the equipment prove to be defective in material or workmanship within the 12-month warranty period, upon examination by the MANUFACTURER, such part will be repaired or replaced by MANUFACTURER at no charge. The BUYER shall pay all labor costs incurred in connection with such repair or replacement. Equipment shall not be returned without MANUFACTURER'S prior authorization and all returned equipment shall be shipped by the BUYER, freight prepaid to a destination determined by the MANUFACTURER.

INSTALLATION

It is imperative that this unit is installed and operated with the designed airflow and electrical supply in accordance with this manual. If there are any questions about any items, please call the service department at **1-866-784-6900** for warranty and technical support issues.

Mechanical

WARNING: APPLY THE APPROPRIATE WATER PRESSURE AND TEMPERATURE TO ALL FITTINGS TO PREVENT LEAKAGE AND COMPONENT FAILURE

System Nomenclature

System	Water Connection
W1	1 Hot Water
W2	1 Cold Water
W3	1 Hot, 1 Cold Water

ATTENTION: SYSTEM MUST BE INSTALLED IN CONDITIONED SPACE BETWEEN 32°F AND 130°F

Ensure there is 36 inches of service clearance to the front of the panel.

Plumbing Connections for Self Cleaning

Several field plumbing connections are required for proper Self Cleaning hood operation. It is recommended that all plumbing connections be sealed with Teflon tape or pipe thread sealant. Use care not to contaminate the interior surfaces of the water lines when plumbing the unit, as small particulate can clog the orifices of the spray nozzles.

1. All incoming plumbing connections are connected via 3/4" quickseals at the top of the utility cabinet. See Figures 1 and 2 for details.
2. Self Cleaning hoods with the **W1** option (Hot Water Wash) require a hot water connection at 140°F to 170°F and 30 to 50 psi operating pressure. If the operating pressure is greater than 50 psi, a water regulator must be connected. Max water static pressure is 125 psi. Typical water flow rate is 0.7 GPM per foot of hood. The spray lasts for a factory setting of 3 minutes every time the fans are switched off.
3. Self Cleaning hoods with the **W2** option (Constant Cold Water) require an unheated water connection at an operating pressure of 10 to 20 psi. If the pressure is greater than 40 psi, a water regulator must be connected. Max water static pressure is 125 psi. Typical water flow rate is 0.4 GPM per foot of hood. The spray runs constantly while the fans are turned on.
4. Self Cleaning hoods with the **W3** option (Hot Water Wash and Constant Cold Water) require a hot water connection at 140°F to 170°F and 30 to 50 psi operating pressure and an unheated water connection at 10 to 20 psi operating pressure. If the pressure is greater than the max rating, a water regulator must be connected. Max water static pressure is 125 psi. Typical water flow rate is 0.4 GPM per foot of hood for cold water and 0.7 GPM per foot of hood for hot water. The cold spray runs constantly while the fans are turned on and the hot water lasts for a factory setting of 3 minutes every time the fans are switched off.
5. If multiple hoods are arranged in an end-to-end or back-to-back arrangement, plumbing connecting the hoods must be piped in the field. The plugged end of the spray bar is used to do this. Remove the plugs on the main hood and the adjacent hood and simply pipe the two together. The highest part of the connecting pipe must not exceed the height of the vacuum breaker in the main utility cabinet. See **Figure 1A** for illustration.
6. There is also a non-pressurized 1-1/2 inch drain connection that must be piped. This allows water to drain from the hood grease trough. It must be connected to the building grease trap. 30 inch tall hoods will have 2 drains and hoods 10 feet and longer will also have 2 drains. See Figure 3 for details.
7. Once all supply and drain lines are connected, remove one of the nozzles and flush the lines.
8. The Ansul fire system duct detection bracket and fusible link are shipped loose to be installed in the exhaust ductwork. The detector must be installed no more than 20 feet from the hood, and installed per the Ansul fire system guidelines.

Warning

All field connections between hoods and drain lines must be run with Steel, Stainless Steel, or Copper pipe. Plastic pipe cannot be used for drains or field connections between hoods, as it could fail and become hazardous.

Piping Loss Calculation for Wall Mount Self Cleaning System

To ensure proper operation of the Self Cleaning System, a minimum of 30 PSI water operating pressure during spraying must be achieved at the hood nozzles. For this to occur, proper sizing of the water line is required. Use the following steps to calculate the piping minimum size.

1. Use the **Minimum Pressure Requirements for Lengths of Hood** chart and find the Self Cleaning minimum PSI required at the hood inlet. Subtract this value from the available PSI at the panel pressure gauge. Maximum panel operating pressure is 50 psi. This will be your maximum allowable pressure drop for field installed pipes between the panel and the hood.
2. Most fittings add an equivalent pipe length to the total run. Use the chart below to calculate the equivalent pipe length for installed fittings. If you have multiple fittings of one type, simply multiply the number below by the total number of the fitting and add to the total run length.

Equivalent Pipe Length For Various Pipe Fittings

Pipe Size Inches	45° Elbow	90° Elbow	Tee Thru Run	Tee Thru Branch
3/4"	1.03	2.21	1.23	4.41
1"	1.31	2.81	1.56	5.62
1 1/2"	2.15	4.31	2.4	8.63

3. To calculate the total flowing pressure drop between the panel and the hood, take the total equivalent length found in step 2 and add the total linear field installed pipe length. Multiply this number by the value found in the table below, Pressure Drop (PSI) per Equivalent Foot of Waterline. (Gallons per minute is calculated by multiplying the length of the hood by 0.7 gpm) This will be the friction pressure drop between the hood and the panel.

Pressure Drop (PSI) per Equivalent Foot of Waterline - Pipe Size

Gallons per Minute	Waterline Pipe Size (psi per foot of pipe)		
	3/4"	1"	1 1/2"
10	0.102	0.029	0.004
20	0.368	0.105	0.014
30	0.779	0.222	0.030
40	1.327	0.379	0.052
50	2.005	0.573	0.078
60	2.809	0.803	0.109
70	3.735	1.068	0.146
80	4.782	1.367	0.186
90	5.947	1.700	0.232
100	7.223	2.066	0.282

4. Add in the pressure drop due to gravity. This must be evaluated to overcome any rise in pipe elevation between the panel and the hood. There is .43 psi/ft of vertical rise of pressure drop.
5. Now, compare the maximum allowable pressure drop from step 1 to the calculated pressure drop from step 3. If the calculated pressure drop exceeds the maximum allowable pressure drop, increase the pipe size and recalculate steps 2 and 3. Continue this step until the calculated pressure drop is below the maximum allowable.

Field Pipe Pressure Drop Calculation Example:

Wall mount panel installed with 30 feet of 3/4" linear pipe between panel and hood. (2) 90 degree elbows are installed in the pipe run and the pipe run has a vertical rise of 5 feet. Length of end-to-en hood system is 32 feet.

Hood System = 32 feet. Flow rate = 32 feet * 0.7 gpm = 23 gpm
Pressure required at hood = 37 psi
Pressure at panel gauge = 50 psi
Allowable pressure drop between panel and hoods: 50 psi – 37 psi = **13 psi**

Equivalent length of pipe = 30 + 2 * 2.21 = 34.42 feet
Friction Pressure Drop through pipe = 34.42 * 0.779 = 26.81 psi
Gravitational Pressure = 0.43 psi/ft * 5 feet = 2.15 psi
Total Pressure Drop in Field Pipe between panel and hood = 26.81 psi + 2.15 psi = **28.96 psi**
Allowable pressure drop = 13 psi

This system will not work correctly because calculated pressure drop is greater then allowable pressure drop. Pipe size will need to be change to 1inch diameter.

Re-calculate with 1 inch pipe instead of 3/4" pipe:

Equivalent length of pipe = 30 + 2 * 2.81 = 35.62 feet
Friction Pressure Drop through pipe = 35.62 * 0.222 = 7.91 psi
Gravitational Pressure = 0.43 psi/ft * 5 feet = 2.15 psi
Total Pressure Drop in Field Pipe between panel and hood = 7.91psi + 2.15 psi = **10.06 psi**
Allowable pressure drop = 13 psi

This system will work correctly because calculated pressure drop is less then allowable pressure drop.

Pressure Loss Through Typical Water Pipe Chart

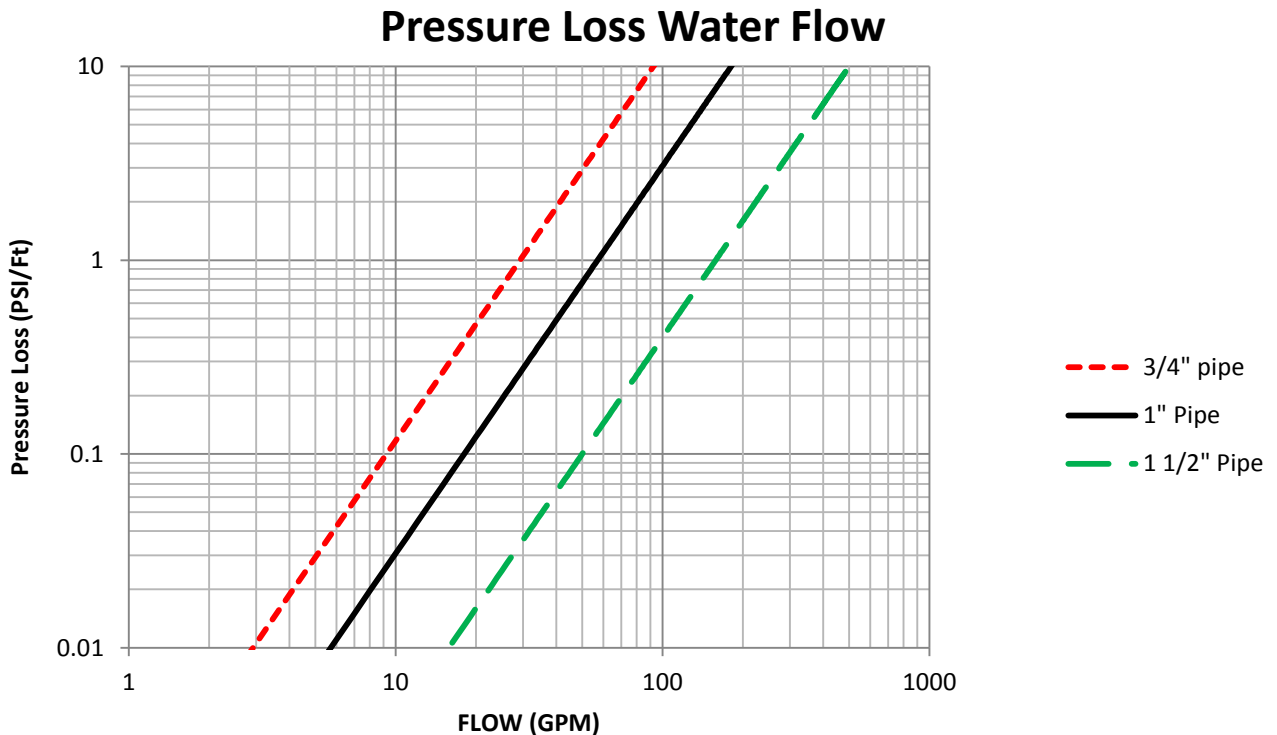

Minimum Pressure Requirements for Lengths of Hood

Length of Hood (Ft)	Minimum Inlet Water Pressure for Cold Mist (PSI)	Minimum Inlet Water Pressure for Self Cleaning (PSI)
0	10	30
4	10	30
8	10	30
12	10	30
16	15	30
20	15	31
24	15	32
28	15	34
32	20	37
36	20	39
40	20	42
44	20	46
48	20	50

Table 1

Note: Water pressure may not drop below 30 PSI while the hood hot water is operating. Pressure may not rise above 50 PSI when the hood is spraying. If the operating pressure is greater than 50 PSI, a water regulator must be connected. The chart above is for continuous hood installations. If the above length is exceeded, water line must be branched for adequate water supply.

Self Cleaning System Overview

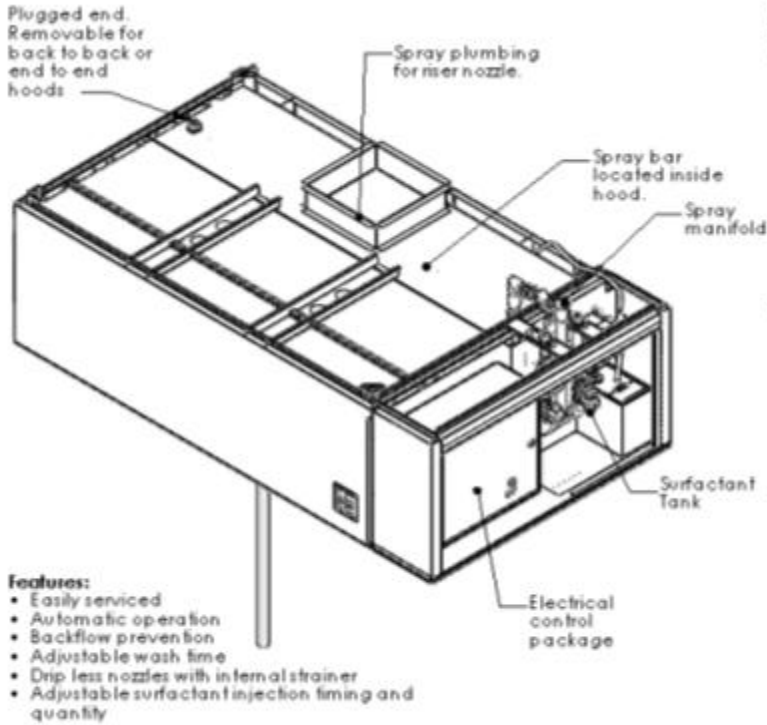

Note:
Filters must be installed for proper system operation. Filters can be removed once the system is off.

The Fully Integrated Self Cleaning System has the following options:

1. **Hot Water Fully Integrated Self Cleaning System (W1)**
The hot water fully integrated self cleaning system uses the basic manifold with the addition of a detergent pump and timer to control the system. When the fan power switch is turned off, the system sprays and injects surfactant into the plenum for cleaning. The length of the wash cycle and surfactant injection are adjustable. It is recommended that the wash time be 3 minutes and detergent injection is 1 second every 1 minute.
Water Pressure = 30 to 50 PSI Operating (120V)
Water Pressure = 125 PSI Maximum Static
Water Temp = 140° to 170° F
2. **Cold Water Fully Integrated Self Cleaning System (W2)**
The cold water fully integrated self cleaning system uses the basic manifold without a surfactant pump or timer. When the fan switch is turned on, the system begins to spray cold water into the plenum. The spray stops once the fans are turned off. Water pressure regulator is supplied by other.
Water Pressure = 10 to 20 PSI Operating
Water Pressure = 125 PSI Maximum Static
3. **Hot And Cold Fully Integrated Self Cleaning System (W3)**
The hot and cold fully integrated self cleaning system uses both systems above with one change. It has two water inlets versus the previous systems one. This system combines the functionality of the above systems.

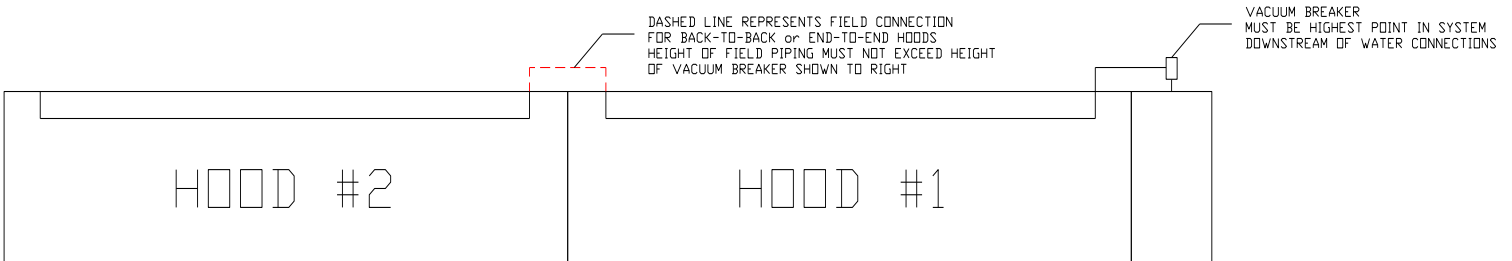
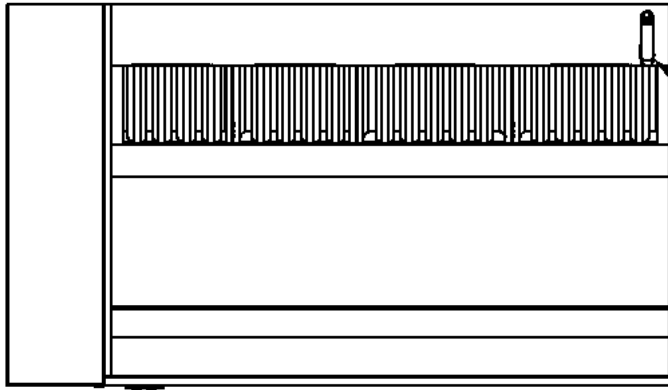

Figure 1A

Self Cleaning Hood Top and Bottom View

Bottom View of Hood



- 1 1/2" Pipe drains (Optional).
- Hoods 10' or greater in length => 2 Drains
- 30" tall hoods => 2 Drains
- All other hoods => 1 Drain. Read paperwork for placement

Top View of Hood

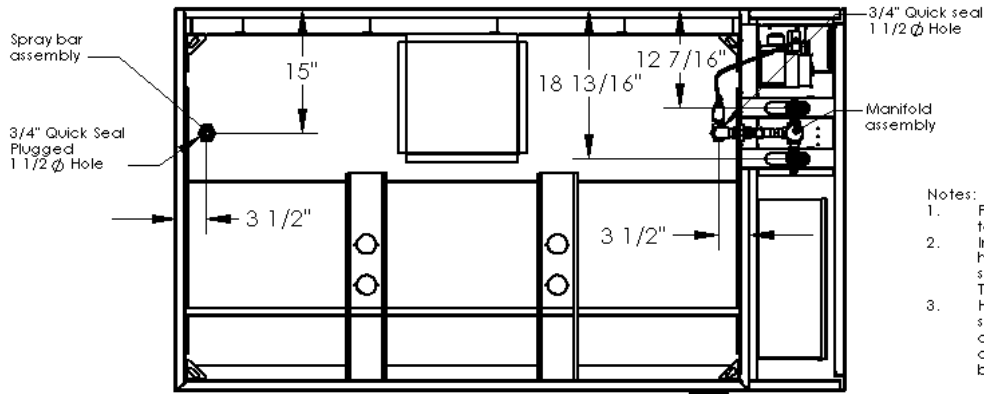

- Notes:
1. Plenum of hood must be dye penetrant tested for leaks.
 2. Instead of 1" OD grease drain, hood must have 1 1/2" NPT drains installed. Follow same rules as the standard grease drains. This will be dye penetrant tested as well.
 3. Hood lengths over 10 feet must have center supports. This support consists of a 3/4" tee, close pipe nipple, and a quick seal with a cap spaced evenly throughout the spray bar.

Figure 2

Drain Assembly

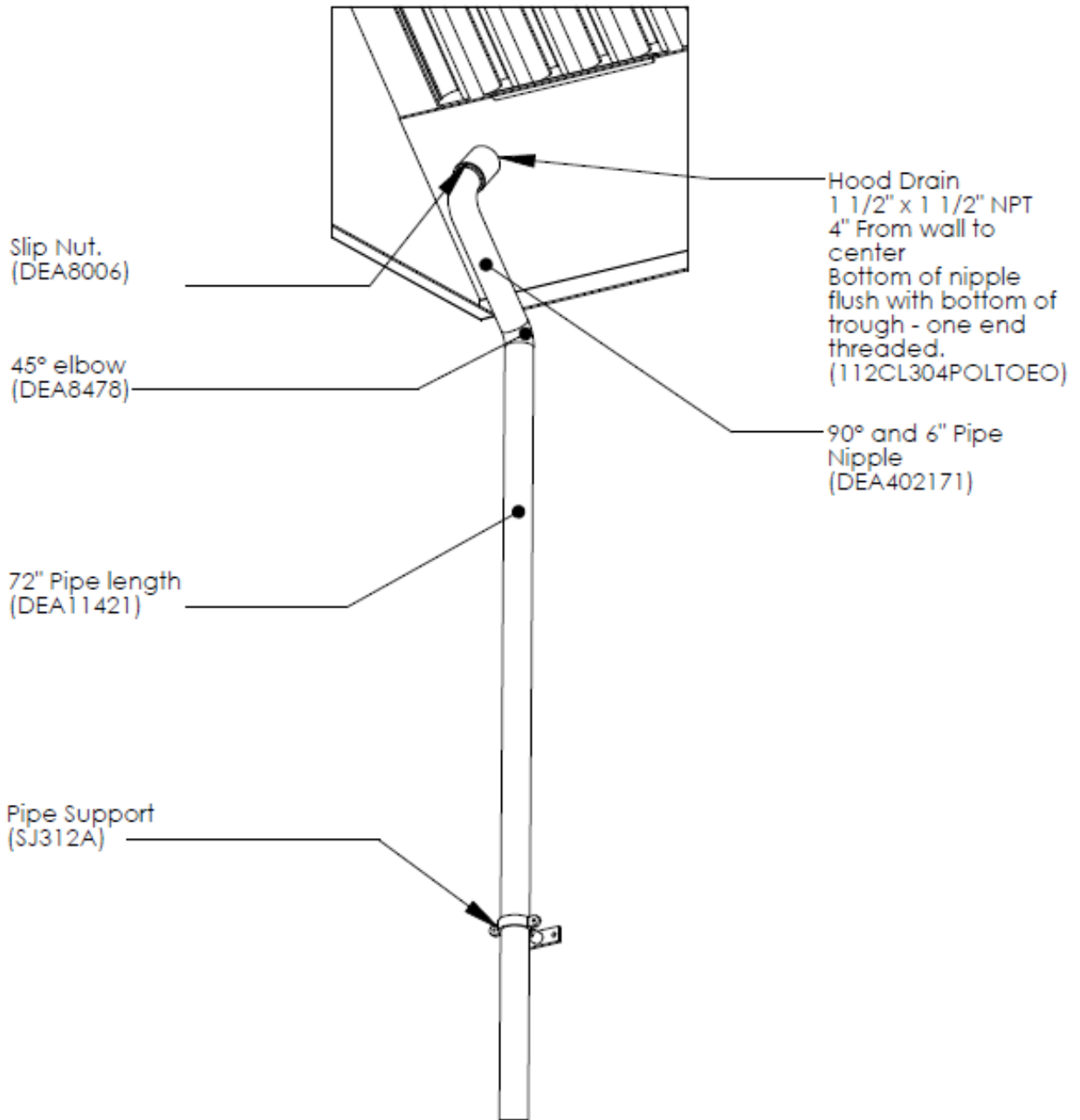

Figure 3

Electrical

Before connecting power to the control, read and understand the entire section of this document. As-built wiring diagrams are furnished with each control by the factory, and are attached either to the door of the unit or provided with the paperwork packet.

Electrical wiring and connections should be done in accordance with local ordinances and the National Electric Code, ANSI/NFPA70. Be sure the voltage and phase of the power supply and the wire amperage capacity is in accordance with the unit nameplate.

WARNING!!

Disconnect power before installing or servicing control. High voltage electrical input is needed for this equipment. A qualified electrician should perform this work.

- | Wire Size AWG | Maximum Amps |
|---------------|--------------|
| 14 | 15 |
| 12 | 20 |
| 10 | 30 |
| 8 | 50 |
| 6 | 65 |
| 4 | 85 |
1. Always **disconnect power** before working on or near this equipment. Lock and tag the disconnect switch or breaker to prevent accidental power up.
 2. **There are multiple electrical connections** required for this control. **120VAC** should be wired to terminals **H1** and **N1**. If the hood is equipped with a separate light circuit, 120VAC should power it per the as-built schematic. Fan wiring connections should be made per the schematic. H1 and N1 should not be connected to a shunt trip breaker.
 3. Make certain that the power source is compatible with the requirements of your equipment. The system wiring schematic identifies the **proper phase and voltage** of the equipment.
 4. Before connecting control to power source, verify power line wiring is de-energized.
 5. Secure the power cable to prevent contact with sharp objects.
 6. Do not kink power cable and never allow the cable to come in contact with oil, grease, hot surfaces or chemicals.
 7. The hood lights wiring will also need to be wired to terminals "B" and "W". Verify connections on wiring schematic.
 8. Before powering up the system, make sure that the interior of the control is free of loose debris or shipping materials.
 9. **If 3 phase motors are spinning in the incorrect direction, switch any two wires on the output of the motor starter. Rewire single phase motors per the motor schematic to *change direction*.**
 10. If any of the original internal wire supplied with the system must be replaced, it must be replaced with type THHN wire or equivalent.

OPERATION

Prior to starting up or operating the system, check all fasteners for tightness. Ensure that the wiring is installed properly and that all nozzles and panels are installed.

The Self Cleaning hood is designed to use hot water to wash the hood plenum and immediate duct section every time the fan switch is switched from the “ON” position on the main control panel. When the switching action occurs, hot water sprays along the entire length of the hood and towards the back of the hood for a factory setting of 3 minutes. During this time, surfactant is injected into the water stream for a duration of 1 second for each minute of wash time. Once the wash cycle is complete, water stops spraying and the hood filters are to be removed and cleaned.

If the hood is ordered with a cold water mist option, cold water sprays continuously during the cooking process. Cold water stops spraying when the fan switch is switched from the “ON” position.

Start Up

Special Tools Required

- AC Voltage Meter
- Standard Hand Tools
- Hand-held Propane Torch
- Surfactant (Part Number WWDETER for 4 Gallons, WWDETER-1G for 1 Gallon)

Start Up Procedure

1. Check all nozzles to make sure they are installed and tight.
2. Install all hood filters per the filter installation configuration chart below. There are drip blanks secured to the filters to prevent water from exiting the hood between the filters.
3. Open all water valves to the hood.
4. Fill surfactant tank with surfactant. The “Add Surfactant” light should not be on. Prime the surfactant pump with the push-button on the face of the electrical control package.
5. There are 2 timers that control the spray and the surfactant injection. The wash timer is set to 3 minutes from the factory. The surfactant timer is factory set for 1 second of injection during each minute of wash time. The injection occurs at the start of each minute. The timer settings should be verified. (See section “Self Cleaning Timers for information)
6. Turn the hood fan switch to the “ON” position. Fans should operate. If they do not, check wiring. If the hood has the cold water mist option, cold water should begin to spray.
7. To operate the wash cycle, simply turn the fan switch off. The wash cycle energizes automatically and will remain on for the duration of the wash timer setting.
8. Verify that surfactant is being injected properly into the water stream.
9. Verify the pressure and temperature of the water via the pressure/temperature gauge. See Figure 4 for a picture of the gauge. Self Cleaning pressure should be between 30 and 50 PSI operating pressure, and Cold Mist operating pressure should be between 10 and 20 PSI.
10. Check all manifold pipe connections to ensure there are no water leaks.
11. Check all filters to make sure that no water is leaking back through the filters.
12. Verify that the hood grease trough is draining properly and there are no clogs in the drain.



Figure 4

Filter Installation Configuration

The hood filters have drip blanks attached to them to prevent water leakage through the filters. The chart below shows the location of the drip blanks and the last filter to be installed into the hood. See Figure 5 below for details.

*NOTE: BLUE FILTERS DESIGNATE THE LAST FILTER THAT IS INSTALLED IN THE HOOD.

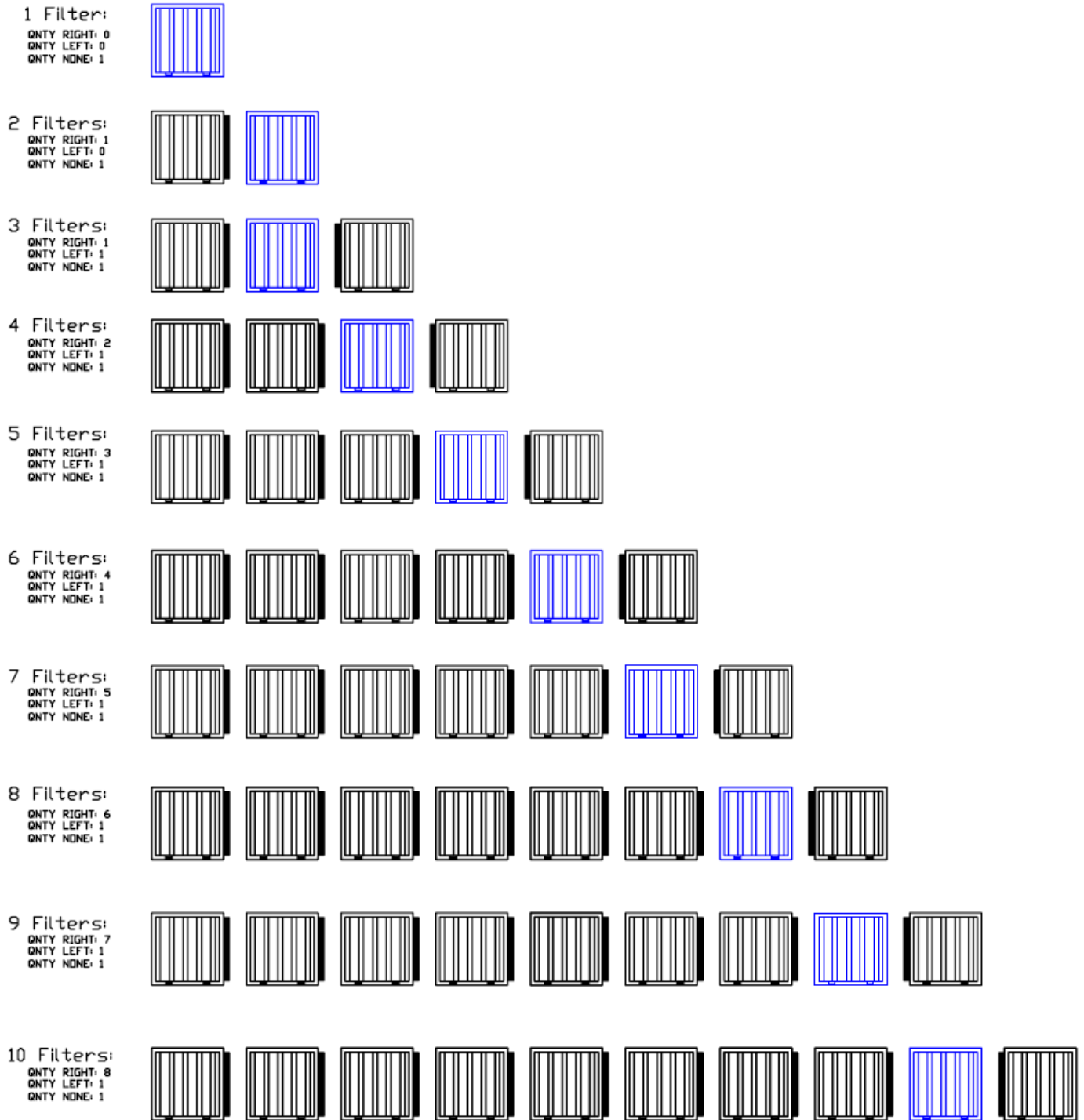

Figure 5

Start Up Checklists

Self Cleaning Hood Start Up Checklist

Action	Completed (Yes/No)	Result
Check All Nozzles for Tightness		
Open all Valves to Hood		
Fill Surfactant Tank		
Prime Surfactant Pump		
Set All Timers		
Check Fan Operation		
Operate Wash Cycle		
Verify Surfactant Pump Operation		
Verify Operating Hot Water Pressure (30-50 PSI)		
Verify Operating Cold Water Pressure (10-20 PSI)		
Verify Max Water Static Pressure (125 PSI)		
Verify Hot Water Temperature		
Check For Leaks in Manifold		
Check For Leaks through Filters		
Verify that Water is Draining Properly		

Component Description

The following section lists the major controls and components used in the Self Cleaning hood.

Self Cleaning Spray Bar

The Self Cleaning hood contains a spray bar that extends the entire length of the hood immediately behind the filters in the hood. The bar is $\frac{3}{4}$ " brass fittings with nozzles that spray directly toward the back of the hood. The same spray bar is used in hot water wash and cold water mist. Water enters the spray bar via a $\frac{3}{4}$ " quickseal. The other end of the spray bar is plugged. If hoods are installed back-to-back or end-to-end, the plugged end of the spray bar can be un-plugged and connected to the next spray bar. See Figure 6 below for details.

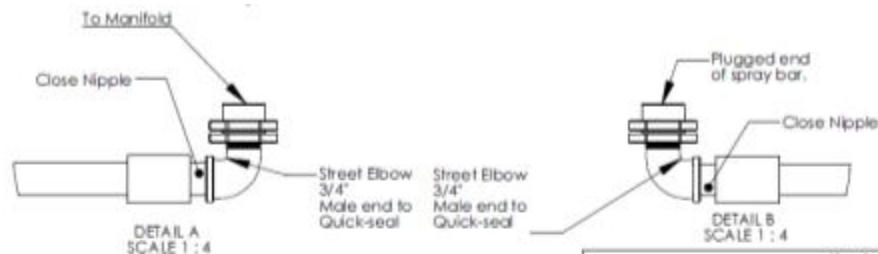

Notes:

1. All fittings and pipe will be Brass.
2. Sections of pipe and tees can be pre-assembled for use. The majority of the length will use these parts.
3. Ends will be made using a Street elbow inside a quick-seal. See Detail A and B.
4. The Variable length section of pipe will be used to complete the spray assembly.
5. On hoods 10' and longer, a tee will be installed at the center of the spray bar for support. This will be a $\frac{3}{4}$ " Tee with a plugged quick-seal. If this interferes with riser, move supports to both sides of riser.
6. Riser plumbing will be $\frac{1}{4}$ " NPT Brass. The placement of the elbow is dependant on the riser location. The nozzle needs to be centered, both vertically and horizontally, within the riser. Riser nozzle must follow table to right.
7. When riser nozzle is located directly under center of riser on spray bar, main elbow must point upwards.

Nozzles for Hot Water Wash (W1)			
Description	Part Number	Macola	Flow Rate
Riser Nozzle	1/4TT+TH-4.3W	2591	.70 GPM @ 30 PSI
Spray Bar Nozzle	1/4TT+TH-4.3W and 4193A-5-50-55	2591 and 2592	.70 GPM @ 30 PSI
Nozzles for Cold Water Mist (W2) and Hot Water Wash with Cold Water Mist (W3)			
Description	Part Number	Macola	Flow Rate
Riser Nozzle	Nozzle Location must be Plugged		
Spray Bar Nozzle	1/4TT+TH-4.3W and 4193A-5-50-55	2591 and 2592	.40 GPM @ 10 PSI

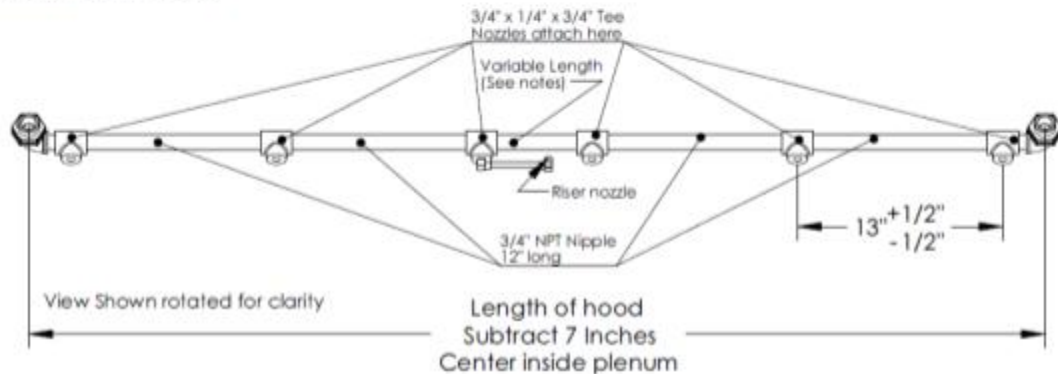

Figure 6

Water Manifolds

There are several versions of manifold configurations. The Self Cleaning with hot water wash (W1) has one hot water connection. The cold water mist (W2) has one cold water connection. The hot water wash with cold water mist (W3) has one hot water and one cold water connection.

Self Cleaning Manifold

SELF CLEANING UC INSTALLATION

Notes:

1. All fittings and pipe will be Brass. Except for drain components.
2. All wiring must be located inside liquid tight conduit.

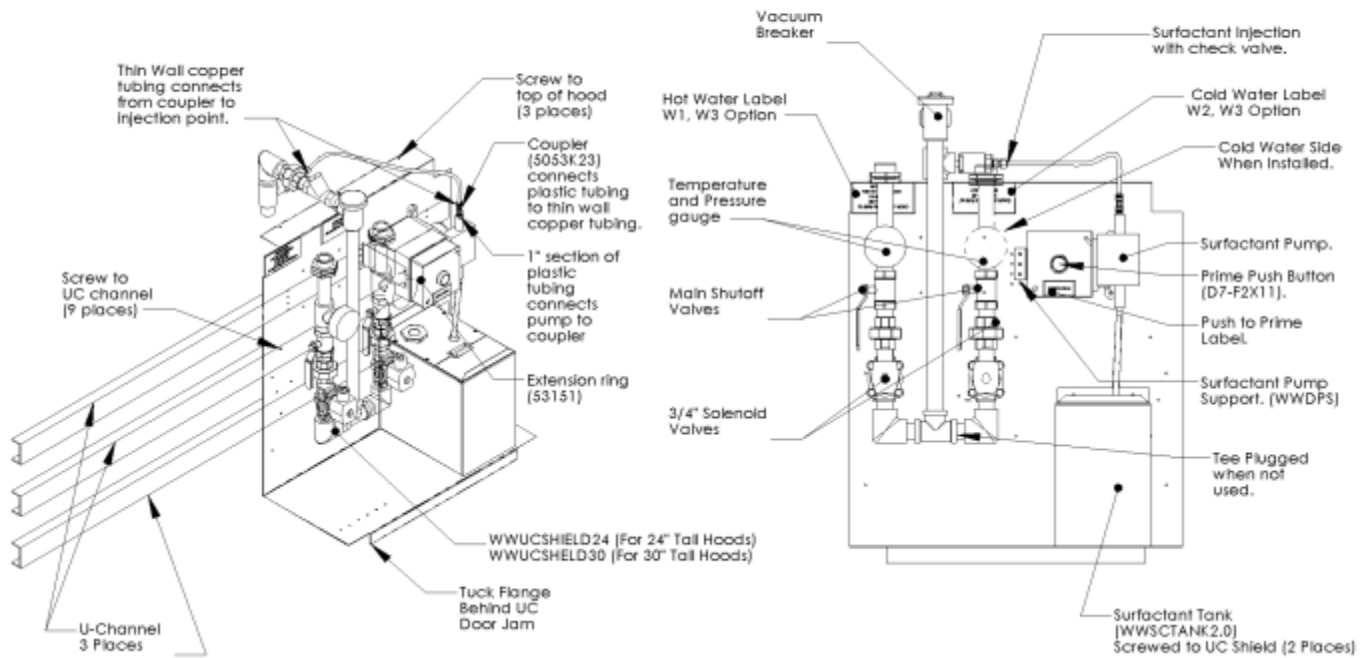
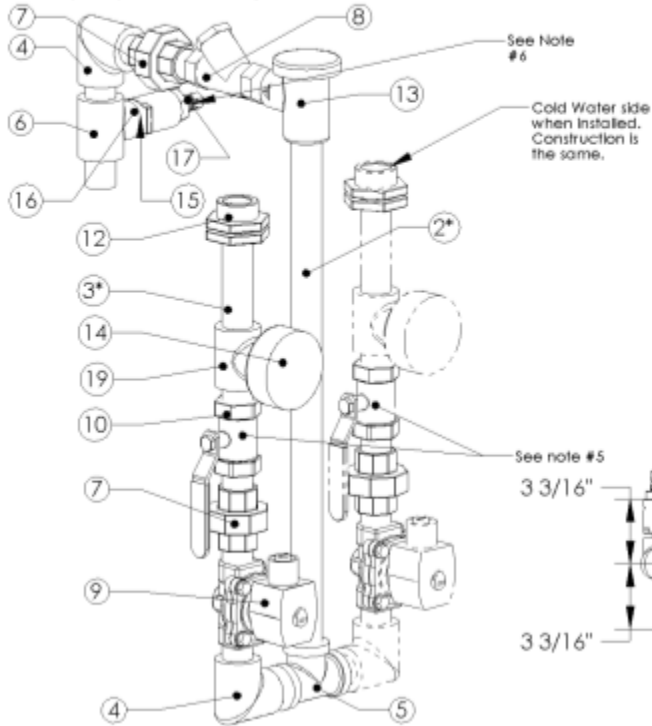

Figure 7

Self Cleaning Manifold Details

Notes:

1. All fittings and pipe will be Brass, except for drain components.
2. Length and width of manifold must match measurements listed on this page.
3. All pipe nipples are close unless otherwise noted.
4. For 30" tall hoods, plumbing must be lengthened in three places by 6". This is noted below with an *.
5. Valves can be rotated for best fit inside cabinet
6. Thin wall copper tubing to be run to the coupling near the pump to #17. 1" of plastic tubing is used between coupler and pump.
7. Do not use Pipe Dope on union mating surfaces as this can cause leaks.



Manifold Parts				
#	Description	Part #	Macole #	Quantity Used
1	3/4" Close Brass Nipple	458K191	458K191	15
2	3/4" x 1/2" Brass Nipple	4512K19	4512K19	1
3	3/4" x 4 1/2" Brass Nipple	458K335	458K335	2
4	3/4" Brass Elbow	4429K164	4429K164	3
5	3/4" Brass Tee	4429K254	4429K254	1
6	3/4" x 1/4" x 3/4" Brass Tee	4429K229	4429K229	1
7	3/4" Brass Union	4429K215	4429K215	3
8	3/4" Brass Wye Strainer	4393K24	4393K24	1
9	3/4" Brass Solenoid Valve	82100005 120/60, 110/60	AG3005	2
10	3/4" Manual Ball Valve	4786K24	4786K24	2
11	3/4" Plug	50786K256	50786K256	1
12	3/4" Quick Seal	372	372	2
13	3/4" Vacuum Breaker	288A	AQ2584	1
14	Temperature and Pressure gage	AQ2516	AQ2516	2
15	1/4" Close Brass Nipple	458K131	458K131	1
16	1/4" Check Valve	47715K21	47715K21	1
17	1/4" to Copper tubing adapter	8225K66	8225K66	1
	1/4" Thin Wall Copper tubing			
	1/4" Tube Coupler	8053K23	8053K23	1
18	Solenoid Connection Cable 120V	5,646-551-L50A	A0017121	2
19	3/4" x 1/2" x 3/4" Brass Tee	BRF20810	A0007789	2
Not Shown	Self Cleaning Manual	A0019144	A0019144	1

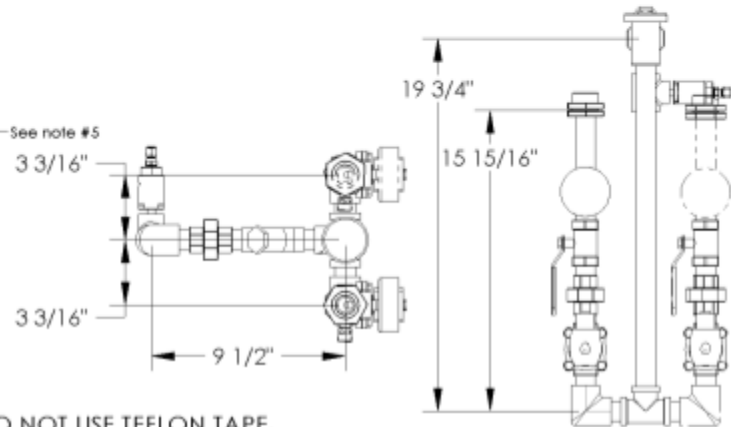

Note: Pipe Dope Must Be Used To Seal Threads. DO NOT USE TEFLON TAPE.

Figure 8

Self Cleaning Wash Timers

The Self Cleaning option includes two timers that ship in the main control panel. These timers control the wash cycle length and the surfactant injection.

The timer shown to the right is the wash cycle timer. The wash cycle timer is a fleeting off timer and is triggered by turning the fan switch to the "OFF" position. The time is factory set to 3 minutes but is adjustable on an application specific basis. It has a range of .5 to 10 minutes and is adjusted by simply rotating the large red dial.

The time shown on the right is the surfactant injection timer. The surfactant timer is an asynchronous on-off timer. This means that it cycles contacts on and off for adjustable time ranges. The timer is factory set to inject surfactant for 1 second and every minute. The interval time (time when not injecting) is set by the top two dials. The small top dial on the timer allows main unit adjustments. This dial can be set to 1, 3, 10, or 60 seconds (s), minutes (m), or hours (h). Once the small top dial is set, the top, large red dial adjusts the percentage of the middle dial. For example, if the small top dial is set to 1 minute, and the large red dial is set to 1.0, the selected time period would result in 1 (1 minute * 1.0 = 1 minute) minute. The large dial is a percentage of the small dial.

The surfactant injection time is set by the bottom two dials. The small bottom dial on the timer allows main unit adjustments. This dial can be set to 1, 3, 10, or 60 seconds (s), minutes (m), or hours (h). Once the small bottom dial is set, the bottom, large red dial adjusts the percentage of the middle dial. For example, if the small bottom dial is set to 1 second and the large red dial is set to 1.0, the selected time period would result in 1 (1 second * 1.0 = 1 second) second. The large dial is a percentage of the small dial.

The red switch on the right side of the face of the timer should not be adjusted and is factory set to the bottom position (beginning of time period). **The pictures shown illustrate the factory settings of the timers.**



Surfactant Tank

The surfactant tank contains a liquid level control which energizes when the tank is completely empty. In the event that the low level sensor is activated, an "Add Surfactant" light will illuminate on the control panel. To reset light, simply fill the surfactant tank with surfactant. Figure 9 below shows tank details.

NOTE: SC-5 surfactant from 20/10 Products Incorporated must be used.

SURFACTANT TANK

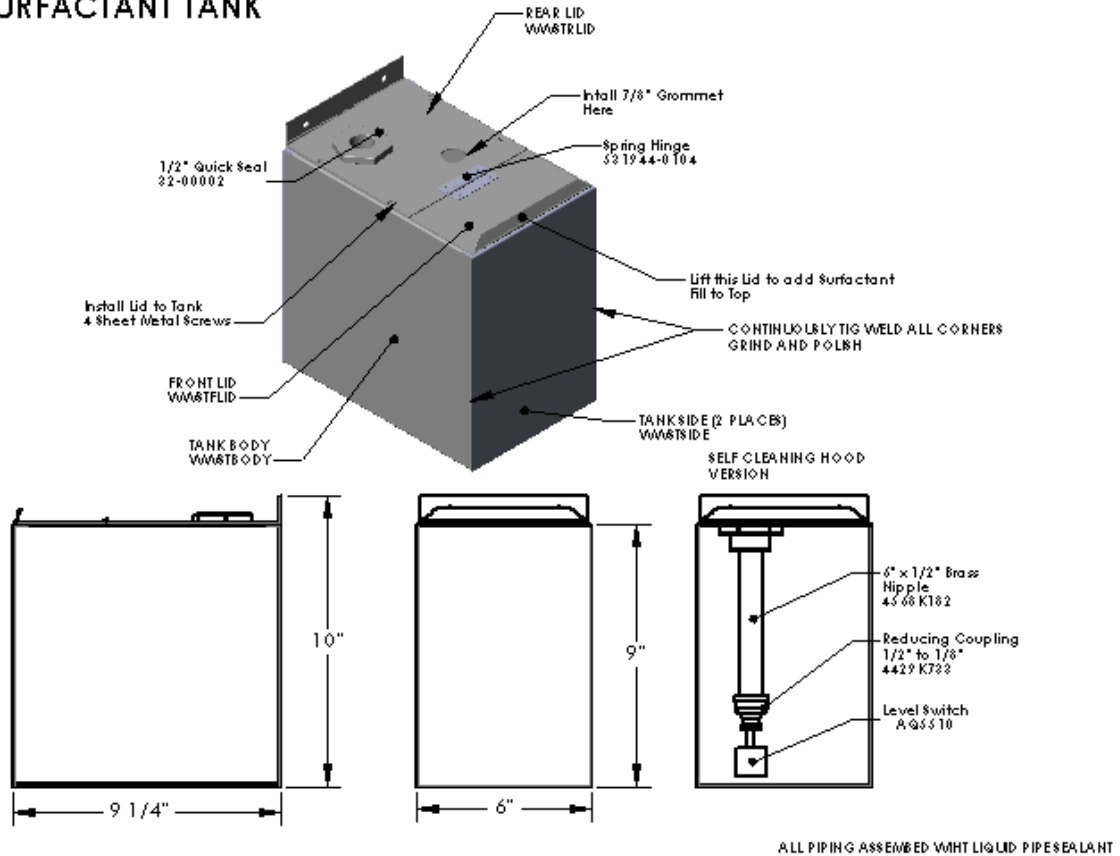

Figure 9

Troubleshooting

The following table lists causes and corrective actions for possible problems with Self Cleaning hoods. Review this list prior to consulting manufacturer.

Self Cleaning Hood Troubleshooting Chart

Problem	Potential Cause	Corrective Action
Plenum not being cleaned	No Water Pressure	Verify Hot Water Pressure >30 PSI Open Manual Valve if closed
	Clogged nozzles	Clean or replace nozzles or strainer
	Timer Settings improperly set	Wash timer should be set for approximately 3 minutes
	No water pressure	Turn main building water valve on
	Nozzle spray pattern incorrect	Nozzles must be pointed toward back of plenum
	No Surfactant	Add Surfactant
Leaking Manifold Pipes	Pipes not tight or sealed	Reseal and tighten pipes
Water Leaking from Vacuum Breaker	Riser nozzle installed too high	Verify that vacuum breaker is installed higher than all downstream piping components
Add Surfactant Light On	Low Surfactant Level	Add Surfactant
Water leaks out of Filters	Filters have gaps between them	Add Filter Drip Blanks or reorient filters
Water Overflows Grease Trough	Clogged Drain	Clean Drain or grease trap
	Wrong Filters Installed	Install Proper Filters per Manufacturer
	Water Pressure Too High	Water Pressure should be 70 PSI max
	Wash Timer Set Too Long	Reduce Wash Time
	Nozzles are Loose	Tighten Nozzles
	Filters are Clogged with Grease	Clean Filters

MAINTENANCE

To guarantee trouble free operation of this system, the manufacturer suggests following these guidelines. Most problems associated with unit failures are directly related to poor service and maintenance. Record any maintenance or service performed on this equipment in the documentation section located at the end of this manual.

General Maintenance

1. Hood filters must be maintained on a daily basis to ensure proper airflow and grease extraction.
2. All water connections must be verified for tightness and leak-free operation.
3. The "Add Surfactant" indicating light will illuminate when the surfactant tank is empty. Surfactant must be added immediately to guarantee proper cleaning of the hood plenum and duct connection. .

Every 6 months

1. Clean all duct sensors in hood duct connections (if equipped).
2. Check all nozzles for proper and evenly distributed water flow. If nozzles are clogged, clean or replace.
3. Check drain(s) on hood to verify there is no blockage. Improper drainage could cause hood leaks or water to back up into trough and overflow onto appliances.
4. Inspect hood plenum and wipe down any areas not being cleaned by the self-cleaning system. There may be an area where the water spray does not directly contact the metal.
5. Inspect the surfactant pump for proper operation and ensure liquid level sensor in surfactant tank is operational. Test by manually lowering the sensor to see if the "Add Surfactant" light illuminates.
6. All nozzle strainers should be removed and cleaned. Nozzles must be re-installed tightly.
7. Fill surfactant tank with surfactant.
8. The main line strainer in the manifold must be cleaned.
9. Verify that system has proper water pressure and temperature per the labels on the unit.

Every 2 Years

1. Inspect condition of all wires and plumbing. Plumbing should be free of corrosion and wire insulation must be in good condition.

START-UP AND MEASUREMENTS SHOULD BE PERFORMED AFTER THE SYSTEM HAS BEEN INSTALLED (Warranty will be void without completion of this form)

Job Information

Job Name		Service Company	
Address		Address	
City		City	
State		State	
Zip		Zip	
Phone Number		Phone Number	
Fax Number		Fax Number	
Contact		Contact	
Purchase Date		Start-Up Date	

Self Cleaning Hood Information

Refer to the start-up procedure in this manual to complete this section.

Name Plate and Unit Information		Field Measured Information	
Hood Model Number		Input Voltage	
Serial Number		Check All Nozzles for Tightness	
Volts		Open all Valves to Hood	
Hertz		Fill Surfactant Tank	
Phase		Set All Timers	
		Check Fan Operation	
		Operate Wash Cycle	
		Verify Surfactant Pump Operation	
		Verify Operating Hot Water Pressure (30-50 PSI)	
		Verify Operating Cold Water Pressure (10-20 PSI)	
		Verify Max Water Static Pressure (125 PSI)	
		Verify Water Temperature	
		Check For Leaks in Manifold	
		Check For Leaks through Filters	
		Verify that Water is Draining Properly	

