

## INSTALLATION INFORMATION

### ⚠ WARNING ⚠

Read these instructions carefully before attempting to install, operate or service this switch.

Failure to observe safety information and comply with instructions could result in personal injury, death and/or property damage.

To avoid electrical shock or damage to equipment, disconnect power before installing or servicing.

To avoid potential fire and/or explosion, do not use in potentially flammable or explosive atmosphere.

Retain these instructions for future reference. You must review your application and national and local codes to ensure that your installation will be functional and safe.

### GENERAL INFORMATION

You are installing one of the finest gas pressure switches of its type on the market. Design of these switches is based on the same principles of sensitivity, accuracy and dependability that have made Antunes Controls Air Flow Switches so successful. These switches are fully approved. They are UL listed and recognized for the U.S. and Canada, and approved by Factory Mutual (FM).

Antunes Controls Gas Pressure Switches monitor gas pressure. The models are available in high pressure and low pressure single gas switches and also in a double Hi-Lo combination switch. Pressure range varies from 1" of water column to 50" of water column.

The combination switch provides both high pressure and low pressure units in one switch. This saves wiring and installation space over an interlock system with separate high pressure and low pressure switches.

Each switch is adjustable within its range, as shown on the range scale located on front of the unit. The latch position in the reset models, and the lever indicator position in the recycle models, show whether the switch is on or off.

The Model A is sturdy, compact and cost effective. All components are well made. The switch is neat in appearance with a durable die cast aluminum electrical housing. In every way you will be pleased with the ease of installation and the reliability of Antunes Controls Gas Pressure Switches.

Please read these instructions carefully to ensure correct installation. This equipment must be installed by a licensed electrician who is experienced with combustion safeguard control systems and understands the functions of interlocking switches such as air and gas pressure switches. Prior to being put into operation with combustion safeguard systems, all switches should be tested for proper range setting and wiring. Check piping connections and switch housing for leaks with a soap bubble test. All exhaust fans and blowers should be inspected and checked for proper rotation prior to start up. If you have any problems or questions, phone or write to Antunes Controls at the numbers listed on the back page of this instruction sheet.

### ELECTRICAL

#### Ratings - All Models

10A, 1/8 HP, 125 VAC

5A, 1/4 HP, 250 VAC

Pilot Duty - 125 VA, 125-250 VAC

#### Electrical Wiring

Figure 1

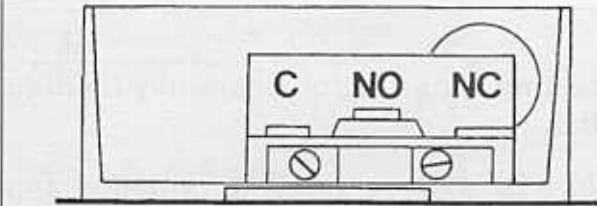
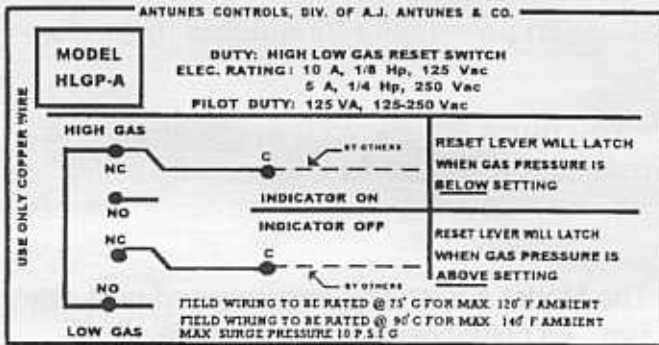
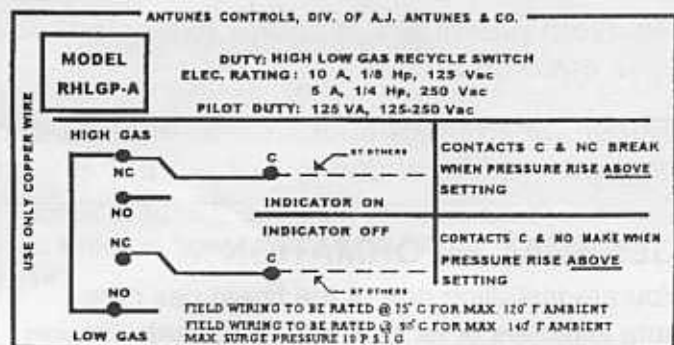

Figure 2

#### Combination Models



Reset Model HLGP-A



Reset Model RHLGP-A

#### Single Models

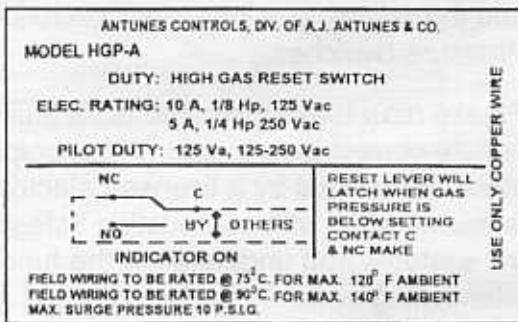

Reset Model HGP-A

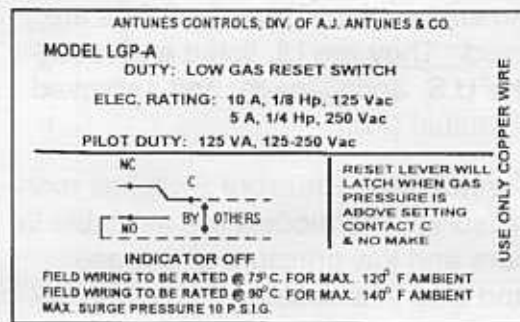

Reset Model LGP-A

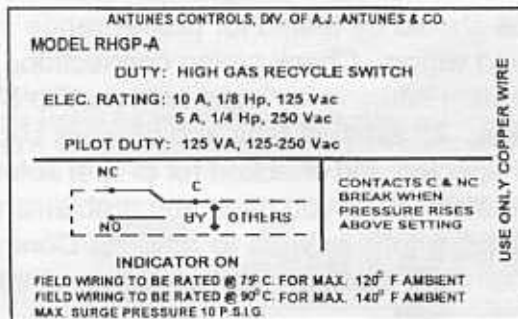

Recycle Model RHGP-A

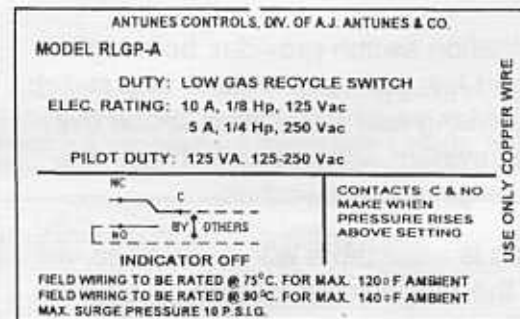

Recycle Model RLGP-A

### MOUNTING

All switches should be mounted in a horizontal position with the inlet stem down. Switches should be reasonably level but do not require accurate levelling.

Single gas switch models have a 1/4" NPT gas inlet on the standard base.

Double combination Hi-Lo switches have a 3/8" NPT inlet for high pressure and a 1/8" NPT inlet for low pressure.

Gas vent outlets are 1/8" NPT on all models.

Piping can be either standard black pipe or aluminum tubing.

All switches can be supported by the inlet pipe, but optional mounting brackets are available (Figure 3)

Switches have been factory calibrated and tested for leaks. However, it is recommended that switch, gas pipe inlets and connections be soap bubble tested for leaks after installation.

### OPERATION

#### Reset Models - Low Gas Pressure

Low gas pressure switches break the electrical circuit on pressure drop at the point when gas pressure becomes lower than the indicated set pressure.

Before the manual reset latch can be properly latched, gas pressure in the chamber must be higher than the indicated setting. The position of the reset latch on the top cover of the switch shows whether reset latch is in the ON or OFF position (Figure 4). Reset latch must be in ON position after latching to be properly set.

#### Reset Models - High Gas Pressure

High gas pressure switches break the electrical circuit when pressure rises above the indicated preset pressure. The reset latch should be latched in the ON position if the gas pressure in the switch chamber is below the indicated high setting.

#### Recycle Models - High and Low Gas Pressure Models

Recycle models operate automatically and do not need to be reset. Otherwise they are constructed, adjusted and operated in the same manner as the reset models.

#### Combination Models

Combination models contain one high pressure unit

**Figure 3** Single Model Mounting Bracket: Plated steel bracket fastens to switch housing with a 5/16-18 x 1/2" bolt (supplied with bracket).

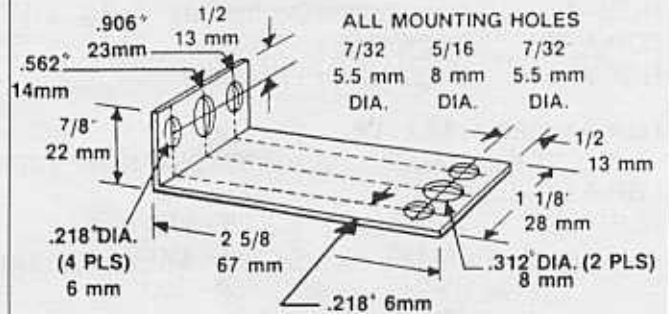

**Double Model Mounting Bracket:** Plated steel bracket fastens to switch housing with two 1/4-20 x 1/4" screws (supplied with bracket).

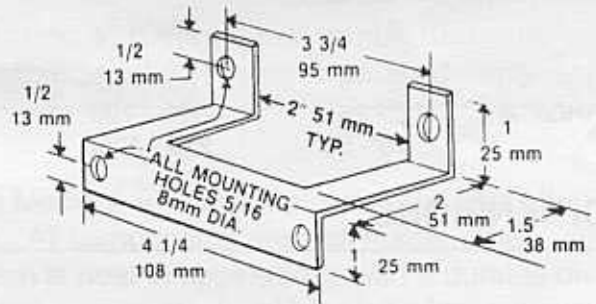

**Figure 4**

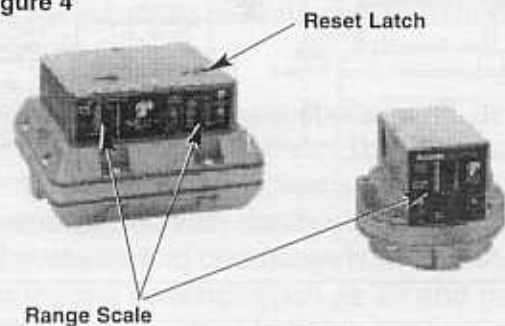

and one low pressure unit, in the range you select. Double combination switches can include any HI and LO pressure range shown under *Specifications*. (page 4).

#### Range Adjustment - All Models

To adjust gas pressure cut-off setting on either high or low pressure units, remove the electrical junction box cover and adjust indicator up or down to desired setting as shown on the range scale on front of switch (Figure 4). Turn adjusting screw clockwise to lower the setpoint or counterclockwise to raise the setpoint. Be sure to replace junction box cover after adjustment to prevent tampering.

### SPECIFICATIONS

#### Models

##### RESET

HLGP-A	Combination Double Unit
LGP-A	Single Unit, Lo-Pressure
HGP-A	Single Unit, Hi-Pressure

##### RECYCLE

RLHGP-A	Combination Double Unit
RLGP-A	Single Unit, Lo-Pressure
RHGP-A	Single Unit, Hi-Pressure

#### LOW RANGES AVAILABLE

	W.C.	MM/W.C.
LGP-A or	1" - 6"	25 - 150
RLGPA	1" - 35"	25 - 875
	2" - 14"	50 - 350
	6" - 24"	150 - 600
	10" - 50"	250 - 1250
	2" - 20"	50 - 500

#### HIGH RANGES AVAILABLE

	W.C.	MM/W.C.
HGP-A or	2" - 16"	50 - 400
RHGP-A	5" - 28"	125 - 700
	10" - 50"	250 - 1250

Maximum Surge Pressure: 10 PSIG

Maximum Ambient Operating Temperature  
140° F or 60° C

Minimum Ambient Operating Temperature  
-40° F or -40° C

#### To Order (Examples shown below):

If you want a switch with a low pressure cut-off at 4 inches, reset type - order Model LPG-A 1-6".

If you want a combination switch with a high pressure cut-off at 40" w.c. and a low pressure cut-off at 8" w.c. in a recycle type - order Model RHLGP-A 10-50", 2-14".

### DIMENSIONS

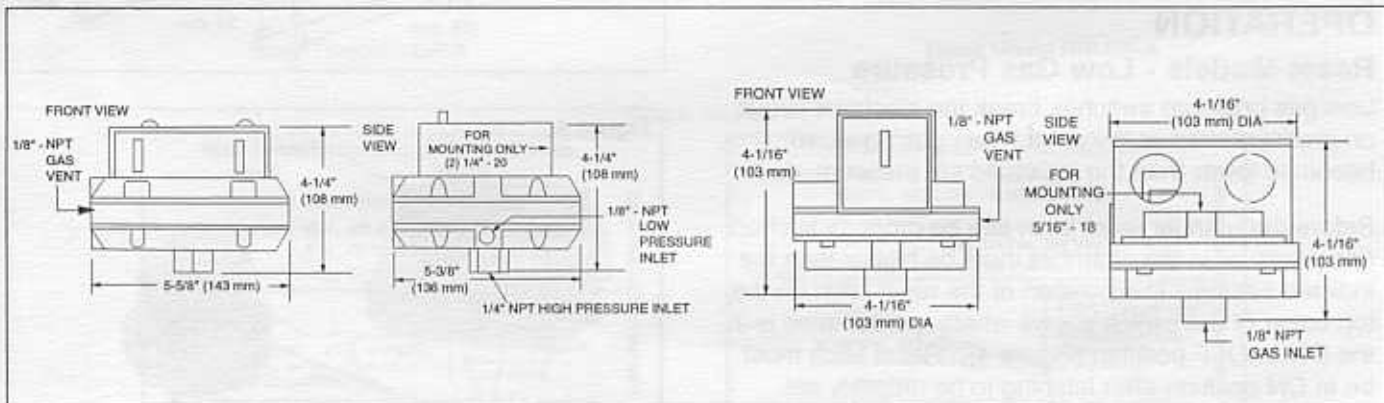

**Limitation of Liability.** If it is understood and agreed that seller's liability whether in contract, in tort, under any warranty, in negligence or otherwise, shall not exceed the return of the amount of the purchase price paid by purchaser and under no circumstances shall seller be liable for special, indirect or consequential damages. The price stated for the equipment is a consideration in limiting seller's liability. No action, regardless of form, arising out of the transactions may be brought by purchaser more than one year after the cause of action has accrued.

# ANTUNES CONTROLS

DIVISION OF A.J. ANTUNES & CO.

180 KEHOE BLVD. • CAROL STREAM, IL 60188 USA • 1-800-253-2991  
www.antunescontrols.com

TEMPERATURE CONTROLLERS • TEMPERATURE DISPLAYS • AIR PRESSURE SWITCHES • GAS SWITCHES • CUSTOM ELECTRONIC CONTROLS  
SUBSYSTEMS ENGINEERING AND MANUFACTURING • TIMERS