



# FIREYE M4RT1

## FLAME SAFEGUARD CONTROLS



**WARNING:** Selection of this control for a particular application should be made by a competent professional, licensed by a state or other government agency. Inappropriate application of this product could result in an unsafe condition hazardous to life and property.

### DESCRIPTION

The Fireye® M4RT1 Flame Safeguard Control is a compact burner management system. It is designed to provide automatic ignition and continuous flame monitoring for commercial sizes of heating and process burners that use gaseous fuels.

Flame monitoring is accomplished by a Flame Rod detector, the built in amplifier and programmer. Control functions and timing are factory set with onboard jumpers. Functions such as recycle/non-recycle, purge timing, and pilot trial for ignition (P.T.F.I.) time are determined by the jumpers. Flame Failure Response Time (F.F.R.T.) is fixed at three seconds. LED indicator lights indicate the operating status of the control.

In the event of ignition failure, or following a safety shutdown, the unit locks out, activating an alarm circuit. Cycling the power OFF and back on will reset the control. A manual reset option can be special ordered. Remote reset (via remote pushbutton) is also available as a special order option. A detailed description of the programmer sequence is found later in this document. Test jacks are provided to permit flame signal measurement during operation.

The M4RT1 control incorporates a safety checking circuit that is operative on each start. If flame (real or simulated) is detected prior to a start or during the purge, the fuel valves will not be energized, and the unit will lock out.

All M4RT1 controls do not require a wiring base due to the terminals included on the relay board. See **INSTALLATION OF CONTROL, SCANNERS, AND FLAME DETECTORS** (page 2) for temperature and wiring requirements.



## SPECIFICATIONS

**Supply:**

120V (min. 102, max. 132) 50/60 Hz

**Table 1: AMBIENT TEMPERATURE LIMITS**

	MAXIMUM		MINIMUM	
Control	140°F	(60°C)	- 40°F	(- 40°C)
Flame Rod (Tip 2460 F)	1500°F	(816°C)	- 40°F	(- 40°C)

**Power Consumption:** 12 VA (Operating)

**Shipping Weight (Approx.):** 2.2 lbs. (1.4kg)

**Table 2: LOAD RATINGS**

Fireye Terminal	Typical Load	Maximum Rating & 120V 60 Hz
3 or 4 Individual or combined	Pilot valve(s) Solenoid valve Ignition Transformer	125 VA pilot duty (solenoid valve) plus 250 VA (Transformer)
5	Main Fuel Valve(s)	125 VA pilot duty (solenoid) or 25 VA pilot duty (solenoid) and 400 VA (opening) motorized
8	Motor or contactor	Motor normally energized and de-energized by the operating control whose rating must be suitable. Terminal 8 rated to de-energize 9.8 FLA, 58.8 LRA, on safety lockout.
A	Alarm	50 VA, pilot duty
Minimum load requirement = 100mA		

## APPROVALS

**Underwriters Laboratories Inc.**

Recognized Components Guide MCCZ2

File MP1537

## ORDERING INFORMATION

**CONTROL:**

M4RT1 120 VAC (min.102, max 132) Supply, 50 Hz/60 Hz.

**FLAME DETECTORS:**

69ND1-1000K4 12 inch flame rod, 1/2" NPT connector

69ND1 -1000K6 18 inch flame rod, 1/2" NPT connector

69ND1-1000K8 24 inch flame rod, 1/2" NPT connector

## INSTALLATION OF CONTROL, SCANNERS, AND FLAME DETECTORS

### Wiring Base

Mount the control in an enclosure/burner panel that provides the proper protection for the control. The location should be free from moisture, excessive vibration and within the specified ambient temperature rating. The control may be mounted in any angular position.

All wiring should comply with applicable electrical codes, regulations, and local ordinances. Use moisture resistant wire suitable for at least 90 degrees C. Circuit recommendations are found on pages 10 through 11. Consult the factory for assistance with non-standard applications.



**WARNING: Installer must be trained and qualified. Follow the burner manufacturer's instructions, if supplied. Otherwise, proceed as follows.**

**WARNING: Controls require safety limits utilizing isolated mechanical contacts. Solid state limit switches are not acceptable and should not be used due to their high leakage currents.**

**WARNING: Remove power from the control before proceeding.**

### Replaceable Fuse

The M4RT1 is designed with a field replaceable fuse. The fuse is located on the printed circuit board. The fuse will blow as a result of an overload condition on Terminals 3, 4 or 5. To replace the fuse, remove power from the system. Using a small screwdriver or similar tool, remove the fuse from its holder. Install a Fireye replacement fuse (P/N 23-176) or equivalent 8 amp fuse (e.g. Littelfuse 225008P, 8 amp, 125V).



**WARNING: Turn off the power when installing or removing the control.**

## INSTALLATION - 69ND1 FLAME ROD

The 69ND1 flame rod proves a gas pilot flame and/or main gas flame. It is a *spark plug* type unit consisting of  $\frac{1}{2}$ " NPT mount, a KANTHAL flame rod, a glazed porcelain insulating rod holder and a spark plug connector for making electrical connections. The 69ND1 is available in 12," 18" or 24" lengths.

The flame rod may be located to monitor only the gas pilot flame or both the gas pilot and main gas flames. It is mounted on a  $\frac{1}{2}$ " NPT coupling.

The following instructions should be observed:

1. Keep flame rod as short as possible.
2. Keep flame rod at least  $\frac{1}{2}$ " from any refractory.
3. Flame rod should enter the pilot flame from the side so as to safely prove an adequate pilot flame under all draft conditions.
4. If the flame is nonluminous (air and gas mixed before burning), the electrode tip should extend at least  $\frac{1}{2}$ " into the flame, but not more than halfway through.

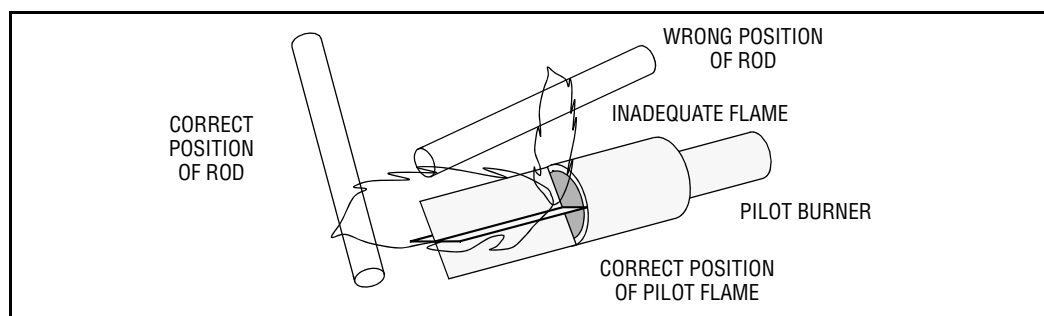

5. If the flame is partly luminous, the electrode tip should extend only to the edge of the flame. It is not necessary to maintain absolutely uninterrupted contact with the flame.
6. It is preferable to angle the rod downward to minimize the effect of sagging and to prevent it from coming in contact with any object.
7. An adequate grounding surface for the flame must be provided. The grounding surface in actual contact with the flame must be at least four times greater than the area of the portion of the flame rod in contact with the flame. It is essential to adjust the flame rod and ground area ratio to provide a minimum signal reading of 6.0 VDC.

*Note: Interference from the ignition spark can alter the true signal reading by adding to, or subtracting from it. This trend sometimes may be reversed by interchanging the primary wires (line voltage) to the ignition transformer. This interference can also be reduced by the addition of grounded shielding between the flame rod and ignition spark.*

8. Proven types of flame grounding adapters, as shown below, may be used to provide adequate grounding surface. High temperature stainless steel should be used to minimize the effect of metal oxidation. This assembly may be welded directly over the pilot or main burner nozzle.

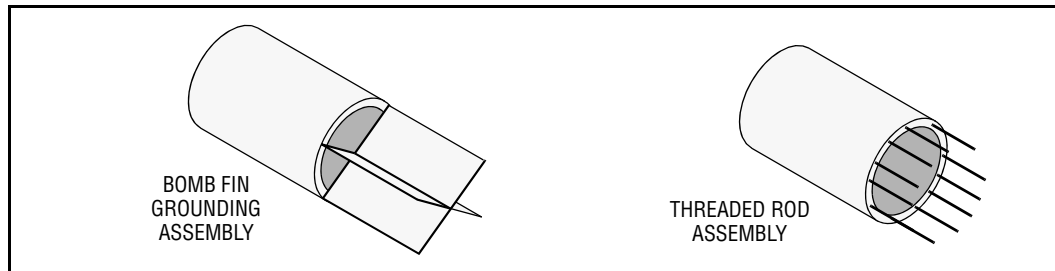

---

## WIRING OF FLAME RODS

For proper operation of flame rectification systems, it is necessary to maintain at least 20 megohms insulating resistance in the flame rectification circuit.

1. The scanner should be wired using metal cable or rigid conduit.
2. High voltage wiring must not be installed in the same conduit with scanner wiring.

### Selection of Scanner Wire

1. Use #14, 16, or 18 gauge wire with 90 C, 600 volt insulation for up to 20 feet distance.
2. The type of insulation used with flame rectification is important, since it must protect against current leakage resistance to ground. Use Belden 8254-RG62 Coaxial Cable (or equal) for runs greater than 20 feet. **Maximum wiring run not to exceed 100 feet.**

---

## MAINTENANCE

### Type 69ND1 Flame Rod

The flame rod and its insulator should be kept clean by washing routinely with soap and water. Rods should be routinely replaced as they oxidize.

### Flame Signal Strength

Routine observation of the flame signal strength will forewarn any deterioration in the capability of the flame detector or its application.

### Periodic Safety Check

It is recommended that a procedure be established to test the complete flame safeguard system at least once a month. This test should verify the proper operation of all limit switches and safety interlocks as well as flame failure protection and fuel safety shutoff valve tightness.

## RESET

In the event of a lockout condition, the M4RT1 can be reset via a minimum one second power interruption to terminal 7.

### RESET OPTIONS (Special Order)

1. Optional M4RT1 reset push button. When this optional reset pushbutton is installed, the M4RT1 can be reset by depressing this button for a minimum of one second.
2. Remote reset option. With this option, the M4RT1 is provided with two additional screw terminals. Using those terminals, a remote, dry contact pushbutton switch can be connected. The maximum wire length is 100 feet (no.18 AWG wire size is recommended).



**CAUTION:** Remote reset is recommended only on a control solely for proved ignition programming (pilot ignited burner) or a control for use only with appliances in which unburned fuel cannot accumulate and that is intended for installation in inaccessible locations such as open-flame, ceiling-suspended gas heaters.



**WARNING:** Selection of the Purge time and Recycle / Non-Recycle operation for a particular application, by changes to the factory default jumpers described below, should only be performed by a competent professional, licensed by a state or other government agency. Inappropriate selection of these safety critical parameters could result in an unsafe condition hazardous to life and property.

## PROGRAMMER JUMPER SETTINGS

The M4RT1 has a series of 8 jumpers that are used to configure the Purge timing, Pilot Trial for Ignition (PTFI) timing, and recycle or non-recycle operation.

### Purge Timing

Jumpers JP1 through JP5 are used to select the Purge timing for the M4RT1. The available Purge timing selections are 5, 7, 30, 60, and 240 seconds and any additive combination of those times. Selecting two or more Purge timing jumpers will result in a Purge time period equal to the sum of the jumpers selected. Selection of a Purge time is accomplished by cutting or not installing the associated jumper. The factory set, default Purge time of 5 seconds (JP1 not installed) is always selected.

The Table below lists all available Purge times and how to select those by cutting jumpers JP2 through JP5.

Purge Time (seconds)	JP2	JP3	JP4	JP5
5	Installed	Installed	Installed	Installed
12	Cut	Installed	Installed	Installed
35	Installed	Cut	Installed	Installed
42	Cut	Cut	Installed	Installed
65	Installed	Installed	Cut	Installed
72	Cut	Installed	Cut	Installed
95	Installed	Cut	Cut	Installed
102	Cut	Cut	Cut	Installed
245	Installed	Installed	Installed	Cut
252	Cut	Installed	Installed	Cut
275	Installed	Cut	Installed	Cut
282	Cut	Cut	Installed	Cut
305	Installed	Installed	Cut	Cut
312	Cut	Installed	Cut	Cut
335	Installed	Cut	Cut	Cut
342	Cut	Cut	Cut	Cut



### Pilot Trial for Ignition

Jumpers JP6 and JP7 are used by the factory only to select the PTFI for the M4RT1. The available PTFI timing selections are 5 and 10 seconds. The factory set, default PTFI time is 10 seconds (JP6 installed, JP7 not installed). The PTFI time may only be set by the factory.

### Recycle/Non-recycle Operation

Jumper JP8 is used to select either Recycle or Non-Recycle operation of the M4RT1. The factory set, default is Recycle operation (JP8 installed). To select Non-Recycle operation, cut jumper JP8.

---

## LED INDICATOR LIGHTS

The M4RT1 has 5 LED lights to indicate the operating status of the control. The function of these lights are:

**Opr Ctrl (Operating Control):** This LED is lighted whenever input terminal 7 is energized. The burner system safety interlocks and operating control should be wired in series and connected to the M4RT1 terminal 7.

**Air Flow:** This LED is lighted whenever all of these conditions exist:

- Input terminal 7 is energized (operating control and safety interlocks closed).
- Input terminal 6 is energized (proof of airflow switch is closed).
- Output terminal 8 is energized (blower motor).

**PTFI:** This LED is energized only during the Pilot Trial For Ignition Period.

**Flame:** This LED is lighted whenever an adequate flame signal is detected between the M4RT1 terminals S1 & S2.

**Alarm:** This LED is energized whenever a safety lockout occurs. (See APPLICATION AND FUNCTION section).

*NOTE: The M4RT1 is not powered until the user's operating control is energized.*

---

## APPLICATION AND FUNCTION

The M4RT1 provides prepurge, ignition and flame safeguard for heating and process gas fired burners. The “recycle” or “non-recycle” operation is determined by the #8 jumper on the top PCB. Purge timing, as well as trial for ignition timing is also set by the jumpers. See JUMPER SETTINGS on page 5.

The M4RT1 amplifier circuitry is designed to utilize a flame rod for flame detection. The Flame Failure Response Time (F.F.R.T.) is fixed at 3 seconds.

### Pilot Ignited Burners - “Recycle” Operation

With jumper #8 in the “recycle” position, the typical wiring arrangement illustrated on page 10 for pilot ignited burners provides the following function:

1. With power applied to Terminal 7 (Opr Ctrl LED lighted), the burner motor circuit (Terminal 8) is energized. The control then waits for the proof of airflow input (Terminal 6) to be energized
2. The Pre-Purge timing starts when terminal 6 is energized.
3. Following the prepurge period (as determined by jumpers #1 through #5), KL-1 closes, energizing Terminal 3 which powers the pilot gas valve and Terminal 4 which powers the spark ignition. A five or ten sec. (as determined by jumpers #6 or #7) trial for ignition is initiated (PTFI LED lit).
4. When pilot flame is detected (Flame LED lit), KF-1 closes, energizing Terminal 5 which powers the main fuel valve, KF-2 opens de-energizing Terminal 4 which shuts off the spark ignition.
5. When the operating control opens its circuit, or if a power failure occurs, the entire system is de-energized. Power interruptions in the millisecond range do not affect the operation of the control. Power interruptions of longer duration will cause the control to recycle.



6. In the event the pilot flame is not detected by the end of trial for ignition period (PTFI), the pilot gas valve (Terminal 3) and spark ignition (Terminal 4) are de-energized. A safety shutdown occurs followed in approximately 30 seconds by a safety lockout that de-energizes the blower motor (Terminal 8) and energizes the lockout alarm circuit (Alarm LED lighted).
7. In the event of a flame failure during a firing period, the pilot and main fuel valves are de-energized. Following the prepurge period (as determined by jumpers #1 through #5), with proven air flow (Air Flow LED lit), the pilot gas valve and spark ignition are re-energized and a five or ten sec. (as determined by jumpers #6 or #7) trial for ignition is initiated (PTFI LED lit). If pilot flame is detected (Flame LED lit), the main fuel valve is energized, the spark ignition is de-energized. In the event the pilot flame is not detected by the end of trial for ignition period (PTFI), the pilot gas valve (Terminal 3) and spark ignition (Terminal 4) are de-energized. A safety shutdown occurs followed in approximately 30 seconds by a safety lockout that de-energizes the blower motor (Terminal 8) and energizes the lockout alarm circuit (Alarm LED lighted).
8. Manual Reset (supply power cycled off/on) is required following any safety lockout.

*NOTE: Wait 10 seconds after lockout before restarting the control.*

#### **Pilot Ignited Burners - "Non-recycle" Operation**

The function of "non-recycle" pilot ignited burners is the same as described for the "recycle" controls, except that the "non-recycle" operation will lock out following any flame failure. "Recycle" or "non-recycle" operation is determined by the position of jumper #8. See Programmer jumper settings on page 5.

#### **Direct Spark Ignited Burners - "Recycle" Operation**

With jumper #8 in the "recycle" position, the typical wiring arrangement illustrated on pages 10 and 11 for direct spark ignited burners provides the following function:

1. With power applied to Terminal 7 (Opr Ctrl LED lighted), the burner motor circuit (Terminal 8) is energized. The control then waits for the proof of airflow input (Terminal 6) to be energized.
2. The Pre-Purge timing starts when terminal 6 is energized.
3. Following the selected prepurge period (as determined by jumper #1 through #5), KL-1 closes, energizing Terminal 3 which powers the primary main fuel valve, and Terminal 4 which powers the spark ignition. A five or ten second (as determined by jumper #6 and #7) trial for ignition is initiated (PTFI LED lit).
4. When pilot flame is detected (**Flame** LED lit), KF-1 closes, energizing Terminal 5 which powers the secondary main fuel valve, and KF-2 opens, de-energizing Terminal 4 which shuts off the spark ignition.
5. When the operating control opens its circuit, or if a power failure occurs, the control is de-energized. Power interruptions in the millisecond range do not affect the operation of the control. Power interruptions at longer duration will cause the control to recycle.
6. In the event the pilot flame is not detected by the end of trial for ignition period (PTFI), the pilot gas valve (Terminal 3) and spark ignition (Terminal 4) are de-energized. A safety shutdown occurs followed in approximately 30 seconds by a safety lockout that de-energizes the blower motor (Terminal 8) and energizes the lockout alarm circuit (Alarm LED lighted).

#### **Direct Spark Ignited Burners - "Non-recycle" Operation**

The function of "non-recycle" direct spark ignited burners is the same as described for the "recycle" controls, except that the "non-recycle" operation will lock out following any flame failure. "Recycle" or "non-recycle" operation is determined by the position of jumper #8. See Programmer Jumper Settings on page 5.



## TIMING CHART

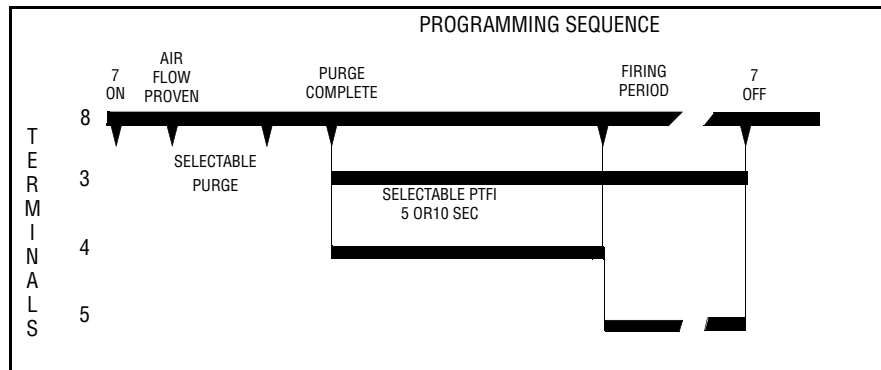

Selectable Recycle/Non-Recycle operation on loss of flame after Terminal 5 energized. Recycle on loss of air flow after flame proven.

## INSTALLATION TESTING

### Use of Test Meter

Testing the Fireye M4RT1 Control requires the use of a test AC-DC multimeter, with a 1,000 ohm/volt DC rating or greater, or a digital meter with 500K input impedance or greater.

With the test meter on the DC scale, and the test meter leads inserted into the test jacks. A **steady** DC voltage reading of **6 to 18 volts** should be obtained when the control is detecting flame, and zero volts when no flame is present.

With the test meter on the AC scale, line and load voltages may be measured at the identified test points on the chassis.

On the M4RT1 control, a micro-ammeter may be connected in series with the wire to Terminal S2. Normal flame will produce a meter reading between 4 and 10 micro-amperes.

### Flame Signal Testing

1. Manually shut off the main fuel valve for a pilot ignited burner, or the secondary fuel valve for a direct spark ignited burner.
2. Set the test meter on the DC scale and insert the test leads into the test jacks on the amplifier module. (If the meter reads backwards, reverse the meter leads). Red - Plus, Black - Negative.
3. Initiate a normal startup.
4. When flame is established, the test reading should be normal: a steady DC voltage reading of 6 to 18 volts.
5. Inadequate flame signal may be improved by:
  - a Assuring that the flame detector and wiring installations have followed the instructions on pages 3 and 4.
  - b Assuring that the flame detector is clean and within the ambient temperature limits.
  - c Assuring that the flame is sufficiently large to detect.
  - d Assuring that the flame quality (fuel to air ratio, combustion air velocity) is satisfactory.

### Minimum Pilot Test

This test insures that the flame detector will not sense a pilot flame too small to light the main flame reliably. It must be made on every new installation as well as following the repositioning of the flame detector. **This procedure should not be used on a direct spark ignited burner.**

1. Manually shut off the fuel to the main burner.
2. Connect a test meter to the test jacks.
3. Initiate a normal startup.
4. Reduce the fuel to the pilot until the DC voltmeter reads approximately 6 volts or when the pilot is at the minimum to provide a reliable main flame light-off. See WARNING below. This is the minimum pilot.
5. Slowly turn on the main fuel and insure that the main flame lights off promptly and normally.



**WARNING: If light off is delayed, shut off the power to the installation. Realign the flame detector so that pilot flame detection requires a larger pilot flame. Repeat this test until the main flame lights reliably with minimum pilot.**

**WARNING: The minimum pilot test must be accomplished by a trained and qualified burner technician.**

6. After the minimum pilot test is completed satisfactorily, increase the pilot flame to normal size, and observe that the main flame is properly established during a normal cycle ("Run-Check" switch in the "Run" position).

### Flame Failure Test

1. Temporarily connect spark ignition and pilot valve to Terminal #3.
2. Initiate a normal startup.
3. Manually shut off all fuel and observe the loss of flame signal on the test meter.
4. If flame signal does not reduce to zero within the flame failure response time of the control, a grounded metallic shield may need to be inserted between the flame rod and spark ignition to prevent interference.



5. **IMPORTANT:** When the test is completed, reconnect the spark ignition to Terminal #4.

**FIGURE 1. TYPICAL WIRING ARRANGEMENT FOR PILOT IGNITED BURNER.**

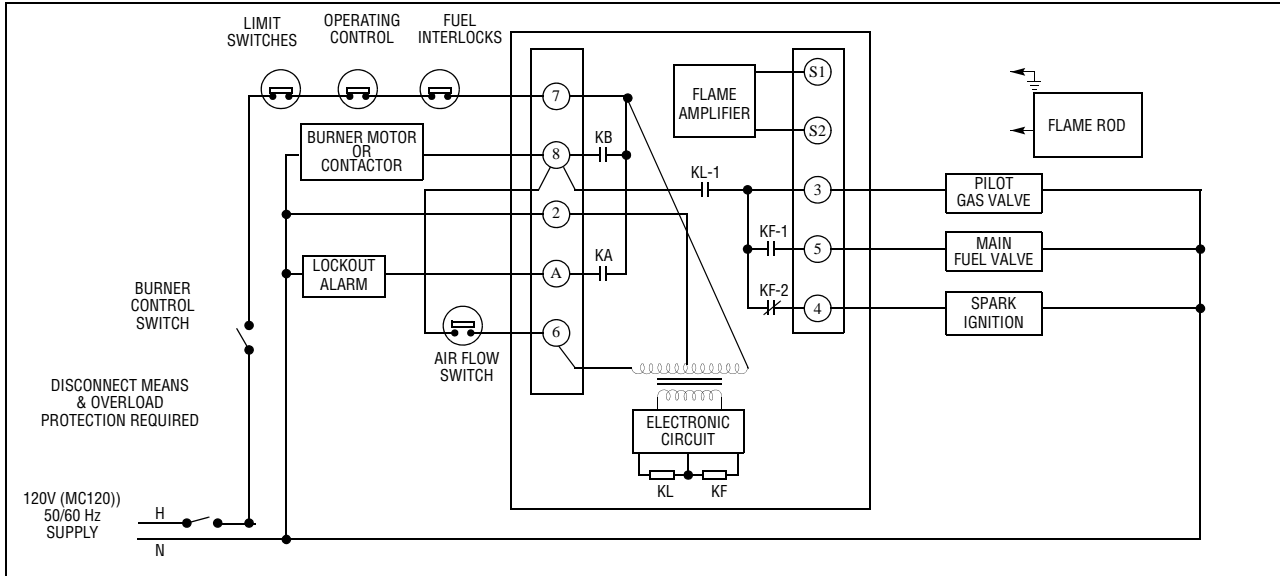

Use moisture resistant wire suitable for at least 90°C.



**CAUTION:** When powered, 260 VAC across S1, S2.

**FIGURE 2. TYPICAL WIRING ARRANGEMENT FOR DIRECT SPARK IGNITED BURNER**

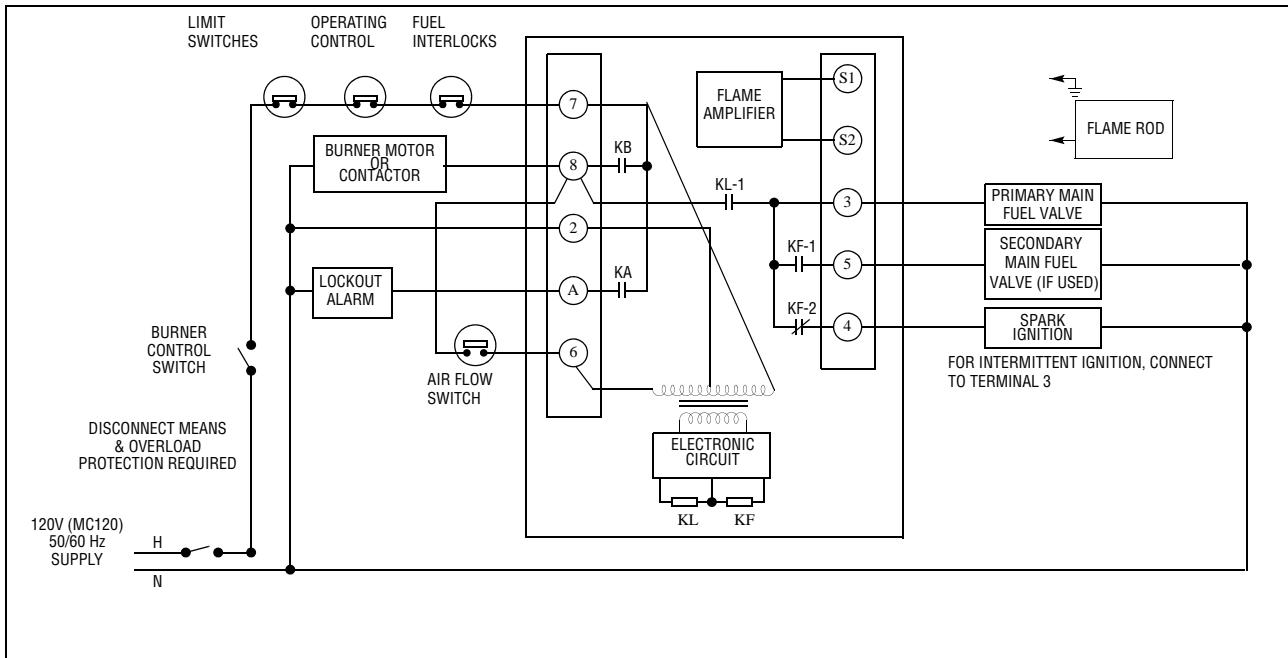

Use moisture resistant wire suitable for at least 90°C.



**CAUTION:** When powered, 260 VAC across S1, S2.



**CAUTION:** Control wiring procedures which deviate from those shown in the diagrams may bypass safety functions designed in the control. Check with the Fireeye Representative before deviating from the recommended wiring diagrams.

**FIGURE 3. ALTERNATE WIRING ARRANGEMENT**

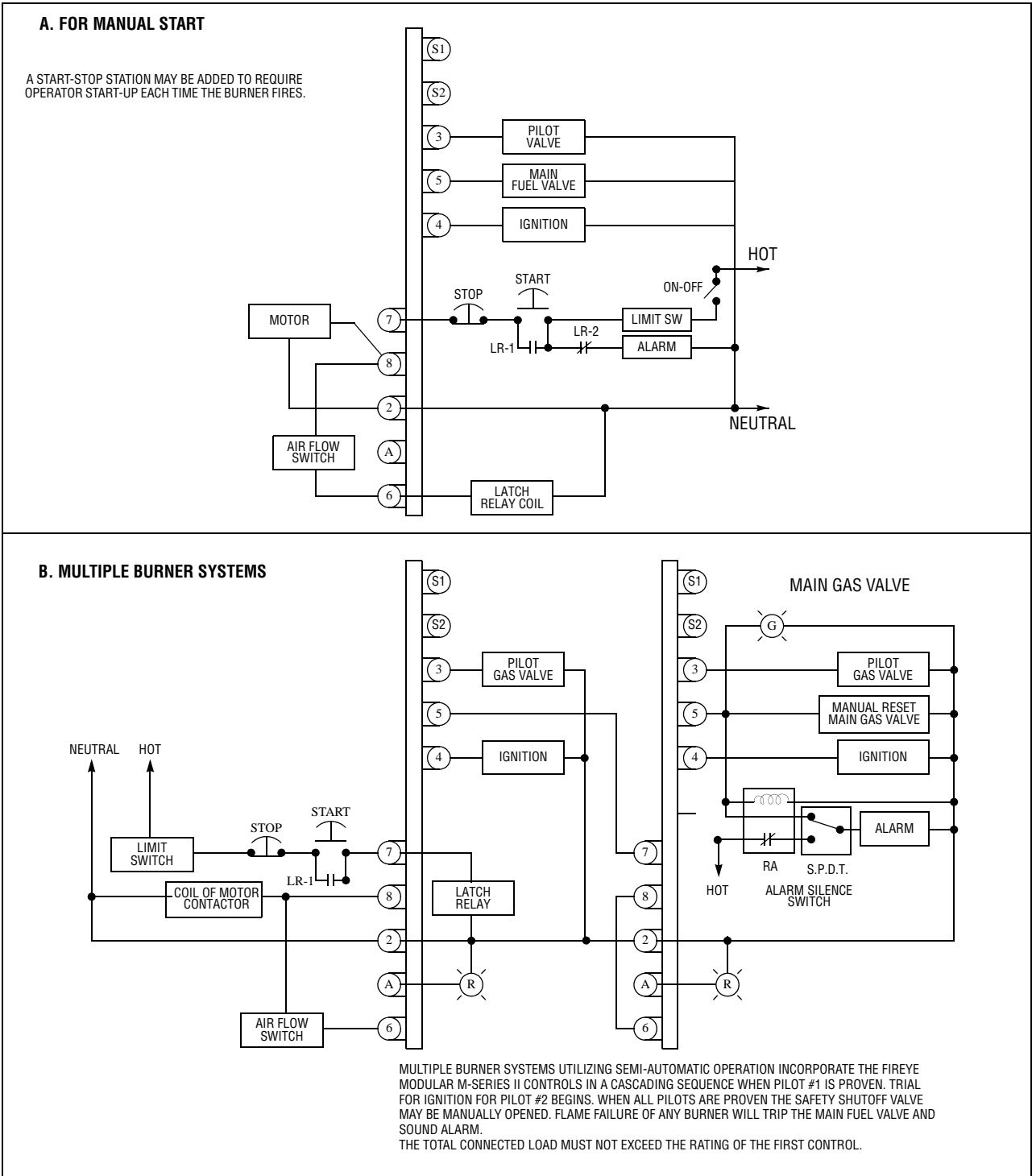

Use moisture resistant wire suitable for at least 90°C.



**CAUTION:** Control wiring procedures which deviate from those shown in the diagrams may bypass safety functions designed in the control. Check with the Fireye Representative before deviating from the recommended wiring diagrams.



---

## NOTICE

When Fireeye products are combined with equipment manufactured by others and/or integrated into systems designed or manufactured by others, the Fireeye warranty, as stated in its General Terms and Conditions of Sale, pertains only to the Fireeye products and not to any other equipment or to the combined system or its overall performance.

---

## WARRANTIES

FIREYE guarantees for *one year from the date of installation or 18 months from date of manufacture* of its products to replace, or, at its option, to repair any product or part thereof (except lamps, electronic tubes and photocells) which is found defective in material or workmanship or which otherwise fails to conform to the description of the product on the face of its sales order. **THE FOREGOING IS IN LIEU OF ALL OTHER WARRANTIES AND FIREYE MAKES NO WARRANTY OF MERCHANTABILITY OR ANY OTHER WARRANTY, EXPRESS OR IMPLIED.** Except as specifically stated in these general terms and conditions of sale, remedies with respect to any product or part number manufactured or sold by Fireeye shall be limited exclusively to the right to replacement or repair as above provided. In no event shall Fireeye be liable for consequential or special damages of any nature that may arise in connection with such product or part.



---

FIREYE  
3 Manchester Road  
Derry, New Hampshire 03038  
[www.fireeye.com](http://www.fireeye.com)

M-4000  
JANUARY 29, 2007  
Supersedes Jan. 18, 2007