

# Selectra®

## 14 & 44 Condensed Catalog

### Electronic Modulation Gas-Fired Temperature Controls/ Direct Fired Applications

Selectra® systems from Maxitrol maintain precise, stable gas-fired temperatures. Selectra's unique electronic Modulator or Modulator-Regulator valves control gas flow with instantaneous response and continual adjustment. They are the superior alternative to mod motors and butterfly valves.

OEM or retrofit applications include environmental climate control, as well as industrial or commercial heating processes. Standard temperature adjustment range 55° to 90° F. All fuel gases are compatible - capacities to 30,000,000 Btu/h.

Available standard companion electronics include temperature selectors, amplifiers, and temperature sensors, in a variety of configurations. The amplifier supplies output voltage to the M/MR valve.

### MAKE UP AIR APPLICATIONS Series 14 System

Selectra® Series 14 systems are designed primarily for make-up air heating, as components of direct fired equipment.

A discharge air temperature sensor is mounted within a mixing tube housing.

Amplifiers are available with low-fire start duration, and integral or remote temperature selection.

#### Options:

- A room override thermostat provides space temperature control by raising the discharge air temperature to a preselected point - when used in conjunction with the remote temperature selector.
- An inlet air sensor (and mixing tube) provides inverse change in discharge air for each degree change in inlet air - when installed in a convenient duct location upstream of the burner.
- A dual temperature selector replaces TD114 to provide dual control for door heaters, or other applications such as paint spray booths.

### SPACE HEATING APPLICATIONS Series 44 System

Selectra® Series 44 systems are designed primarily for space heating, as components of direct fired equipment.

A wall mounted Selectrastat® senses space temperature and has an integral selector with either a 55° to 90° F or 40° to 80° F range. A discharge air temperature sensor (and mixing tube) is a means of limiting the minimum and maximum discharge air temperature.

Amplifiers are available with low-fire start duration feature.

#### Option:

- Instead of a Selectrastat, a separate remote temperature sensor and selector can be substituted.



Figure 1 : MR212



Figure 2 : M611







Figure 3 : M411



# MAKE UP AIR APPLICATIONS - Series 14 System

Series 14 Basic System					Options	
Valves	Amplifier or Amplifier-Selector	Selection Method	Remote Selector Model (if applicable)	Sensor	Override Stat	Inlet Air Sensor
M411, M511, M611, MR212D, E, G, or J (see pg. 4)	A1014, A1014U	Single Remote	TD114	TS114/ MT1 or 2	T115	TS10765
		Dual Remote	TD114HD	TS114/ MT1 or 2	—	—
	AD1014U	Single Integral	—	TS114/ MT1 or 2	—	TS10765
	AD1214	Dual Integral	—	TS214/ MT1 or 2	—	—

Note: Selector and sensor must have the same temperature range to be compatible.

## SYSTEM COMPONENTS

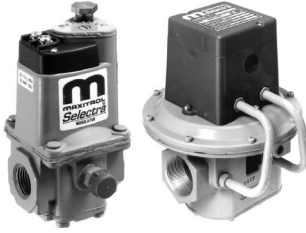
<b>Amplifiers (A1014 shown)</b>	
	A1014 (all temperature ranges) A1014U (replaces A1014L1, suitable replacement for A1014)(all temperature ranges - includes 10 or 20 second low fire start capability)
<b>Amplifier-Selectors (with integral temperature dial)</b>	
	AD1014U (shown) (replaces AD1014 and AD1014L1)(all temperature ranges - includes 10 or 20 second low fire start capability)
<b>Dual Temperature Amplifier-Selectors: (AD1214 shown)</b>	
	AD1214__ (integral dual selector - any comb. of 2 standard ranges avail.) Example1 - AD1214BC (120° to 170° F and 160° to 210° F, use w/TS214BC Example2 - AD1214AD (80° to 130° F and 200° to 250° F, use w/TS214AD
<b>Remote Temperature Selectors:</b>	
	TD114 (55° to 90° F w/override 0° to 40° over set point) TD114A (80° to 130° F) TD114A-1 (80° to 130° F w/ override 0° to 40° F over set point) TD114B (120 to 170° F) TD114C (160° to 210° F) TD114D (200° to 250° F)
TD114E (100° to 250° F) TD114F (40° to 80° F w/override 0° to 40° over set point) TD114G (90° to 140° F) TD114-1 (55° to 90° F w/120° to 170° F override) * use w/TS114 TD114-2 (55° to 90° F w/two outputs) TD114G-2 (90° to 140° F w/two outputs) NOTE: Remote Selector and Discharge Temperature Sensor must have same temperature range to be compatible. Optional: ETD-1 enclosure, EFP-1 cover plate only - no enclosure	
<b>Discharge Air Temperature Sensors: use with Mixing Tube</b>	
TS114 (55° to 90° F) TS114A (80° to 130° F) TS114B (120° to 170° F) TS114C (160° to 210° F) TS114D (200° to 250° F) TS114E (100° to 250° F) TS114F (40° to 80° F) TS114G (90° to 140° F) TS114J (110° to 160° F) To be used w/ AD1014-1116	

TS214__ (dual sensor - any combination of 2 standard ranges available) Example 1 - TS214G (55° to 90° F and 90° to 140° F, use w/TD114 & TD114G, or TD214G [selector w/switch], or AD1214G) Example 2 - TS214AD (80° to 130° F and 200° to 250° F, use w/TD114A & TD114D, or TD214AD [selector w/ switch], or AD1214AD)	
<b>Mixing Tubes: (and sensor)</b>	
	MT1-9 or 2-9 (9" length) MT1-12 or 2-12 (12" length) MT1-23 or 2-23 (23" length) MT1-28 or 2-28 (28" length) MT1-57 (57" length)
<b>Valves:</b>	
	M411 (3/8" & 1/2" pipe size) M511 (1/2" & 3/4" pipe size) M611 (3/4" & 1" pipe size) MR212D (1", 1-1/4", 1-1/2" pipe size) MR212E (1-1/2" & 2" pipe size) MR212G (2-1/2" & 3" pipe size) MR212J (4" flanged) MR212-2D, E, G, J (used for 2-speed blower or dual fuel operation) NOTE: M (Modulator) valve requires a pressure regulator for high fire setting. MR (Modulator-Regulator) valve requires no pressure regulator up to 5 psi.
	









<b>OPTIONAL SYSTEM COMPONENTS:</b>	
<b>Dual Temperature Selector:</b>	
DOOR HEATERS -TD114HD use w/TS114 (door closed 55° to 90° F/open 90° to 140° F) PAINT SPRAY BOOTHS OR OTHER DUAL APPLICATIONS- TD214__ (dual selector w/switch - any comb. of 2 standard ranges avail.) Example 1-TD214G(55° to 90° F [spray]and 90° to 140° F [dry], use w/TS214G Example 2 - TD214AD (80° to 130° F and 200° to 250° F, use w/TS214AD TD214__X (same as TD214__, less enclosure)	
<b>Inlet Air Temperature Sensors: use with Mixing Tube</b>	
TS10765A (8:1 ratio) TS10765B (5:1 ratio) TS10765C (3.5:1 ratio)	
<b>Override Stat: (use only with TD114, F, -1, A-1)</b>	
	T115 (40° to 90° F)

# SPACE HEATING APPLICATIONS - Series 44 System

Series 44 Basic System				Options	
Valves	Amplifier	Selectrstat	Discharge Temp. Sensor	Space Temperature Selector	Space Temperature Sensor
M411, M511, M611, MR212D, E, G, or J (see pg. 4)	A1044, A1044U	T244	TS144 / MT1 or 2	TD244	TS244

Note: Selector and sensor must have same temperature range to be compatible.

## SYSTEM COMPONENTS

Amplifiers		Valves	
 <p>A1044U</p>	<p>A1044U (replaces all A1044L1, suitable replacement for A1044 [C,D,E,H]) (includes 0, 10, or 20 second low fire start capability.)                      A1044UF (replacement for A1044FL1)                      A1044UG (replacement for A1044G[L1])</p>		<p>M411 (3/8" &amp; 1/2" pipe size)                      M511 (1/2" &amp; 3/4" pipe size)                      M611 (3/4" &amp; 1" pipe size)                      MR212D (1", 1 1/4", 1 1/2" pipe size)                      MR212E (1 1/2" &amp; 2" pipe size)                      MR212G (2 1/2" &amp; 3" pipe size)                      MR212J (4" flanged)                      MR212D-2, E-2, G-2 &amp; J-2 (same pipe sizes as MR212D-J except used for 2-speed blower or dual fuel operation)</p>
 <p>A1044 Amplifier</p>	<p>A1044 (min. 40° to 80° F / max. 80° to 140° F)                      A1044C (min. 20° to 60° F / max. 80° to 140° F)                      A1044D (min. 20° to 60° F / max. 35° to 75° F)                      A1044E (min. 20° to 60° F / max. 60° to 120° F)                      A1044G (min. 40° to 80° F / max. 160° to 210° F)                      A1044H (min. 40° to 80° F / max. 100° to 160° F)</p>		<p><b>NOTE:</b> M (Modulator) valve requires an upstream pressure regulator for low fire &amp; high fire settings. MR (Modulator/Regulator) valve requires no upstream pressure regulator up to 5 psi inlet.</p>
 <p>A1044L Amplifier</p>	<p><b>NOTE:</b> Amplifier and Discharge Temperature Sensor must have same temperature range to be compatible.</p>	<p><b>Selectrstat (Senses and Selects)</b></p>	
<p><b>Discharge Temperature Sensors: use with Mixing Tube</b></p>			<p>T244 (55° to 90° F)                      T244A (40° to 80° F)                      or optional pair to replace Selectrstat</p>
<p>Sensors compatible with A1044U:                      TS144 (min. 40° to 80° F / max. 80° to 140° F)                      TS144C (min. 20° to 60° F / max. 80° to 140° F)                      TS144D (min. 20° to 60° F / max. 35° to 75° F)                      TS144E (min. 20° to 60° F / max. 60° to 120° F)                      TS144H (min. 40° to 80° F / max. 100° to 160° F)</p>		<p>Sensors compatible with A1044UF:                      TS144F (min. 40° to 80° F / max. 60° to 95° F)                      Sensors compatible with A1044UG:                      TS144G (min. 40° to 80° F / max. 160° to 210° F)</p>	
<p><b>Mixing Tubes: used with sensors</b></p>			<p>TD244 (wall mount 55° to 90° F)                      TD244A (wall mount 40° to 80° F)                      TD244P (panel mount 55° to 90° F)                      TD244AP (panel mount 40° to 80° F)</p>
<p>MT1-9 or MT2-9 (9" length)                      MT1-12 or MT2-12 (12" length)                      MT1-23 or MT2-23 (23" length)                      MT1-28 or MT2-28 (28" length)                      MT1-57 (57" length)</p>		<p><b>Space Temperature Selector</b></p>	
			<p>TS244 (55° to 90° F)                      TS244A (40° to 80° F)</p>
		<p><b>Space Temperature Sensor</b></p>	
			<p><b>NOTE:</b> Space Temperature Selector and Space Temperature Sensor must have same temperature range to be compatible.</p>

# PRESSURES, DIMENSIONS

## Valve Dimensions - in inches (millimeters)

Dimensions are to be used only as an aid in designing clearance for the valve.  
Actual production dimensions may vary somewhat from those shown.

Model Number	Swing Radius	Call-Outs			
		A	B	C	D
M411	3.1 (79)	3.9 (100)	2 (51)	2.1 (54)	.9 (24)
M511	4.3 (109)	5.3 (135)	3.25 (83)	3.4 (86)	1.2 (30)
M611	7.2 (183)	7.4 (188)	3.9 (99)	4 (102)	1.5 (37)
MR212D	8.1 (206)	10.2 (259)	7 (178)	5.5 (140)	2.3 (59)
MR212E	8.6 (218)	11.25 (286)	9.1 (232)	8 (203)	3 (76)
MR212G	10.4 (264)	14.75 (375)	13.5 (343)	11.75 (298)	4.6 (118)
MR212J*	—	24 (610)	21.5 (546)	13.9 (352)	5.9 (149)

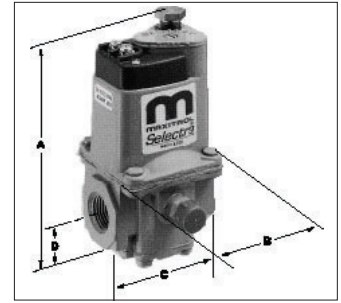

Figure 4 : M411, 511

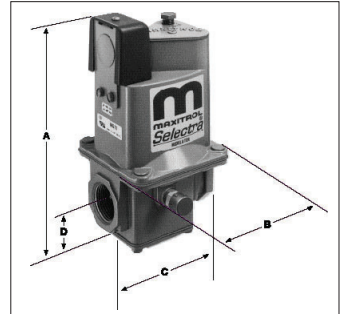

Figure 5 : M611

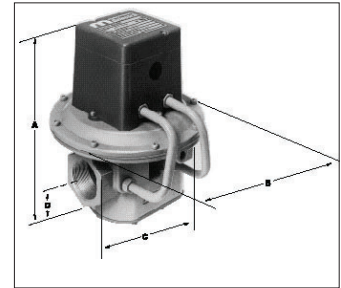

Figure 6 : MR212



M411, M511, M611 - CSA tested for 1/2 psi inlet pressure, Maxitrol tested for 1 psi maximum operating inlet pressure.

MR212D, E, G, J - CSA rated for 5 psi inlet pressure, Maxitrol tested for 5 psi maximum operating inlet pressure.

See Bulletin MMR\_MT\_EN for additional valve information.

### Series 14 System

A1014 Amplifier  
4.51" (115) x 2.62" (67) x 1.34" (34)

AD1014 Amplifier/Selector, A1014U Amplifier  
6" (152) x 3.38" (86) x 2" (51)

AD1214 Dual Temp. Amplifier-Selector  
5.75" (146) x 2.62" (67) x 1.34" (34)

TD114 Remote Temp. Selector  
2.62" (67) x 3" (76) x 1.75" (44)

TD114S Dual Temp. Selector  
6" (152) x 4" (102) x 2" (51)

T115 Override Stat  
2.96" (75) x 4.69" (119) x 2.56" (65)

ETD- 1 (opt. TD114 enclosure), MT1 Mixing Tube encl. (for sensor)  
4.19" (106) x 4.19" (106) x 1.88" (48)  
[Tube lengths: 9" (229), 12" (305), 23" (584), 28" (711), 57" (1448)]

MT2 Mixing Tube enclosure (for sensor)  
2.19" (56) x 4.19" (106) x 1.88" (48)  
[Tube lengths: 9" (229), 12" (305), 23" (584), 28" (711)]

### Series 44 System

A1044 Amplifier  
5.75" (146) x 2.62" (67) x 1.34" (34)

A1044L Amplifier  
6" (152) x 3.38" (86) x 2" (51)

T244 Selectrastat  
2.56" (65) x 4.5" (114) x 1.79" (46)

TD244 Space Temp. Selector  
2.56" (65) x 4.5" (114) x 1.79" (46)

TS244 Space Temp. Sensor  
2.56" (65) x 4.5" (114) x 1.53" (39)

MT1 Mixing Tube enclosure (for TS144 sensor)  
4.19" (106) x 4.19" (106) x 1.88" (48)  
[Tube lengths: 9" (229), 12" (305), 23" (584), 28" (711), 57" (1448)]

MT2 Mixing Tube enclosure (for TS144 sensor)  
2.19" (56) x 4.19" (106) x 1.88" (48)  
[Tube lengths: 9" (229), 12" (305), 23" (584), 28" (711)]

Dimensions are to be used only as an aid in designing clearance. Actual production dimensions may vary somewhat from those shown.

**MAXITROL**