



R851B STEP CONTROLLER WITH INTEGRATED VERNIER STAGE

- Analog 0 to 10 Vdc vernier stage
- 4 or 8 step models
- Up to 16 stage total with a slave unit
- Test button



DESCRIPTION

The Viconics R851B series step controller is designed for cost effective, precise modulation of multi-stage control application. A common application is a multi step electric boiler.

An integrated vernier control output will give a precise and full modulation of the load from 0 to 100% of the total capacity.

FEATURES AND BENEFITS

Microcomputer-based design	Accuracy and reliability
Adjustable step-up and step-down time delay	Tailor to exact application
Adjustable Vernier ratio	Simplifies design of proportional stage
0-10 Vdc analog Vernier output	Permits use of SCR power controller
Up to 16 stages	One product family can handle all applications
Progressive or linear sequencing	Increased flexibility
Test button	Quick troubleshooting

MODELS AVAILABLE

The R851-V is available in 2 models

- **R851B-4** 4 stage unit
- **R851B-8** 8 stage unit

If more than 8 stages are required, the R851B-8 can be used as a master unit with another R851B as a slave unit. Adding another unit (R851B-4 or R851B-8) can bring the total step number up to 12 or 16.

INPUT SIGNAL

The R851B has four **INPUT** dip switch (**S1** to **S4**) to select the control signal input: They are compatible with industry standard signals.

DIP SWITCH ADJUSTMENTS & WIRING CONTROL INPUT

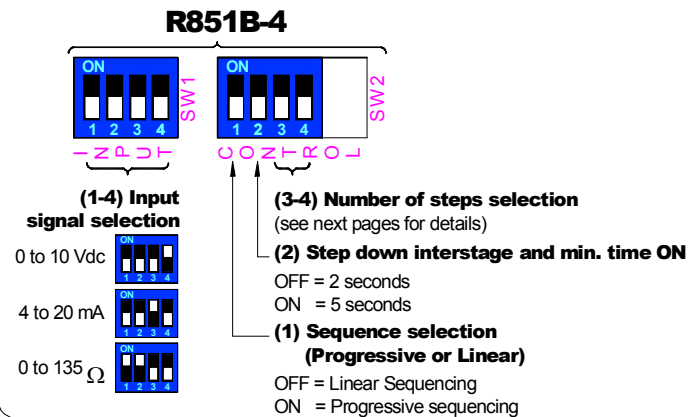
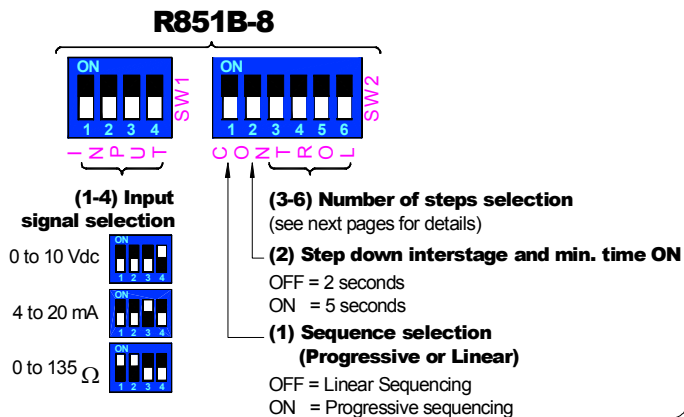

SPECIFICATIONS

Operating conditions: 0°C to 80°C (32°F to 176°F)
0 % to 95 % R.H. non-condensing

Relay outputs: **Pilot duty:**
- 24 - 120 Vac – 720 VA
- 240 Vac – 690 VA

Motor load:
- 120 Vac – 1 HP
- 240 Vac – 2 HP

Vernier stage: 0 to 10 Vdc, 5 mA max.

Input impedance: 0 to 10 Vdc into 10 KΩ minimum

Power supply: 24 Vac -15%, +10% 50/60 Hz; up to 18 VA
Use a Class 1 (properly fused) or Class 2, CSA or UL recognized transformer for power supply & relay outputs.

UL recognized: File # E212649

Specifications and equipment are subject to change without prior notice.

OVERRIDE TEST BUTTON

The override test button can be used to by-pass the interstage delay and bring on all stage at one time. This simplifies the verification of configured maximum number of stage. A status led per step will come on for each of the configured stage.

Input Signal Switch	Switch #1	Switch #2	Switch #3	Switch #4
0 to 10 Vdc control signal (2 to 10 Vdc control range)	Off	Off	Off	On
4 to 20 mA control signal	Off	Off	On	Off
0 to 135 Ω control signal	On	On	Off	Off

If a slave unit is used, wire the control signal input to the master unit only

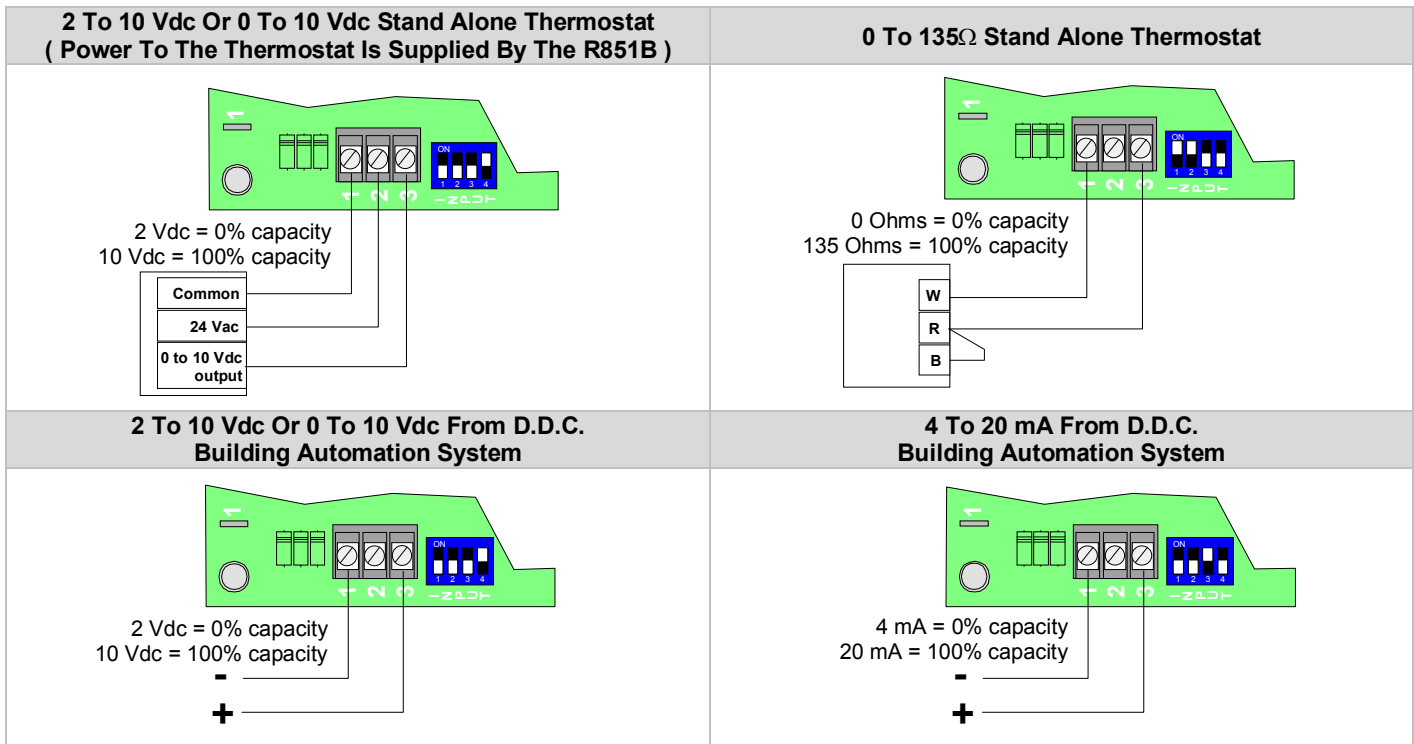

24 VAC POWER & RELAY OUTPUT WIRING

The wiring diagrams are for the R851B-8 models with 8 outputs. The wiring for the R851B-4 is the same except that the unit only has 4 outputs.

Terminals

- Screw terminal & connector #1 Common
- Screw terminal & connector #2 24 Vac
- Screw terminal & connector #3 Control Signal input

- It is not necessary to ground any leg of the transformer to earth with the controller card.
- The controller uses internally a half wave rectifier bridge. On 0 to 10 Vdc control signal, the reference of the control signal is the Common of the power supply of the SCR controller card.
- Use a Class 1 (properly fused) or Class 2, CSA or UL recognized transformer.

4 STAGE APPLICATION

R851B-4

Number of stage	R851B-4 Control Switch	
	Switch #3	Switch #4
1	Off	Off
2	On	Off
3	Off	On
4	On	On

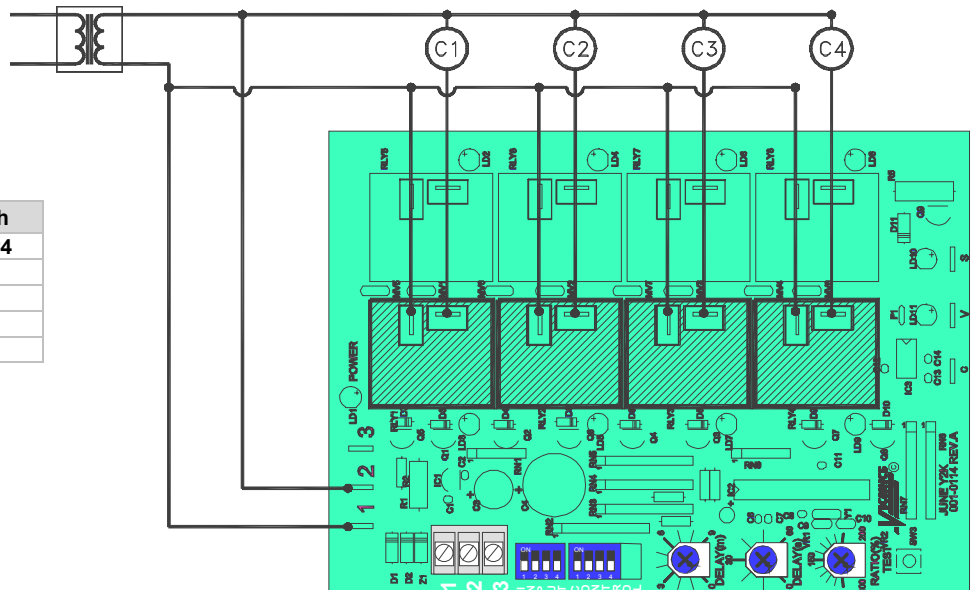

8 STAGE APPLICATION

R851B-8

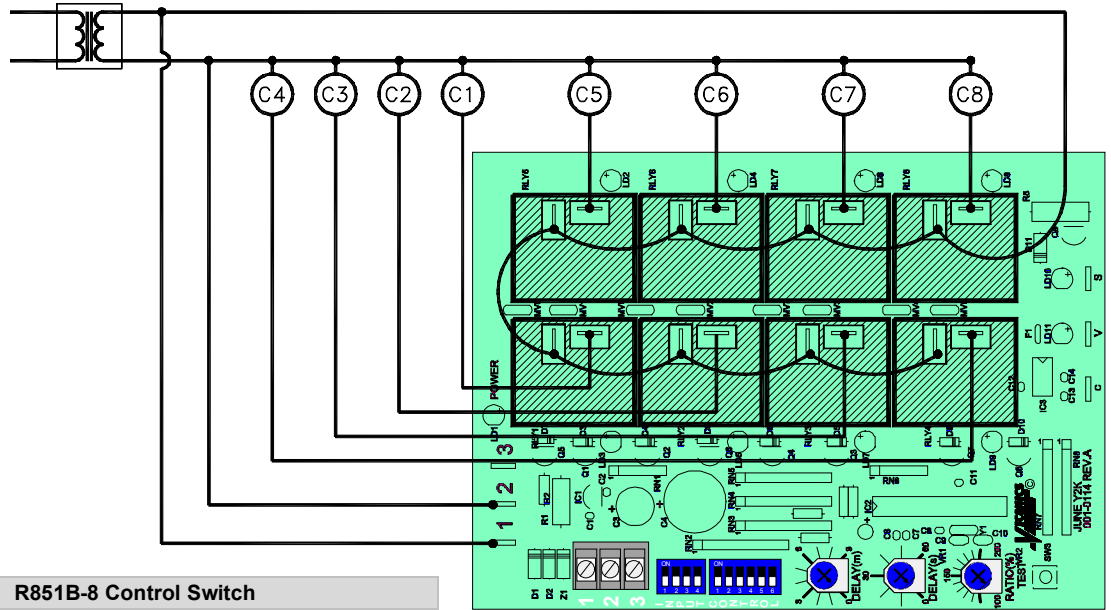

Number of stage	R851B-8 Control Switch			
	Switch #3	Switch #4	Switch #5	Switch #6
1	Off	Off	Off	Off
2	On	Off	Off	Off
3	Off	On	Off	Off
4	On	On	Off	Off
5	Off	Off	On	Off
6	On	Off	On	Off
7	Off	On	On	Off
8	On	On	On	Off

12 STAGE APPLICATION

(R851B-8 MASTER UNIT, R851B-4 SLAVE UNIT)

(See also slave application section at the end)

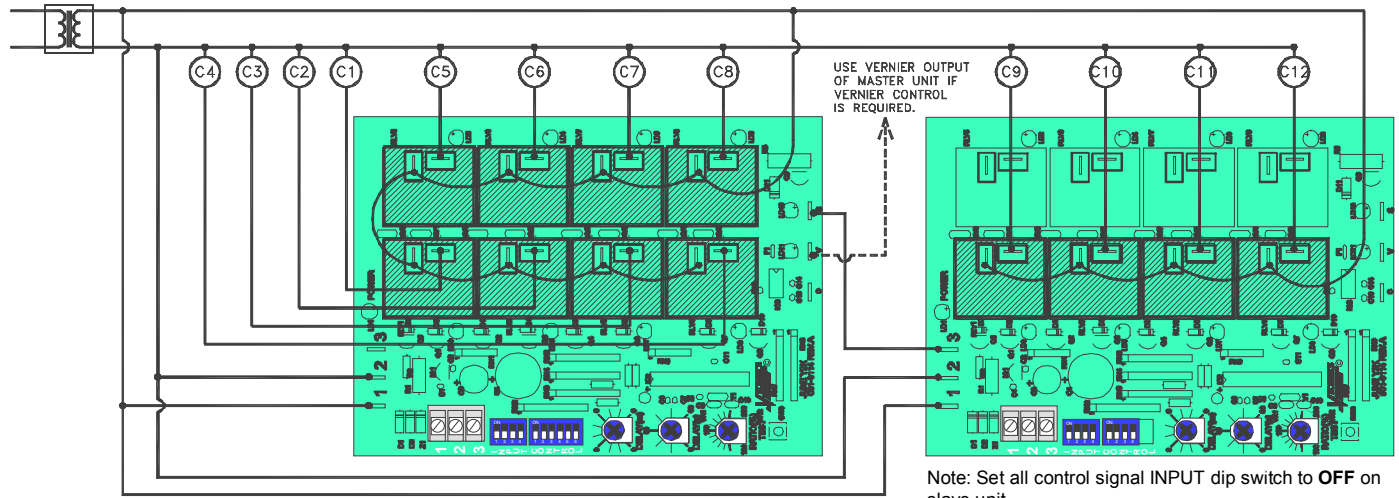

Number of stage	R851B-8 Master Unit Control Switch			
	Switch #3	Switch #4	Switch #5	Switch #6
9	Off	Off	Off	On
10	On	Off	Off	On
11	Off	On	Off	On
12	On	On	Off	On

R851B-4 Slave Unit	
Switch #3	Switch #4
Off	Off
On	Off
Off	On
On	On

The intensity of the yellow status LED on the master unit is proportional to the slave output.

16 STAGE APPLICATION

(R851B-8 MASTER UNIT, R851B-8 SLAVE UNIT)

(See also slave application section at the end)

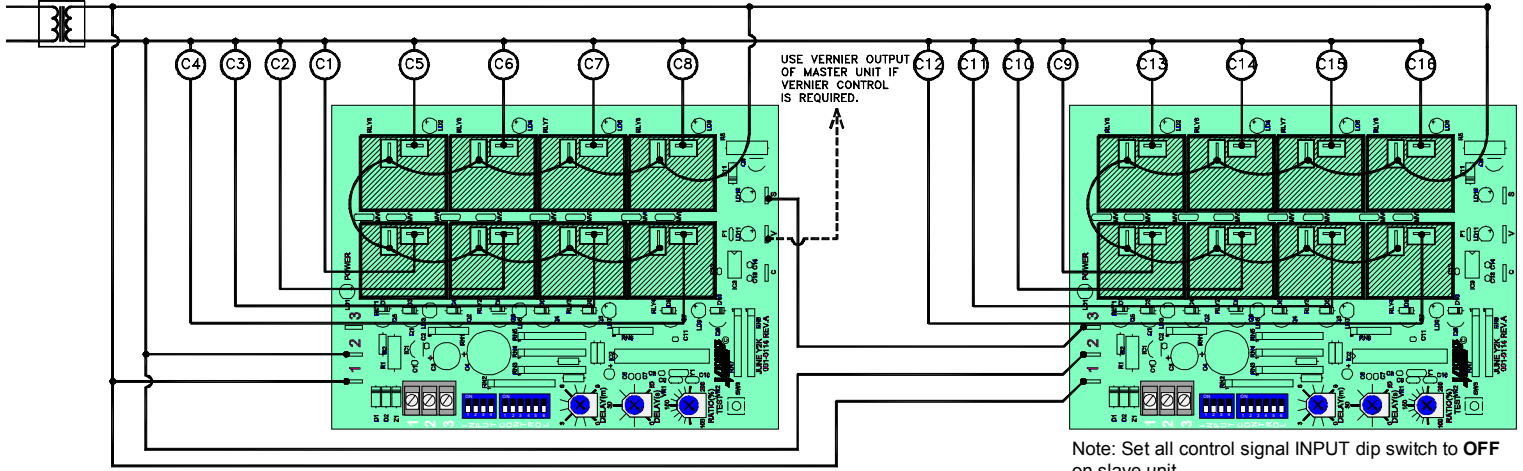

Note: Set all control signal INPUT dip switch to OFF on slave unit.

Number of stage
9
10
11
12
13
14
15
16

R851B-8 Master Unit Control Switch				
Switch #3	Switch #4	Switch #5	Switch #6	
Off	Off	Off	On	
On	Off	Off	On	
Off	On	Off	On	
On	On	Off	On	
Off	Off	On	On	
On	Off	On	On	
Off	On	On	On	
On	On	On	On	

R851B-8 Slave Unit Control Switch			
Switch #3	Switch #4	Switch #5	Switch #6
Off	Off	Off	Off
On	Off	Off	Off
Off	On	Off	Off
On	On	Off	Off
Off	Off	On	Off
On	Off	On	Off
Off	On	On	Off
On	On	On	Off

The intensity of the yellow status LED on the master unit is proportional to the slave output.

R851B DIMENSIONS & INSTALLATION

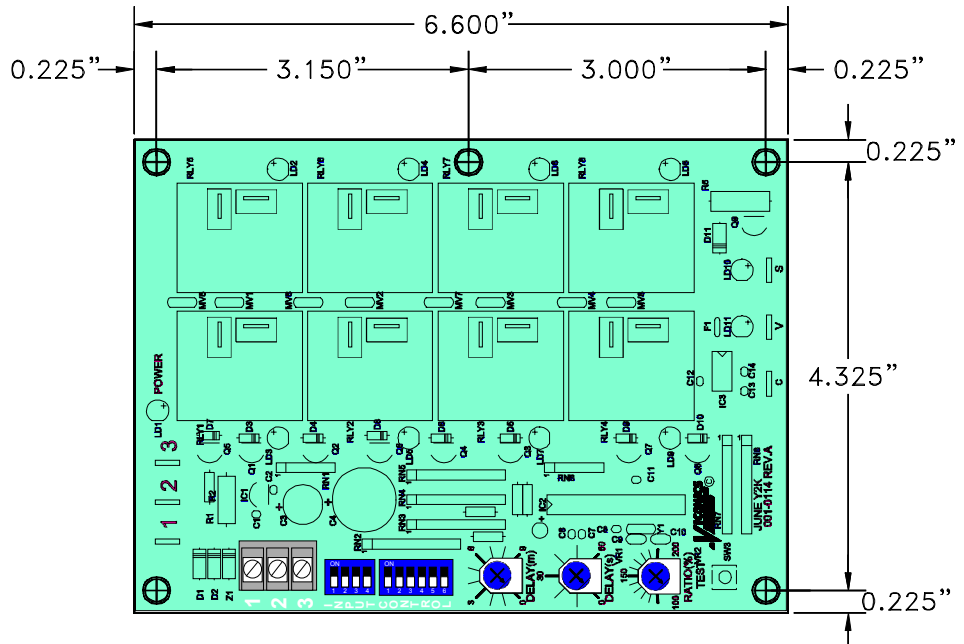

Install on the mounting plate on the electrical cabinet using five #6 pan head metal screw. Do not over torque the screws to prevent damage to the board. Specifications and equipment are subject to change without prior notice.

All R851B series controls are for use only as operating controls. Whenever a control failure could lead to personal injury and/or loss of property, it becomes the responsibility of the user to add safety devices and/or alarm system to protect against such catastrophic failures.

LINEAR / PROGRESSIVE

The R851B series features 2 different staging sequences:

- **LINEAR LAST IN FIRST OUT (CONTROL SWITCH #1 OFF, FACTORY DEFAULT)**

This is the regular mode, Stage #1 will always be the first to energize and the last stage to de-energize

- **PROGRESSIVE FIRST IN FIRST OUT (CONTROL SWITCH #1 ON)**

In this mode, the stages are rotated to ensure a more uniform wear of the contactors and elements. For example, on an increase in demand, stage 1 will be energized following by stage 2, etc. On a decrease in demand, stage 1 will de-energized first followed by stage 2, etc.

Please verify that if this mode is enabled, the manufactured product still complies with active codes and regulations.

VERNIER STAGE SELECTION AND WIRING

The Viconics R851B series step controller has an integrated vernier control output. This output will give a precise and full modulation of the load from 0 to 100% of the total capacity of the unit. If a master slave application is used, always connect the vernier output of the master unit.

RATIO SETTING (See also slave application section at the end)

First adjust the vernier stage ratio potentiometer. This will insure a smooth capacity rise of the total load.

Example 1:

The total unit has 100 kW divided in 10 equal stage of 10 kW.

If only 10 kW is used as the modulating stage, then the heater would have 9 on/off mechanical stage plus one modulating stage. This modulating stage has the same value as all the other stage. **Adjust the vernier stage ratio potentiometer to 100%.**

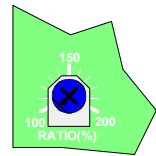

Example 2:

The total unit still has 100 kW divided in 10 equal stage of 10 kW.

If 20 kW are used as the modulating stage, then the heater would have 8 on/off mechanical stage plus one modulating stage. The modulating stage has twice the value as all the other stage. **Adjust the vernier stage ratio potentiometer to 200%.**

ADJUSTMENTS

Functions of the units can be configured with six dip switch and 2 potentiometers.

	<p>Step up interstage delay potentiometers setting</p> <ul style="list-style-type: none"> ▪ 2 potentiometers are used to adjust the interstage delay from 0 seconds up to 10 minutes. ▪ The value selected by both potentiometers will add up for the total step up interstage delay. ▪ This delay is the minimum time delay between each step activation when the control signal rises
<p>Control switch S2</p>	<p>Step down & minimum ON time setting (Control switch S2) Control switch S2 Off = 2 seconds On = 5 seconds</p> <ul style="list-style-type: none"> ▪ This delay acts as a minimum ON time when each step is activated ▪ The delay is also the step down interstage delay when the control signal drops

VERNIER STAGE WIRING

0 to 10 Vdc analog output to activate R820 SCR power controller

The intensity of the green status LED on the master unit is proportional to vernier output

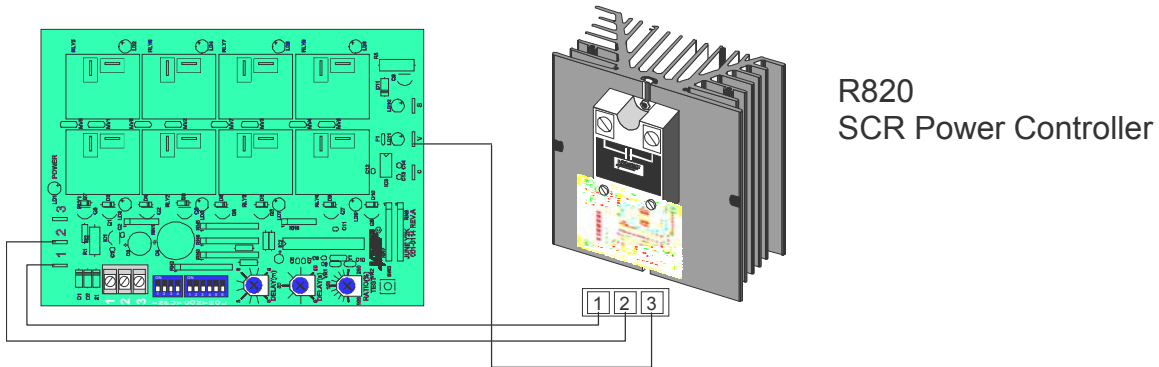

SLAVE APPLICATION SECTION

When using a unit for slave applications, it is important that the proper adjustments & setting be made to the unit for proper operation of the system.

The yellow LED near the vernier output connector is proportional to the vernier output of the master unit (0 to 5 Vdc).

On the slave unit:

- Set vernier ratio potentiometer to 100%
- Set interstage delay potentiometers & S2 switch to the same value as the master unit
- Set all control signal **INPUT** dip switch on the slave unit to **OFF**

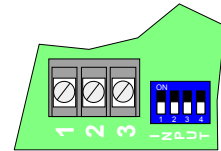

TEST MODE BUTTON

The test mode button can be used to verify if the number of stage have been configured properly.

1. Press and hold the button for 3 to 4 seconds.
2. If a slave unit is used, press & hold the 2 units button simultaneously
3. All the selected stage will come on, one after the other until all selected number of stage are all on.
4. There is a delay of approximately 5 second between each step activation.
5. When all selected stage are on, they will stay on for approximately 30 seconds before shutting down.

Powering up the R851B controller while holding down the test button will by-pass the interstage delay for 10 minutes. During that period, the unit will respond to a changing signal input very rapidly. Also hold down slave test button on start-up if a slave unit is used. After that 10 minute period, the unit will function normally with the interstage delays active