

# A.O. SMITH

---

## Century® Industrial Motors General Purpose Squirrel Cage Motors Drip-Proof Horizontal Frames 180 through 440 Bulletin C317

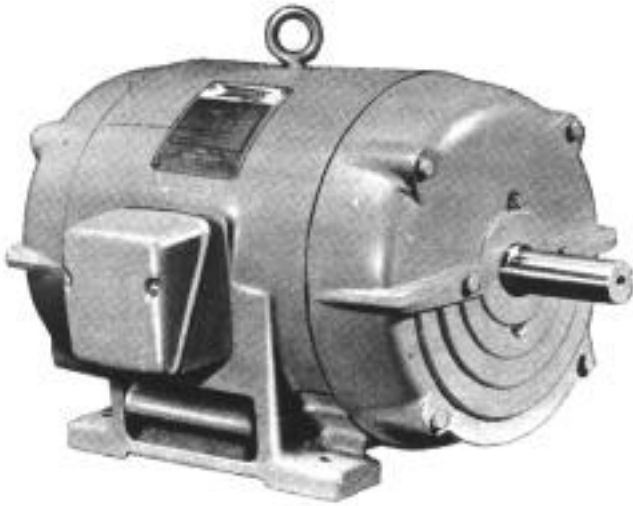

### RECEIPT OF SHIPMENT

When your equipment arrives, it should be checked immediately to see that all components have been received and that there is no evidence of damage in shipment.

In the event the complete assembly has not been received, or arrives in a damaged condition you should without delay notify the carrier who handled the shipment and the nearest A.O. Smith Authorized Service Center.

### STORAGE

If the equipment is not put into immediate use it should be stored in a clean, dry location. For long periods of storage, especially where moisture or dust is prevalent, the equipment should be covered to protect it from corrosion.

### LOCATION

In selecting a location for the unit, first consideration should be given to ventilation. It should be far enough from walls or other objects to permit a free passage of air.

The motor should never be placed in a room with a hazardous process, or where flammable gases or combustible material may be present unless it is specifically designed for this type of service.

### MOUNTING

The motor should be securely mounted on a bed plate, base or platform that is rigid enough to prevent any vibration of the unit and also prevent transfer of vibration to the unit. The base must not impose bending or twisting strains on the housing.

When mounting, we recommend the use of slotted shims as it may be necessary to remove or add shims when aligning shafts. The use of proper shims inserted under each mounting foot will prevent distortion of the housing when the mounting bolts are secured. The following procedure is recommended when mounting the motor.

1. Add shims under the lowest mounting foot and tighten mounting foot bolt.
2. Insert feeler gauges under the other mounting feet to determine amount of shims required.
3. Insert required shims under each mounting foot and tighten mounting bolts.
4. Use a small number of thick shims rather than a large number of thin shims.
5. Measure the alignment.

### INSTALLING COUPLING AND SHEAVES

The flexible coupling or sheave should be heated in oil before installation and slid into position on the shaft or installed with a pushing device.

**WARNING: DO NOT DRIVE OR FORCE COUPLINGS OR SHEAVES ONTO THE SHAFT. DAMAGE TO BEARINGS MAY RESULT. REFER TO THE COUPLING MANUFACTURER'S INSTRUCTIONS FOR THE PROPER INSTALLATION PROCEDURE.**

**ONE SOURCE...  
MANY POWERFUL SOLUTIONS.**

## ALIGNMENT – Direct Connected

ANGULAR MISALIGNMENT and RUN-OUT between direct connected shafts will cause increased bearing loads and vibration even when the connection is made by means of a flexible coupling.

To check for ANGULAR MISALIGNMENT, clamp the dial indicator to one coupling hub and place the finger, or button of the indicator against the finished face of the other hub as shown in the diagram below.

Rotate both shafts simultaneously, keeping the indicator button at the ref-

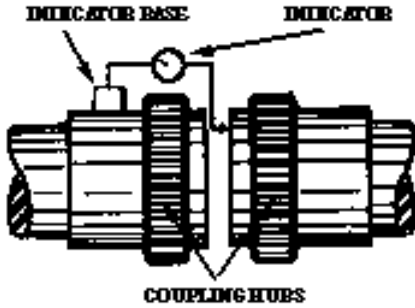

**Checking for Angular Misalignment**

erence mark on the coupling hub, and note the reading on the indicator dial at each one-quarter revolution.

ANGULAR MISALIGNMENT OF THE SHAFTS MUST NOT EXCEED A TOTAL INDICATOR READING OF .002 INCH FOR EACH INCH OF DIAMETER OF THE COUPLING HUB.

After the shafts have been checked for angular misalignment and are parallel within the limits specified in the preceding paragraph, check the shaft for RUN-OUT to assure concentricity of the shafts. Clamp the indicator to one coupling hub and place the indicator button on the machined diameter of the other hub as shown in the diagram below.

Rotate both shafts simultaneously, keeping the indicator button at the ref-

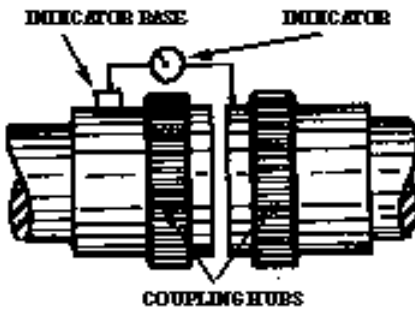

**Checking RUN-OUT of Directly Connected Shafts**

erence mark on the hub and note the reading on the indicator dial at each one-quarter revolution.

TOTAL RUN-OUT BETWEEN THE HUBS SHOULD NOT EXCEED .002 INCH.

## ALIGNMENT – Belted

Aligning a belted drive is much simpler than aligning a direct coupled drive. To check alignment, place a straight edge across the faces of the driver and driven sheaves. If properly aligned, the straight edge will contact both sheave faces squarely. The figure below shows the correct alignment of sheaves.

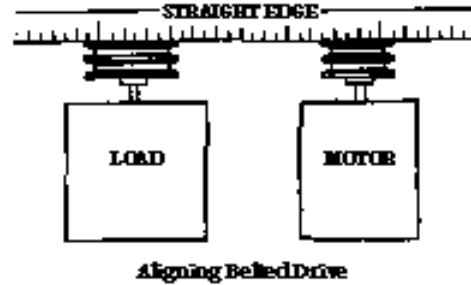

## TEMPERATURE

The ambient temperature of the air surrounding the motor should not exceed 40° C or 104° F unless the motor has been especially designed for high ambient temperature applications. The free flow of air around the motor should not be obstructed.

NEVER ATTEMPT TO MEASURE THE TEMPERATURE RISE OF A MOTOR BY HAND. Temperature rise MUST be measured by thermometer, resistance, or by imbedded detector or thermocouple.

## WIRING

Before starting the motor, check the nameplate to insure that the correct power supply (voltage frequency, and phase) is being used and that the motor is connected according to the connection diagram on the nameplate.

Be sure that the motor is connected for the correct rotation. Before connecting the driven machine, energize the motor and check the rotation.

## THERMOSTATS

Standard Century® Industrial motors are equipped with normally closed winding thermostats as required to comply with Underwriters Laboratories regulations on motor surface temperature. Thermostats are located in the winding, and the leads are marked X1, X2. The leads are to be connected in the control circuit so that when the thermoguard is activated the power source to the motor will be disconnected. Class I Group D units do not require thermostats.

## OPERATION

Alternating current motors shall operate successfully at rated load and frequency with voltages not more than 10% above or below nameplate ratings. Motors shall operate successfully at rated load and voltage with frequency variations not more than 5% above or below the rated frequency. Motors shall also operate successfully at rated loads with combined variations in voltage and frequency not more than 10% above or below the rated voltage and frequency provided the frequency variation does not exceed 5%. Motors operated with the above listed conditions are not necessarily in accordance with the guarantees for standard conditions.

## REGREASING— Lubrication for motors with Grease Fittings

Under normal operating conditions, it is only necessary to regrease a ball bearing motor every two to six years, depending upon the motor speed and operating conditions. A sound greasing procedure should be followed when regreasing a motor for it has been determined that THE GREATEST CAUSE OF BEARING FAILURE IS OVER GREASING RATHER THAN UNDER GREASING.

When regreasing, the following steps should be followed:

1. Clean the exterior of the motor.
2. Remove both the grease plug and relief plug (if supplied).
3. If grease has hardened, run a rod or wire a short distance into chamber to break grease. In severe conditions, run motor until bearing chamber becomes heated.
4. Regrease motor with low pressure grease gun.
5. For optimum operation, the bearing chamber should be three-quarters full of grease.
6. Operate motor for minimum of one hour.
7. Replace grease plugs.

NOTE: If the bearings are rough, the motor should be disassembled and the bearings replaced. Repack the bearings and bearing chamber with enough grease so that the bearing chamber of the assembled motor will be approximately three-quarters full.

## LUBRICATION FOR MOTORS WITHOUT GREASE FITTINGS

Bearings are factory lubricated for normal life. In the case of double shielded bearing the grease provided is that which is in the bearing.

When regreasing, the following steps should be taken.

1. Remove bearing brackets.
2. If original bearing is to be relubricated, remove shield opposite rotor. Do not replace. Flush old grease from bearing with suitable solvent. Lubricate bearing and add additional grease to bearing chamber. Chamber should be three-quarters full of grease. (An alternate method is to replace old bearing with new double shield prelubricated bearing.)
3. Bearing to be lubricated with recommended grease.
4. Reassemble motor.

## RECOMMENDED BALL BEARING GREASES FOR NORMAL CONDITIONS\*

It is recommended that these greases or their equivalent be used in Century® Industrial motors.

\*NORMAL conditions are considered to include most ambient atmospheres and operation requirements. SEVERE conditions include the following:

- Extreme dust, dirt or other atmospheric contaminants.
- Direct exposure to moisture beyond normal atmospheric humidity.
- Shock, vibration or other loading beyond rated.
- Extremes of operation cycle such as long shutdown, frequent starting or reversing.

For lubrication recommendations covering above SEVERE conditions refer to special lube instructions furnished, or consult nearest A.O. Smith motor representative.

Company	NORMAL Amb. Temp. -20° F to 105° F	HIGH Amb. Temp 0° to 150° F
Chevron	SRI No. 2	SRI No. 2
Shell Oil Co.	Dolium R	Dolium R
Shell Oil Co.	Darina No. 2	Darina No. 2
Texaco	Premium RB	Premium RB
Texaco	AFB No. 2	AFB No. 2
Mobil	Mobilux No. 2	Mobiltemp SHC 32
Mobil	Mobilgrease 28	Mobilgrease 28
Gulf Oil	Gulf Crown No. 2	Gulf Crown No. 2
Exxon	Unirex N2	Unirex N2

## RECOMMENDED REGREASING SCHEDULE FOR BALL BEARINGS\*\*

Motor Speed	Approximate Hours of Operation	
	Normal Conditions	Severe Conditions
1200 & Below	6000-8000	3000-4000
1800	3000-4000	1400-2000
3600	1500-2000	750-1000

\*\*For roller bearings 1800 RPM and below, and in the absence of other instructions, it is recommended that the hours indicated in the table to the left be reduced to 1/3 listed values.

# Century® Industrial Motor

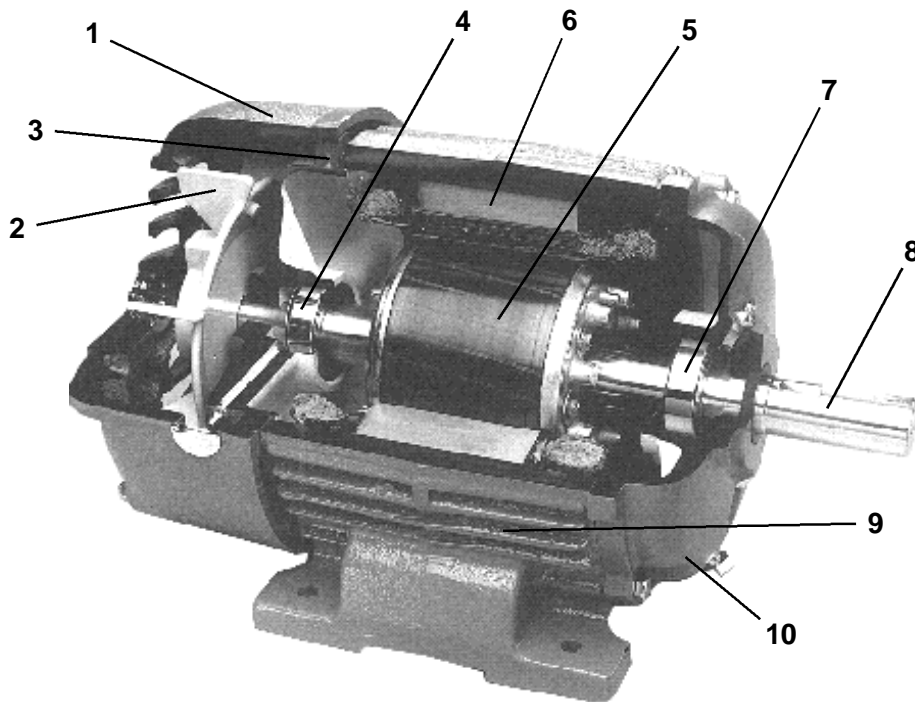

- |               |                  |                  |
|---------------|------------------|------------------|
| 1. Fan Guard  | 4. Front Bearing | 7. Back Bearing  |
| 2. Fan        | 5. Rotor         | 8. Shaft         |
| 3. Front Head | 6. Stator        | 9. Housing       |
|               |                  | 10. Back Bracket |

NOTE: Special motors such as flange mounted motors and/or motors with special shafts may not follow the above parts list exactly. However, construction details will be similar to the above and parts lists are available upon request.

When ordering repair parts, always give the serial number being serviced, the part name and number and furnish complete nameplate data.

---

**A.O.SMITH**  
ELECTRICAL PRODUCTS  
COMPANY

531 Nourth Fourth Street  
Tipp City, OH 45371  
(937) 667-2431  
Fax: (937) 667-5030  
[www.aosmithmotors.com](http://www.aosmithmotors.com)