

BELT DRIVE FORWARD CURVED BLOWERS

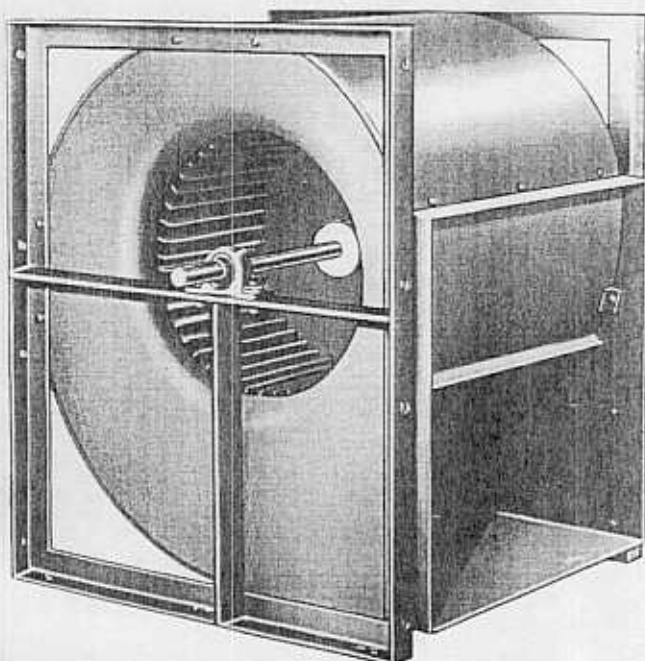
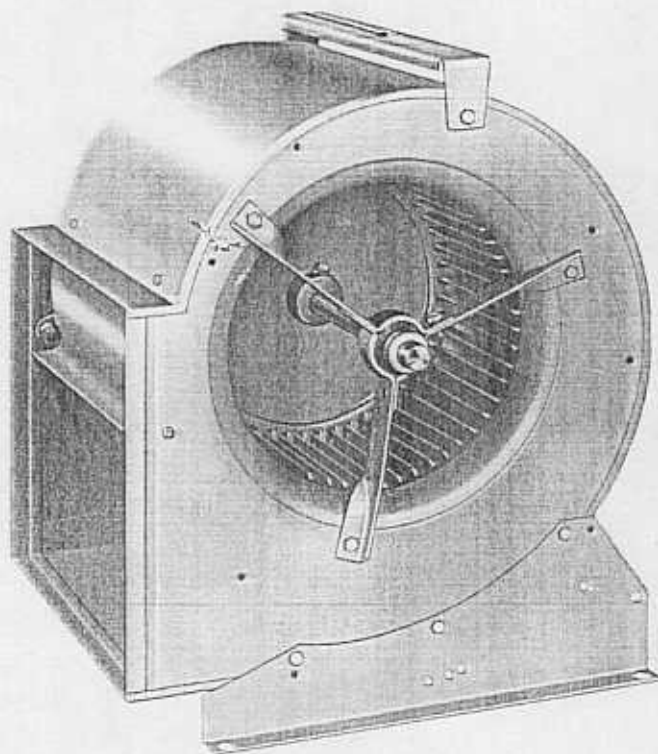

CONTENTS

<u>CONTENTS</u>	<u>PAGE</u>
"G" Series	2, 3
"800" Series	4
"900" Series	5
"800" - "900" Dimensions	6, 7
Performance Data	8, 9, 10, 11
Wheels & Housings	12

"G" SERIES DOUBLE INLET BELT DRIVE BLOWERS

STANDARD FEATURES

A Standard "G" series blower is often selected for most applications due to the availability and the flexibility of the product. Capacity range from 200 to 8000 CFM. Eleven standard models in full and partial widths.

Detachable base sides can be installed for upblast, downblast, top horizontal or bottom horizontal discharge positions. The motor mounting bracket can be installed to position the motor at several locations around the blower housing. Shaft extensions on both sides of the blower allow motor and drives to be mounted on either side of the blower.

WHEEL

- The blower wheel has an exclusive center disc which allows Delhi blowers to be used safely at speeds well above any normal requirement.

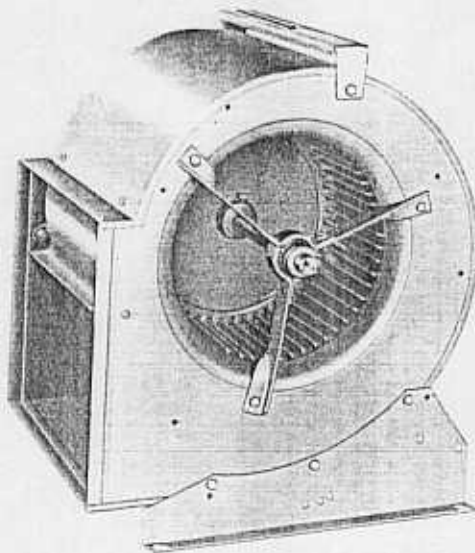

HOUSING

- Delhi blower housings have extruded holes to give greater holding capacity for mounting base sides and motor bracket.

FINISH

- Blower housing is finished in high gloss, green baked enamel paint.
- Matte finish zinc coated wheel and cut-off baffle.

NOMENCLATURE:

e.g. G 10 8

SERIES
NOMINAL WHEEL DIA. IN.
NOMINAL WHEEL WIDTH IN.
(SAME AS WHEEL DIA. WHEN OMITTED)

SHAFTS

- Shafts are ground to close tolerance. Finish is carefully controlled to ensure quiet, trouble free operation.

BEARINGS

- Permanently lubricated sleeve bearings are standard for clean air applications:
 - up to 3/4 HP
 - within +30 deg. to +120 deg. F operating temperature
 - less than 1000 RPM
- Ball bearings with a sealed lifetime supply of lubricant are optional. Suitable for operation in ambient temperatures of -65 to +250 deg. F.
- Both sleeve and ball bearings are mounted in resilient neoprene rings.

MOTOR BRACKETS

- Motor mounting bracket and all necessary mounting and belt tension adjusting hardware is included with each blower.

CUSTOM BLOWERS

Custom blowers are suitable for specific or unique requirements - usually in quantity and with longer lead times. Some typical features are listed below.

HOUSINGS

- Outlet flanges.
- Special holes.
- Custom base sides.
- Tight and narrow.

SHAFTS

- Optional size - diameter and length.
- Keyways and keys.
- Flats.

BEARING BRACKETS

- Heavy duty bearing brackets.
- Oversize bearing cups (for 1" and 1-3/16" shafts).

WHEELS, HOUSINGS & CUT-OFF

- Blower housing, cut-off baffle and wheel only. For use with customer supplied shaft and bearings.

WHEEL

- Custom bore sizes (see p. 12).
- Extra set screw at 90 degrees.
- Keywayed hub.

TWIN UNITS

- Two blowers on a common shaft with 2 or more tie bars joining the blower housings and using 2 or more bearings.
- Spacing between blowers as required.

MOTOR BRACKETS

- Extra duty motor mounting brackets.
- Special motor adjusting hardware.

For complete engineering and application details request Delhi's "OEM" Application Guidelines Manual.

Component Details

G Series Belt Drive



The **Component Limits** page lists component limit guidelines to assist in applying 'G' blowers to various 'duties'.

It is recommended that the Delair computer program be used to quickly present information from which a blower selection can be made. After selecting the blower model check the component limit guidelines at the speed and horsepower determined.

MOTOR MOUNTING BRACKETS



The first limiting component will usually be the motor mounting bracket. The **Component Limits** page shows heavy duty options

available, and they are illustrated on the **Motor Mounting Brackets** page. If none of these will handle the application horsepower, consider the option of mounting the motor on a separate base. Alternatively, it may be feasible to select a Delhi series 800 or 900 unit which would allow the motor to be mounted on the blower frame.

To avoid shipping damage, motors exceeding 2 HP should not be mounted to the blower housing motor bracket prior to shipping, unless additional shipping support and blower protection is furnished.

BLOWER BASE SIDES (FEET)



If the installed horsepower will exceed the 3 HP limit of the Delhi base sides (feet), it will be necessary to use some other means to attach the blower, or select

a Delhi 800 or 900 series unit.

SHAFT AND BEARINGS



The Maximum HP shown for a particular shaft size is based on a minimum L10 life of 30,000 hours. (L50 = 150,000 hours). For further discussion see "Bearings" elsewhere in this catalogue.

If the application requires a speed outside the RPM range or above the maximum HP shown on the **Component Limits** page, a larger shaft and bearings will be required. A more accurate determination of the correct size can be made with the **Shaft Size and Bearing Life** program, a sub-program under the "Utilities" menu item in Delair. Often it is best to select a Delhi 900 series unit which will meet the requirements. Contact your Delhi representative or the factory order desk to confirm your selection if required.

BEARING BRACKETS

The **Component Limits** page shows available bearing brackets and they are illustrated on the **Bearing Brackets** page.



If no bearing bracket meets the needs, consider a Delhi 900 series assembly which uses pillow block bearings with 'T' bar supports.

WHEELS



Maximum wheel speeds shown on the **Component Limits** page show that all sizes of G Series wheels may be used at conditions described in the AMCA Class II definition. Stock G Series units may not have adequate shaft and bearing size to operate in the upper range. The heavy duty construction of a Delhi series 900 unit with the appropriate shaft will normally be required to safely allow the wheel to be driven up to the Class II limit.

Contact Delhi to review your selections and to review the limitations which may apply to your application. Delhi will be able to suggest an alternate construction which will withstand the conditions of your application

If you require a Delhi G series twin assembly, contact Delhi for shaft, bearings, support recommendations based on your proposed application conditions.

HUB-TO-SHAFT

Delhi G series blower wheels have single center disks and hubs up through G10 sizes. Larger sizes have double center disks and hubs. One cup point set screw per hub is furnished. A second set screw per hub can be furnished for unusual applications.

1-3/16" shafts and larger are keyed to the wheel hubs.

SHAFT-TO-PULLEY

Stock blowers are fitted with double extension shafts to allow installation of the blower pulley on either side. For pulley mounting, sleeve bearing units have milled flats while stock ball bearing units have keyways.

"G" SERIES DOUBLE INLET BELT DRIVE BLOWERS

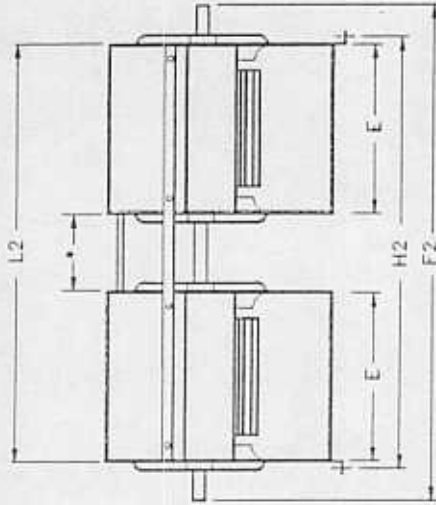
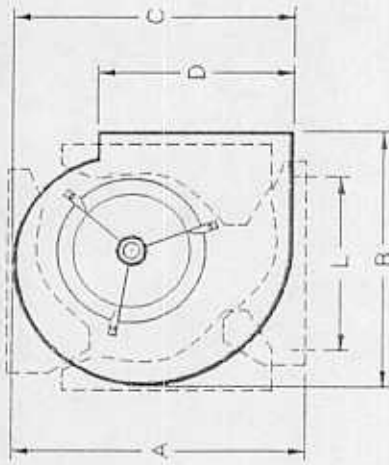
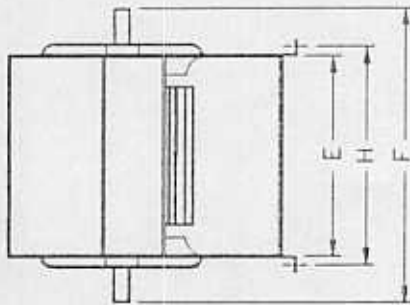

"G" SERIES TWIN UNITS

* SPACING WILL DETERMINE "L2" AND "F2" DIMENSIONS

DIMENSIONS (inches)

MODEL	A	B	C	D	E	F	H	L	SHAFT DIAMETER	WHEEL DIAMETER	WHEEL WIDTH	WT. (LBS.)
G7-5	14-5/16	12-5/16	12-11/16	8-1/4	6-7/8	10-3/8	7-7/8	9-5/8	3/4	8-1/16	4-15/16	15
G7	14-5/16	12-5/16	12-11/16	8-1/4	9-3/16	12-11/16	10-3/16	9-5/8	3/4	8-1/16	7-3/16	17
G9-7	16-15/16	15-1/16	15-9/16	10-1/4	9-3/16	12-11/16	10-3/16	11-3/4	3/4	10-1/4	7-3/16	21
G9	16-15/16	15-1/16	15-9/16	10-1/4	11-13/16	15-5/16	12-13/16	11-3/4	3/4	10-1/4	9-9/16	23
G10-8	19	16-3/4	17-3/8	11-3/8	10-1/2	14	11-1/2	13-3/8	3/4	11-1/8	8-1/16	25
G10	19	16-3/4	17-3/8	11-3/8	13-1/8	16-5/8	14-1/8	13-3/8	3/4	11-9/16	10-13/16	28
G12-9	22-1/8	19-1/2	20-5/8	13-7/16	12-1/4	15-3/4	13-1/4	16-1/8	3/4	12-7/8	9-9/16	32
G12	22-1/8	19-1/2	20-5/8	13-7/16	15-5/8	19-1/8	16-5/8	16-1/8	3/4 or 1	12-7/8	12-13/16	38
G15-12	25-3/4	22-11/16	24-1/4	15-7/8	14-11/16	20	15-11/16	19-1/2	1	15-1/2	10-13/16	52
G15	25-3/4	22-11/16	24-1/4	15-7/8	18-5/8	24	19-5/8	19-1/2	1	15-1/2	15-1/16	62
G18	30-1/2	27	29	18-7/8	21-7/8	29	22-7/8	24	1	18-1/2	18-1/2	99

REFER TO PAGES 8 TO 11 FOR PERFORMANCE DATA.

DELHI 900 SERIES DOUBLE WIDTH, DOUBLE INLET, HEAVY DUTY BLOWERS

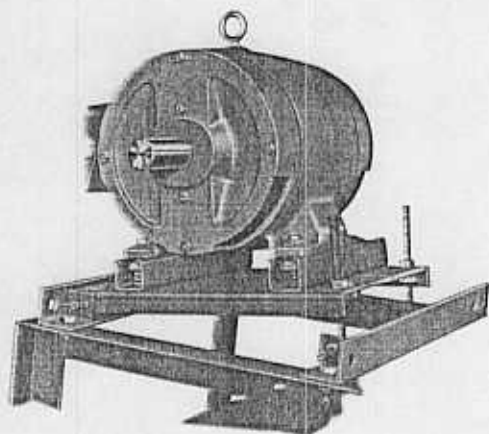

OPTIONAL
1 TO 15 HP
MOTOR PLATFORM

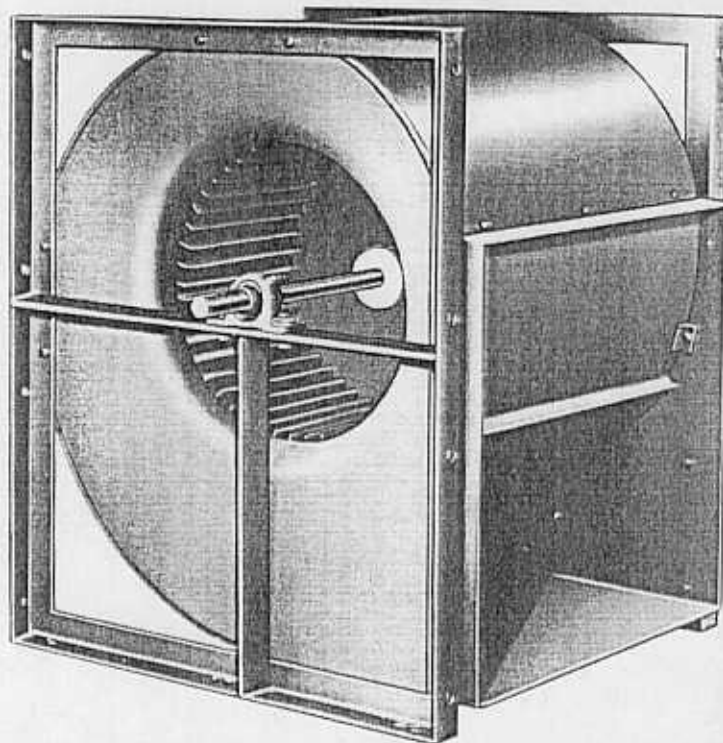

STANDARD FEATURES

- Single and twin assemblies.
- Delhi 'G' series matte finish zinc coated steel wheel in sizes 907 - 918 capable of running at AMCA Class II operating conditions with appropriate shaft and bearings..
- Delhi '900' riveted blade construction G90 zinc coated steel wheel in sizes 920 through 925, capable of running at AMCA Class II operating conditions with appropriate shaft and bearings..
- Cold rolled steel, high gloss green baked enamel paint finish housing in sizes 907 - 918.
- High gloss green high solids weather resistant air dry paint on G90 zinc coated steel housing in sizes 920 - 925.
- Welded angular steel blower frames with T bar supports under bearings when used in bottom horizontal discharge (BHD) mounting position. Suitable for top horizontal discharge (THD), upblast (UB) or downblast (DB) discharge position.
- Frames and bearing supports are carbon steel finished with a coat of high solids, weather resistant, green, air dry paint.
- Pre-lubricated cast iron pillow block ball bearings with grease fitting suitable for operating in ambient temperatures to -65 to +250 deg. F.
- Shaft extensions keywayed both ends. Shaft length provided for single or double groove pulleys.
- Corrosion inhibiting shaft coating.
- Units skidded for shipment..

OPTIONAL ACCESSORIES:

Models 907 to 915
Motor mounting bracket
with mounting and belt
tension adjusting hardware.

Models 912 to 925
1 to 15 HP motor platform
with mounting hardware.
20 to 50 HP motor platform
with mounting hardware.

SEE PAGES 6 & 7 FOR DIMENSIONS, PAGES 8 TO 11 FOR PERFORMANCE DATA.
FOR COMPLETE ENGINEERING AND APPLICATION DETAILS REQUEST DELHI'S "OEM" APPLICATION GUIDELINES MANUAL.

"800" & "900" SERIES SINGLE UNIT DIMENSIONS

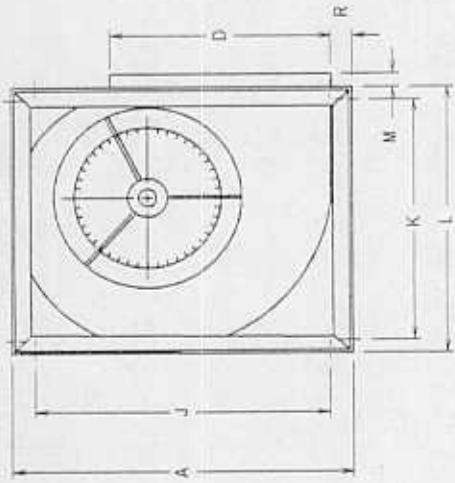

"800" SERIES

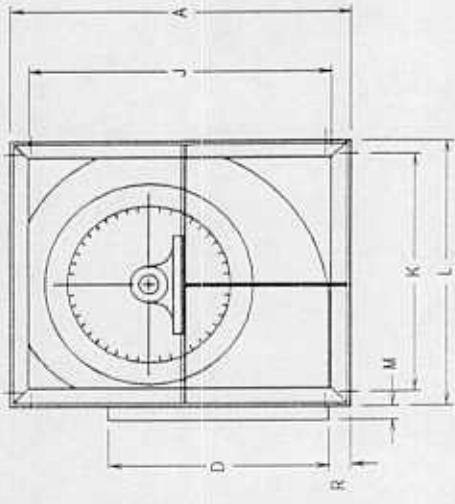

"900" SERIES

DIMENSIONS (Inches)

800 SERIES MODEL	SHAFT DIAMETER		A	D	E	F (SEE NOTE)	G	H	J	K	L	M	P	R	U	WHEEL DIAMETER	WHEEL WIDTH	900 SERIES WT. (LBS.)	800 SERIES WT. (LBS.)
	800 SERIES N	900 SERIES (SEE NOTE)																	
807		3/4	14-3/8	8-1/4	9-3/16	17-3/16	8-5/8	10-3/8	11-5/8	9	11-3/4	3/4	11-3/8	1-1/2	7/16 x 5/8	8-1/16	7-3/16	...	28
808		3/4	17-1/4	10-1/4	9-3/16	17-3/16	10-1/8	10-3/8	14-1/2	11-3/4	14-1/2	3/4	11-3/8	1-1/2	7/16 x 5/8	10-1/4	7-3/16	...	34
809		3/4	17-1/4	10-1/4	11-13/16	19-13/16	10-1/8	12-15/16	14-1/2	11-3/4	14-1/2	3/4	13-5/16	1-1/2	7/16 x 5/8	10-1/4	9-9/16	28	40
810-8		3/4	19-1/8	11-3/8	10-1/2	18-1/2	11-1/4	11-5/8	16-1/2	13-3/8	16-1/4	3/4	12-5/8	1-1/2	7/16 x 5/8	11-1/8	8-1/16	...	43
810		1	19-1/8	11-3/8	13-1/8	21-5/8	11-1/4	14-1/4	16-1/2	13-3/8	16-1/4	3/4	15-1/4	1-1/2	7/16 x 5/8	11-9/16	10-13/16	32	52
812-9		1	22-1/4	13-7/16	12-1/4	20-3/4	13	13-3/8	19-5/8	16-3/4	19	3/4	14-3/8	1-1/2	7/16 x 5/8	12-7/8	9-9/16	...	55
812		3/4	22-1/4	13-7/16	15-5/8	24-1/8	13	16-3/4	19-5/8	16-3/4	19	3/4	17-3/4	1-1/2	7/16 x 5/8	12-7/8	12-13/16	43	69
815-12		1	26	15-7/8	14-11/16	23-3/16	15-1/4	15-13/16	23-3/8	19-5/8	22-1/8	3/4	19-13/16	1-1/2	7/16 x 5/8	15-1/2	10-13/16	...	72
815		1	26	15-7/8	16-5/8	27-1/8	15-1/4	19-3/4	23-3/8	19-3/8	22-1/8	3/4	20-3/4	1-1/2	7/16 x 5/8	15-1/2	15-1/16	67	87
818		1	30-3/4	18-7/8	21-7/8	34	17-3/4	23-1/2	29	24-1/2	28-1/2	3/4	25	1-1/2	7/16 x 5/8	18-1/2	18-1/2	125	120
820		1-3/16	38	24-3/4	24-3/4	37-1/4	22-9/16	26-1/4	32-1/4	25-1/2	31-1/4	1-1/2	28-3/4	2	5/8	20-3/4	20-3/8	...	220
822		1-3/16	41-1/2	27-1/4	27-1/4	39-3/4	24-5/8	28-3/4	35-3/4	28-1/2	34-1/4	1-1/2	31-1/4	2	5/8	22-1/4	22-3/8	...	245
825		1-3/16	46-3/4	31-1/4	31-1/4	43-3/4	27-3/4	32-3/4	41	32-3/4	38-3/8	1-1/2	35-1/4	2	5/8	26-1/16	25-3/4	...	297

NOTE: "P" DIMENSION MAY VARY AMONG OPTIONAL SHAFT DIAMETERS. 900 SERIES SHOWN. STANDARD SHAFT SIZES SHOWN. LARGER DIAMETER SHAFTS AVAILABLE UP TO 2 1/4" ON 900 SERIES ONLY. ALL WHEELS CAN RUN SAFELY AT AMCA CLASS B OPERATING CONDITIONS WITH APPROPRIATE SHAFT AND BEARINGS.

METHODS FOR LOCKING THE INNER RING TO THE SHAFT

Eccentric Locking Collar

Ball bearings with eccentric locking collars are used on G Series and 800 Series. Additionally, many 900 Series units currently in service have an eccentric locking collar. Should replacement be needed it is important that the locking collar be installed correctly, as illustrated below, to avoid premature failure.

Note the cam-like contour of the inner race extension and of the collar.

When assembled and rotated the bearing inner race, the collar, and the shaft are firmly joined with a wide matting surface area.

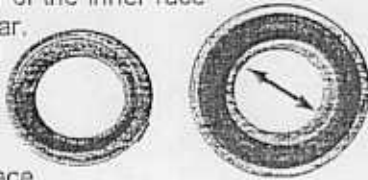

Setting the Collar:

Insert a punch in the hole provided and apply a solid tap in the direction of blower wheel rotation. Then firmly fasten the set screw in the collar to the shaft. (See torque specifications in this section)

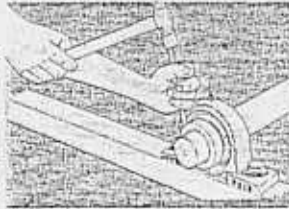

On start-up, ensure that the blower is not reverse rotated, which might loosen an eccentric style lock.

Double Set Screw Locking Collar

Ball bearings with double set screw locking collars are used on 900 Series. The set screws are separated by 120°. See torque settings elsewhere in this section.

If a bearing has failed, the shaft is typically damaged as well and must be replaced. If the shaft is not replaced, a double-set screw type bearing locking mechanism, less reliant on a smooth mating surface, is preferable to the eccentric lock type.

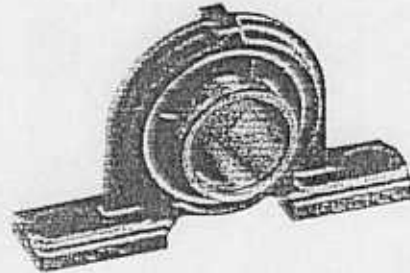

Note: The ductile iron pillow block shown is 20% stronger than traditional cast iron, despite a somewhat smaller profile.

BEARING LUBRICATION

No relubrication is the rule

A lithium based grease, suitable for long term use, is sealed in the bearing making relubrication unnecessary under most operating conditions.

Insert bearings are non-lubricatable. Pillow block bearings are equipped with a grease fitting for unusual operating conditions.

New bearings should never be greased as they contain the correct amount (about 1/3 to 1/2 full) of grease. *Over lubrication can result in reduced bearing life* due to internal temperature gradients reducing internal metal-to-metal clearances.

If lubrication is unavoidable...

Sometimes established maintenance procedures, engineering specifications, or harsh environments like dust, water or elevated temperatures mean relubrication will occur.

The best way to avoid overlubrication is to lubricate with extended lube lines, safely away from any moving

parts, while the blower is in operation which will expel any excess grease through the seals rather than permit the grease to fill the bearing cavity and cause damage. Warning labels should advise against lubricating without rotation.

If lube lines are not present, **disconnect and lock-out the power.** Remove the belt(s) and rotate the blower by hand while adding one or two shots from a grease gun.

Harsh Environment Lubrication Frequency

The list of variables involved in defining the need for lubrication are myriad, but some guidance is available. Rarely do blowers require lubrication at intervals less than 6 - 12 months. One to two shots from a grease gun is sufficient.

Type of Lubricant

Use lithium based lubricants such as ESSO - Beacon 325, Shell - Alvania Grease #3. Others, particularly with a non-lithium carrier for the lubricants, will likely react chemically reducing bearing life.

Bearing Torques

RECOMMENDED TORQUE FOR BOLTING BEARING TO FRAME OR PLATE

BEARING SIZE	NTN			SKF	
	BOLT SIZE	RECOMMENDED	MAXIMUM	BOLT SIZE	MAXIMUM
	S.A.E.	FT. LBS.	FT. LBS.	S.A.E.	FT. LBS.
3/4"	3/8"	20	20	3/8"	20
1"	3/8"	20	20	3/8"	20
1-3/16"	1/2"	55	55	1/2"	55
1-7/16"	1/2"	55	55	1/2"	55
1-11/16"	1/2"	55	55	1/2"	55
1-15/16"	5/8"	85	85	5/8"	85
2-3/16"	5/8"	85	85	5/8"	85
2-1/4"	5/8"	85	85	5/8"	85
2-7/16"	5/8"	85	85	5/8"	85
2-11/16"	3/4"	160	160	3/4"	160

RECOMMENDED TORQUE FOR BEARING SET SCREWS TO SHAFT Dual Set Screw Bearings

BEARING SIZE	NTN			SKF	
	SET SCREW	RECOMMENDED	MAXIMUM	SET SCREW	MAXIMUM
	SIZE	IN. LBS	IN. LBS	SIZE	IN. LBS.
3/4"	#10-32UNF	28	30	1/4-28UNF	87
1"	#10-32UNF	28	30	1/4-28UNF	87
1-3/16"	1/4-28UNF	37	39	5/16-24UNF	165
1-7/16"	1/4-28UNF	37	43	5/16-24UNF	165
1-11/16"	5/16-24UNF	58	60	5/16-24UNF	165
1-15/16"	5/16-24UNF	58	60	3/8-24UNF	290
2-3/16"	5/16-24UNF	83	86	3/8-24UNF	290
2-1/4"	3/8-24UNF	144	147	3/8-24UNF	290
2-7/16"	3/8-24UNF	144	147	3/8-24UNF	290
2-11/16"	3/8-24UNF	170	173	3/8-24UNF	290

Eccentric Locking Collar Bearings

BEARING SIZE	SET SCREW SIZE	TORQUE (IN. LBS)
3/4", 1"	1/4-28 UNF	65 +/- 5
1-3/16"	5/16-24 UNF	80 +/- 5
1-7/16"	3/8-24 UNF	100 +/- 5
1-11/16", 1-15/16"	3/8-24 UNF	130 +/- 5
2-1/4"	3/8-24 UNF	170 +/- 5

Belt Tensioning Guidelines

GENERAL

Overtensioning of belts can cause premature bearing failure, shorten belt life, and overload a motor that would otherwise be adequate.

Warning labels are very helpful in preventing adverse field adjustments to proper factory settings.

RESILIENT BASE MOTORS

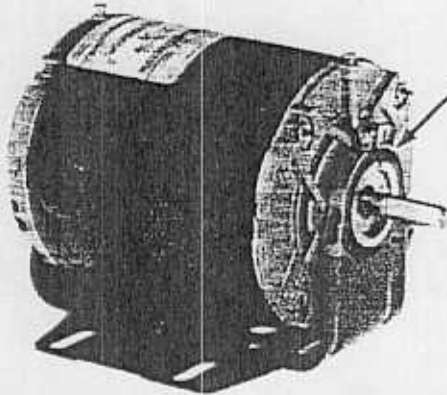

Resilient rings hold the motor at each end and adds some springiness to the drive assembly. These are found on many fractional HP motors.

With the belt grasped as shown, a total of 1" of deflection (1/2" on each side) should be easily obtained.

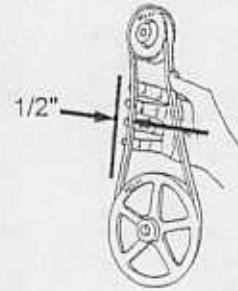

RIGID BASE MOTORS

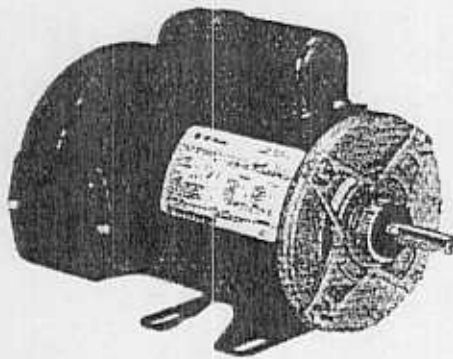

Good Method

Release the tension from the belt ensuring there is no slack. Measure the distance between shaft centers. Add 1% to the shaft center distance and adjust the shaft centers until that value is obtained.

Example: The untensioned shaft centers on a model 910 blower measure 12-9/16". Tensioned centers = $12\text{-}9/16 \times 1.01 = 12\text{-}11/16"$. (1/8" extension)

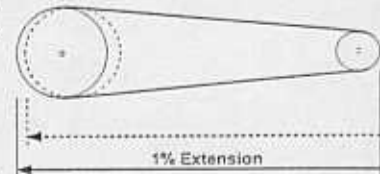

Better Method

Using a gauge, apply 4 lbs. of force to the center of the belt and adjust the tension until a deflection of 1/64" for every inch of shaft center distance is obtained.

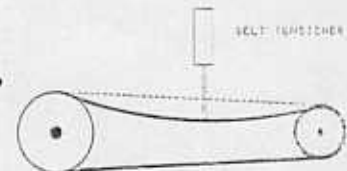

Perfect Method

Ideal belt tension is the lowest value under which belt slip will not occur at peak load conditions.