

MAKE-UP AIR ENGINEERING MANUAL

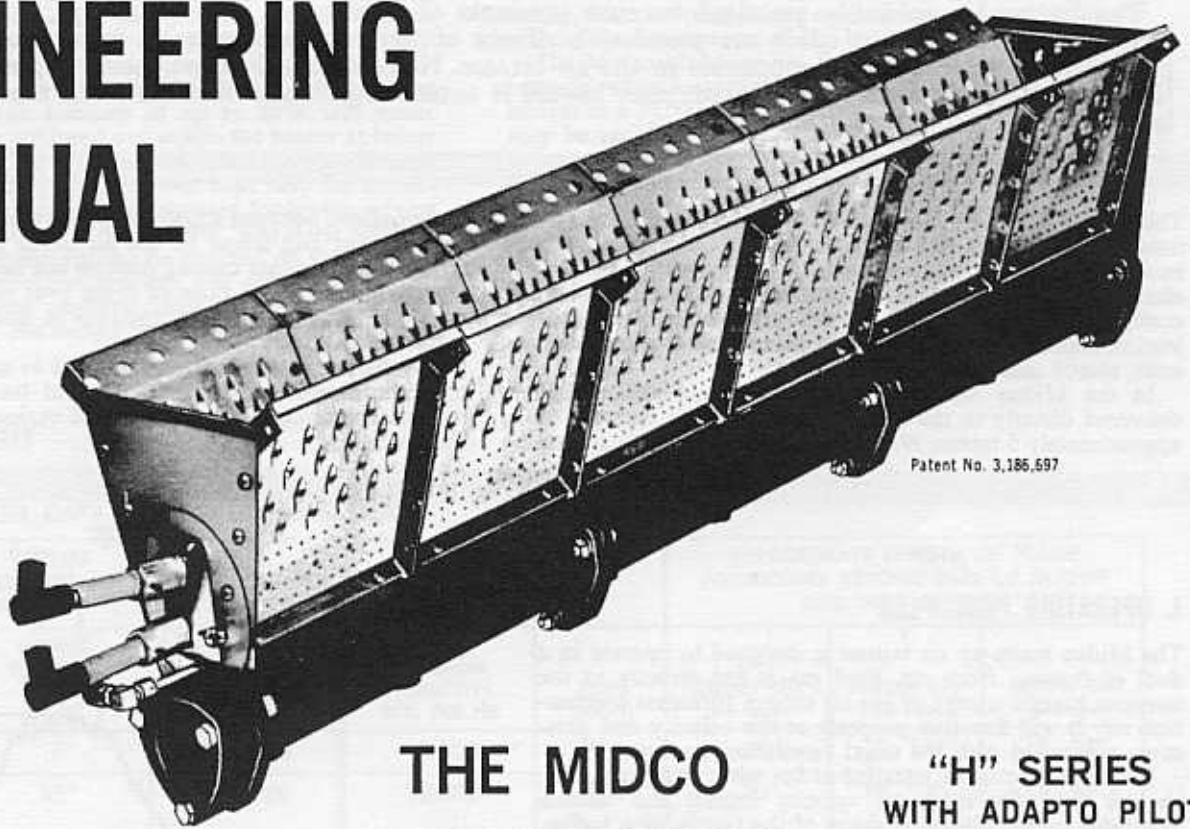

Patent No. 3,186,697

THE MIDCO
WIDE RANGE
MAKE-UP AIR BURNER
HEATS AIR
SIMPLY ... ECONOMICALLY
... without pre-mixing!

"H" SERIES
WITH ADAPTO PILOT

MIDCO International Inc.

4140 WEST VICTORIA STREET • CHICAGO, ILLINOIS 60646 • (773) 604-8700 FAX: (773) 604-4070 • <http://www.midco-intl.com>

PRINTED IN U.S.A.

797
8470-40

MAKE-UP AIR heaters, in which the Midco Wide Range Make-up Air Burners are used, have found favor in industry and commerce to alleviate heating problems caused by excessive ventilation. Where it is necessary or desirable to replace large amounts of air, heaters of this type are used to temper the incoming air and thus relieve the building heating plant of an extra load.

The heater is preferably gas fired because products of combustion are mixed directly into the air stream and no smoke or odors are permissible. Tests of the Midco burner by recognized authorities prove no measurable carbon monoxide in the air stream. No build-up of contaminants is possible because the make-up air is never re-circulated; once heated it enters and blends with the air in the building and is discharged by the exhaust system.

The Midco Make-up Air Burner operates on a new and unique principle. It eliminates the use of expensive combustion air blowers, proportional gas-air premixing devices, electrical motorized valves, transformers, motor starters and costly control panel wiring, yet will provide results equivalent, or superior, to any burner on the market. It is precision built, sturdy and compact.

In the Midco Make-up Air Burner plain raw gas is delivered directly to the burner ports at a low pressure of approximately 5 inches W. C. The velocity of the air stream

is maintained between 2,500 and 3,200 feet per minute. The arrangement and shape of the air holes in the baffles attached to the burner casting provide the injection of proper combustion air at all rates of firing over the wide range of 30 to 1. This range of turndown is adequate for most applications.

The burner sections are manifolded as needed to accomplish the desired capacity. Elbow and tee burner sections permit adaptation to specific ducts of various cross sectional shapes.

1. OPERATING PRINCIPLES

The Midco make-up air burner is designed to operate in a duct of flowing fresh air. Fuel gas is fed directly to the burners; kinetic energy of the air stream furnishes combustion air. It will function properly at the velocity and pressures associated with the usual ventilating systems.

The burner must be installed to fire with, and parallel to, the air flow. By virtue of velocity impact and suction generated by the diverging shape of the combustion baffles, air is induced through the air ports into the combustion zone. The air supply is constant, though only that which mixes with the gas flowing from the burner ports takes part in combustion.

When a very small quantity of gas is admitted to the burner, sufficient mixing takes place in the low fire slot within the burner casting and combustion takes place in this zone. Since the low fire zone is contained within the burner casting it is effectively shielded from fire disrupting uncontrolled air entry.

As the gas supply is increased the flame progresses into the intermediate fire zone where an additional supply of air is available. At higher or full capacity, mixing occurs at the larger air ports of the high fire zone augmented by air spilling over the end of the baffles.

On a reduction of gas supply the reverse sequence takes place, the flame receding to a location of lesser air supply until the low fire zone is reached.

The system above is suitable for a turndown range of approximately 30 to 1.

2. AIR SUPPLY

The heater will generally contain the blower equipment within the same casing in which the burner is located. Any of the standard type blowers can be used whether of the centrifugal or axial flow (vane-axial, tube-axial or propeller). In either case the air flow must be substantially straight and velocity must be within the proper range to develop the desired turndown and capacity within the space allowed.

The Midco Make-up Air Burner is designed to operate in a make-up air heater and an air stream taken directly from outdoors. Recirculation is not permitted because of the possibility of build-up of contaminants, and is prohibited by

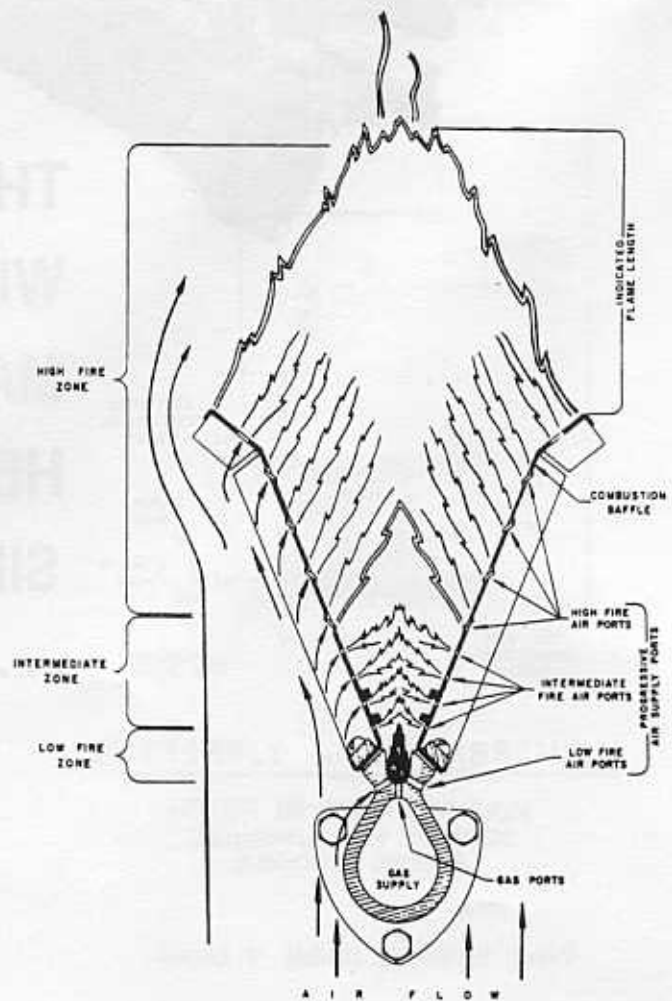

FIGURE 1 COMBUSTION PATTERN

local health codes for this reason. However it can be used with recirculation in certain process heating applications, such as ovens.

To avoid stratification of the heated air, the burners are usually located on the suction side of the blower to take advantage of the mixing effect of the blower. This is known as a PULL-THRU system. In selecting a blower for this case, catalog CFM ratings can be used without correction since the heater outlet temperature of approximately 70° will correspond to the standard blower rating temperature. Motor horsepower rating will also apply directly for operating conditions, though an increase of up to 20% will occur when the inlet air is unheated and enters the heater at below zero temperatures. This will load the motor a corresponding 20% but ordinarily this condition will exist only for a short period during start up and is compensated for by the service factor of the motor, usually 15% to 20%. The static pressure rating of the blower should also be selected on the basis of the standard 70° rating temperature. The entire system will, of course, operate at approximately this temperature in warm weather and the design pressure drop will apply as

calculated. In cold weather the portion of the heater downstream of the burner will remain at 70°, though the inlet side will run at outdoor temperatures, which will result in slightly reduced pressure losses.

The total pressure rating of the blower must include allowance for the resistance of the heater and pressure drop at the burner, together with pressure losses at the inlet screen, inlet louvres, filters, outlet louvres if used, plus the external pressure rating of the heater, if any.

The Midco Make-up Air Burner will also operate satisfactorily when located downstream of the blower, which is known as a PUSH-THRU system, though a mixing plenum may be required at the heater discharge opening. Blower and motor selections must be made on the basis of corrections for the coldest anticipated inlet temperature. In this system the heater outlet CFM will vary due to the expansion of air on heating.

Refer to Midco for further information regarding special applications or push-thru systems.

3. BURNER CAPACITY

TABLE 1 DESIGN DATA (FOR PULL-THRU SYSTEM)

AIR FLOW AT BURNER BASED ON 70° (STD) BLOWER RATING		BURNER CAPACITY (PER FOOT) NAT & LP GAS			APPROXIMATE LENGTH OF FLAME PROJECTING BEYOND END OF BURNER AND PROFILE PLATE *		
DESIGN VELOCITY FPM	DESIGN PRESSURE DROP "W.C."	MAXIMUM CAPACITY BTU. PER HR.	MINIMUM CAPACITY* BTU. PER HR.	TURN DOWN	450,000 BTU per foot	500,000 BTU per foot	550,000 BTU per foot
3200	.7"	550,000	19,000	29:1	7 - 8"	10 - 11"	13 - 14"
2850 (ideal)	.55"	550,000	18,000	30:1	9 - 10"	12 - 13"	15 - 16"
2500	.45"	550,000	17,000	32:1	11 - 12"	14 - 15"	17 - 18"

REDUCE CAPACITY 4% PER EACH 1000 FT. ALTITUDE OVER 2000 FT.

* Flame lengths are given to the end of the main mass of flame, excluding any isolated wisps or flashes, and for normal operation — that is, with cold inlet air (design minimum).

AIR FLOW VARIATIONS DUE TO HEATING IN A PULL-THRU SYSTEM

Velocity and pressure drop figures shown in Table 1 apply to standard design conditions. However these conditions apply only when air enters the heater at 70° and requires little or no heat. In practice with the burner operating, these figures will vary, especially with inlet air at the minimum design temperature. This is because the blower handles a constant volume of air regardless of its temperature. When the air is heated expansion takes place ahead of the blower and just downstream of the burner. It follows therefore that when the air is being heated a lesser volume enters the heater, causing a reduction, both in velocity and pressure drop at the burner. Table 2 shows the variation for minimum temperature air entry and with full input to the burner. Flame lengths given in table 1 apply to conditions shown in table 2.

See Midco Bulletin MA9 for procedure for testing a heater with warm inlet temperatures.

TABLE 2 AIR FLOW VARIATIONS

DESIGN VELOCITY AT BURNER (from Table 1)	DESIGN PRESSURE DROP AT BURNER (from Table 1)	AIR TEMP. RISE	ACTUAL COLD AIR VELOCITY AT BURNER	ACTUAL COLD AIR PRESSURE DROP AT BURNER
3200 fpm	.7" W.C.	75°	2750 fpm	.52" W.C.
		100°	2600 fpm	.46" W.C.
2850 fpm	.55" W.C.	75°	2450 fpm	.41" W.C.
		100°	2300 fpm	.36" W.C.
2500 fpm	.45" W.C.	75°	2150 fpm	.33" W.C.
		100°	2000 fpm	.29" W.C.

EXAMPLE: A heater rated for 100° rise, 70° outlet temperature at a design velocity of 2850 fpm and a design pressure drop of .55" W.C., will in actual operation pass 2300 fpm over the burner with a .36" W.C. drop when air enters at -30°.

4. HEAT REQUIREMENTS, BURNER LENGTH AND PROFILE AREA

The fuel consumption is determined only by air delivery of the heater and the desired temperature rise. The air delivery of the heater or group of heaters is usually equal to, or slightly in excess of, the total exhaust potential of the building ventilating system. The temperature rise is the difference between the coldest anticipated outdoor temperature and desired outlet temperature, usually a few degrees above indoor temperature.

The burner capacity must be accurately correlated to the heat demand for best results. If it were undersized, it is obvious that in severe weather the outlet temperature would

be too low. On the other hand, oversizing will displace the burner turndown range, wasting some of the maximum capacity potential and causing too great a temperature rise at low fire. However, the wide turndown range allows some latitude in sizing since in actual practice the extreme range will rarely be required.

THE CALCULATIONS AND THE EXAMPLE FOLLOWING APPLY TO A PULL-THRU SYSTEM. Calculations are simple because, as noted above, the usual outlet temperature will approximately match standard conditions (70°). PUSH-THRU systems require corrections for varying air temperature at the blower, as do high outlet temperature systems, which are not covered by these instructions.

HEAT REQUIREMENTS

INSTRUCTION	FORMULA	EXAMPLE
		Assume a heater with an air delivery of 27,500 cfm. Min. outdoor temp. -20° Desired outlet temp. 85°
1. Calculate temperature rise. (Outlet temperature usually designed for 75° to 85°)	Outlet temperature less inlet temperature	105°
2. Determine permissible rise in mild weather (usually 4° to 6°).		5°
3. Calculate turn down ratio	$\frac{\text{Maximum rise}}{\text{Minimum rise}}$	$\frac{105^\circ}{5^\circ} = 21 \text{ to } 1$
4. *Calculate maximum hourly BTU	$\frac{\text{Cfm} \times \text{maximum rise} \times 1.1}{.92}$	$\frac{27,500 \times 105 \times 1.1}{.92} = 3,300,000$
5. Calculate minimum hourly BTU	$\frac{\text{Maximum input}}{\text{Turn down ratio}}$	$\frac{3,300,000}{21} = 157,000$
*Formula above includes 1.1 constant for heat content of air and .92 factor, which is an average ratio of net and gross heating value of common fuel gases.		

BURNER LENGTH

The ideal burner length is such as to sufficiently spread the heat in front of the blower to yield uniform outlet temperatures. Other factors to consider are: air pressure drop at the

burner, flame length, turn-down ratio, burner to heater casing clearance, and the maximum per foot capacity rating of the burner.

INSTRUCTION	FORMULA	EXAMPLE
1. Divide maximum hourly BTU by 550,000 to determine minimum feet of burner	$\frac{\text{Total maximum capacity}}{\text{Per foot maximum capacity}}$	$\frac{3,300,000}{550,000} = 6 \text{ ft.}$
2. Check your heater cross section for physical fit of burner	See Section 4 and Figure 6	Assume 6½ ft. straight burner desirable
3. Recalculate per foot capacity for actual burner length	$\frac{\text{Total maximum capacity}}{\text{Actual burner length}}$	$\frac{3,300,000}{6\frac{1}{2}} = 510,000 \text{ per ft.}$
4. Determine air velocity at burner	See Section 2 and Table 1	Assume 2850 fpm. (.55" pressure drop)
5. Calculate minimum BTU requirements per foot	$\frac{\text{Total minimum capacity}}{\text{Burner length}}$	$\frac{157,000}{6\frac{1}{2}} = 24,000 \text{ BTU per ft.}$
6. Determine burner minimum capacity rating	See Table 1	Minimum = 18,000 BTU per ft. therefore 24,000 acceptable
7. Check operating characteristics	See Tables 1 and 2	Flame length = approx. 13" Actual velocity at -20° = 2,300 ft. Actual pressure drop at -20° = .36" W.C.

PROFILE AREA

In calculating velocity consider only the open area (profile area), less the area occupied by the burner. The burner

width at the flame baffle is $7\frac{3}{8}$ "; thus a one-foot section will cover $94\frac{1}{2}$ sq. inches or .65 sq. feet. See Page 11 for areas of other sections.

INSTRUCTION	FORMULA	EXAMPLE
1. Calculate total burner area	Feet of Burner x area per foot	$6\frac{1}{2}' \times .65 = 4.2$ sq. ft.
2. Calculate net profile area	$\frac{\text{Total cfm}}{70^\circ \text{ velocity}}$	$\frac{27.500}{2850} = 9.6$ sq. ft.
3. Calculate gross profile area	Burner & net area combined	$4.2 + 9.6 = 13.8$ sq. ft.
4. Calculate length of profile opening	Burner length plus 4" each end	$78'' + 4 + 4 = 86''$ (7.15 ft.)
5. Calculate height of profile opening	$\frac{\text{Gross profile area}}{\text{Length}}$	$\frac{13.8}{7.15} = 1.93$ ft. = 23"

5. APPLICATION TO HEATER

The heater design must provide the proper operating conditions for the burner.

Generally, where the heater casing contains both the burner and blowers, the air velocity will be less than optimum due to the bulk of the blowers. In this case an adjustable restriction (profile plate) must be installed at the burner to step up the velocity to requirements. See Figure 2.

The profile plate can be omitted in duct installations where the duct dimensions are such that the proper flame to wall clearances can be maintained and air velocities will fall into the proper range. However, where the duct is undersized and optimum velocities would be exceeded, an expanded heater section should be built. It should be made large enough so that an adjustable profile plate can be installed. See Figure 3.

To promote even outlet temperature the burner assembly should be arranged to spread the flame proportionally throughout the heater cross section. In the case of square heater casings, typical or axial flow or single centrifugal blowers, the burner pattern will likewise be generally square. For rectangular casings typical of multiple centrifugal blower installations, concentration of heat in the center should be avoided, and the pattern of the burner should span the width of the heater.

The profile clearance from ends of the burner, whether they be legs of a pattern or ends of a straight burner, should be kept moderate; approximately 4" to prevent passage of unheated air. No part of the burner should be located within 6" of the heater or duct wall. (12" top clearance is recommended.) If necessary, the heater cross section must be increased and additional profile plate area added to maintain clearance.

Cantilevered burner assemblies should not exceed 3 feet in length.

The gas inlets must be properly spaced and sufficient in number to provide an ample and even gas flow. See Section 8.

The profile plate opening should be arranged to generally follow the shape of the burner to correlate air flow and heat output. Adjustable profile plates should be equipped with stops so that clearances less than 1" from the burner will be impossible. The open area inside of a looped burner arrangement can also contain a profile plate if required to maintain velocities or to close off a potential cold air stratum.

Allow at least 18" beyond expected flame length before heated air encounters any heater structure or blower components.

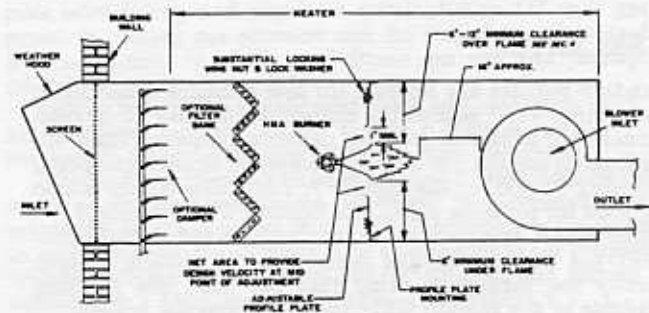

FIGURE 2 INSTALLATION IN HEATER

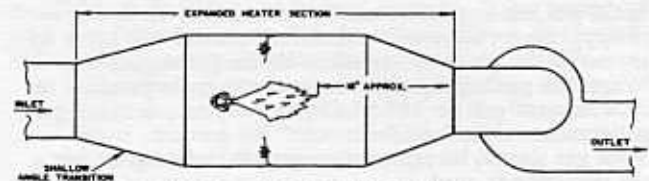

FIGURE 3 INSTALLATION IN DUCT

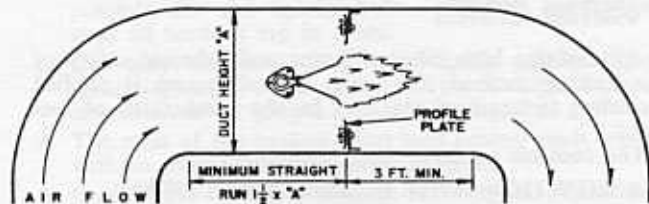

FIGURE 4 ELBOW DUCTS LIMITS

The air flow at the burner must be substantially straight, otherwise an uneven fire and temperature will result. Sharp changes in direction or large obstructions immediately in front of the burner should be avoided. See Figure 4.

Closing dampers at the fresh air inlet may be used if

extended shut down periods are anticipated. However, such devices must be equipped with a limit switch which interlocks into the control system to prevent burner operation unless the damper is fully open.

The fresh air intake should be located where a continuous supply of fresh air is available. It should be tilted downward and screened to prevent entry of rain, snow, birds, leaves, etc. If dusty outdoor atmospheres prevail, a filter bank should be employed in the intake.

While it is permissible to place minor control components in the air stream, it is recommended that items requiring adjustments, and the major control components, be located outside of the air stream. In any case, temperature sensitive control components such as automatic valves must be low temperature rated if located in the air stream or if used on outdoor heaters.

Access openings should be located to allow entry into the heater at the burners, filters and automatic louvers, if used. Observation ports should also be installed in close proximity to the controls and in a position to permit clear sight of the pilot and main flame. A permanent service platform on suspended heaters will encourage routine inspection and maintenance.

6. GAS SUPPLY

Standard burners are suitable for low pressure natural gas, and require 4½" w.c. at the burner for the full firing rate. Burners are available for low pressure propane. They are identical to natural gas burners except for smaller gas ports, requiring 8" w.c. at the burner. A restricting orifice is also required for propane pilots. See Section 8 and Figure 7.

The HMA burner can be used with mixed or manufactured gas though the gas ports must be drilled to suit. Specify the maximum firing rate per foot, gas pressure available at the burner, BTU value and specific gravity.

In any case above, the pressure drop of the piping and controls should not exceed the difference between the burner pressure and the lowest normal pressure of the gas supply.

Main gas line regulators are not mandatory on low pressure applications since the modulating control will serve to compensate for pressure variations of the gas supply.

When the gas supply exceeds normal supply pressure of 7" for natural gas or 11" W.C. for propane, a main gas regulator should be installed.

Pilot gas should be separately regulated whether or not a main regulator is used.

7. CONTROL SYSTEM

In spite of the high dilution factor and inherent safety of this heating method, the basic control system is applied according to standard practices for the combustion of fuel gases.

The controls perform three functions:

1. IGNITION AND FLAME SUPERVISION.
2. SAFETY INTERLOCKS.
3. TEMPERATURE CONTROL.

1. IGNITION AND FLAME SUPERVISION

The ignition system can be arranged for either:

- A, Direct main burner spark ignition
- B, Spark Ignition intermittent pilot
- C, Spark ignition interrupted pilot

The HMA burner is usually used with flame rectification supervisory systems. The flame rod furnished with the burner can be used with any of the commercially available systems. The flame safeguard relay must provide at least sequenced ignition, flame proving and main burner control

such as is the Minneapolis Honeywell RA890F, though full programming relays such as the M.H. R4074A, R4795 and Fireye FC-2 can be used if desired.

Scanner mountings are also available for U.V. flame supervision.

Due to the high dilution of the fuel gas, pre-purging is not mandatory for make-up air heaters.

In addition to the safeguard relay, the following components will be required to carry out the function of ignition and flame supervision:

- I. Piloted Burners:
 - A. Automatic pilot valve, usually of the solenoid type, having a capacity of 20,000 BTU.
 - B. Ignition transformer.
- II. Direct Spark Ignition Burners:
Ignition transformer.
- III. Both systems above:
Main automatic valve, either motorized current failure type or reset type either manual or motorized. Motorized valve should preferably slow opening (30 to 60 sec.) to allow temperature control response before full valve opening in mild weather. Manual reset valves can, of course, be used only with manually operated heaters. The main valve and other main piping components must be sized to allow gas pressure of 4½" W.C. at the burner at full capacity for natural gas, or 8" W.C. for propane.

2. SAFETY INTERLOCKS

Any factor which can influence the safe operation of the heater must be interlocked into the flame safeguard relay to prevent burner start up or cause shut down, if unsafe conditions exist. Commonly they will be:

- I. Air Flow:
 - A. Blower starter interlock.
 - B. Air pressure differential switch, or vane type flow switch or blower shaft rotational switch. Vane type is best located at blower discharge where velocities are the highest. If a pressure switch is furnished it is recommended that a differential type be used, connected to inlet and outlet side of blower, or across the profile plate.
- II. Excess temperature:
A manual reset high limit switch must be installed in the heater, to protect against dangerously high temperatures whether due to excess fuel consumption or reduced air flow (augments I above.)
- III. Damper:
Limit switches must be mounted at main air louver assemblies to prevent burner operation unless dampers are fully open.
- IV. Gas Pressure:
Manual reset pressure switch should be used on high pressure gas systems to protect against regulator failure unless main automatic gas valve and modulating valve are rated for pressures equal to or exceeding gas service pressure. Low pressure switches are not mandatory since lack of pressure will simply result in a smaller, or no, fire.

3. TEMPERATURE CONTROL

- I. Outdoor thermostat, usually of the remote type. It measures intake air temperature and functions to determine when burner operation should take place. It also functions to maintain steady burner operation

in mild weather when the difference between design outlet temperature and inlet temperature is less than the minimum rise through the heater. Its operating point is set just below designed outlet temperature.

- II. Modulating control serves to maintain comfortable outlet air temperature. It can be electrically operated, pneumatic or, for the smaller heaters (under 2,000,000 BTU), it can be direct acting. In either case the remote pickup element must be of the sensitive type for accurate and responsive temperature control. The valve must be tight (or near tight) shut off to effectively control the wide range of gas flow. It must also be equipped with an adjustable low fire stop, or an adjustable low fire by-pass. The modulating valve capacity should be accurately sized to achieve accurate modulating control. A pressure drop of .2" to .4" W.C. at maximum capacity should be taken through it so that modulation takes effect promptly with a minimum of wasted valve travel.

See Table 3.

In normal winter operation the heater will run almost continuously; therefore, low fire starting will prove of little value from a comfort standpoint. Further, it is not necessary for lighting; in fact a slight surge on starting is desirable for prompt burner ignition.

"Reset" temperature controls can be used where it is desired to provide the ultimate in comfort by automatically raising the outlet temperature in cold weather. See your control manufacturer for recommendations.

If the heater is intended to be operated for extended periods in an unattended building it is recommended that a low limit thermostat be installed in the heater outlet to prevent the discharge of cold air. It should be set above freezing temperature to avoid risk of freezing water pipes in the building in the event that the burner shuts off for any reason. A momentary contact push button, or other provision, must be installed to allow starting when the low limit is out. Figure 5 shows a suggested hook-up of a by-pass integral with the motor start button, together with a light to indicate that the heat has been established and that the button can be released.

8. BURNER ASSEMBLY

When planning the actual burner configuration the following points should be observed.

Adapto assembly No. 1343. Most commonly used, for pilot ignition and rectification pilot proving, (intermittent pilot). For pilot proving and main flame monitoring (interrupted pilot), use in combination with the remote flame rod assembly No. 1346, mounted on the opposite end of the burner. In this arrangement the flame safeguard must sequence to shut off the pilot after main burner ignition leaving the remote rod for main flame sensing. Alternately, the pilot can be left burning and the flame rod circuit can be arranged to shift to the remote flame rod after main burner ignition.

Adapto assembly No. 1345. Equivalent to the above except for use with a U.V. scanner. It is suitable for an intermittent pilot or for an interrupted pilot. In the latter case no remote scanner is required, since it will monitor the main flame after the pilot is shut off. However, if it is desired to prove full length flame travel, especially on long burners or around an elbow, a remote U.V. scanner assembly No. 1348 may be mounted at the end of the burner opposite the pilot. Caution: U.V. scanners will respond to the ignition spark (or its reflection), as well as the flame. Thus, to prove the pilot the flame safeguard must sequence to interrupt the spark before energizing the main gas valve. Alternately, for Honeywell flame safeguards, a half cycle spark generator (Honeywell Q624A), can be used in place of the common ignition transformer, which eliminates the spark effect. See Figure 7 for increase in spark gap.

Adapto assembly No. 1344. Used for direct ignition systems, usually for heaters less than 1,000,000 BTU. It is used in combination with the remote flame rod assembly #1346 for rectification flame monitoring. Ignition takes place at one end of the burner, flame proving at the opposite end. A small portion of the main gas is by-passed around the modulating valve to provide a fixed fuel flow area at the ignition electrode for dependable ignition with a single transformer. See Figure 6.

GAS INLET CAPACITIES

INLET SIZE	MAXIMUM FEET OF BURNER		
	NATURAL	PROPANE	MFD.
1½" I.P.S. end inlet	4'	5'	3'
2" I.P.S. back inlet centrally located	6½'	8'	4½'

The ideal pilot gas pressure for Adapto pilots is nominally 3 to 3½" w.c. for natural gas. Propane pilots are identical to natural gas pilots except for a restricting orifice in the pilot inlet fitting, and require a nominal 9 to 11" w.c. gas pressure. Actual gas pressure can be varied to suit actual job conditions, to yield good flame current and prompt pilot ignition.

Adapto assemblies are shipped loose and separately packaged. Do not mount until the burner has been installed in the heater. Check electrode settings before mounting.

Adapto assemblies can be used in combination with either blank or threaded end flanges. However, the accompanying end baffle, which is a part of the flange assembly is modified to accommodate the Adapto. The flange number is suffixed "A" to indicate the provision for an Adapto, and left unsuffixed for a plain end application. (See Figure 8.)

Large burner assemblies may be shipped broken down into convenient sized pieces for simpler handling and shipping. Also, the heater manufacturer may find it advantageous to maintain an inventory of burner sections, to be assembled into any shape when needed. In either case, a few simple but important assembly instructions should be heeded:

1. The burner joints are sealed with a thin coating of furnace cement or graphite paste on the flanged faces. When cleaning off "squeeze out" make sure that it is not wiped into the gas or low fire air ports.
2. When joining burner sections, line them up so that the slot and baffle mounting surfaces match as closely as possible. Do not tighten bolts in looped assemblies until all sections are in place.
3. Use only new and undamaged baffle gaskets. The matching burner surface must be free of ridges, bumps or adhesions for proper seating of the gasket.
4. The ends of the gaskets must butt against each other without overlapping, to leave no gaps.
5. Gaskets are furnished only in 12" lengths. For other lengths, cut accurately to size required.
6. After all baffle plate screws are tightened check for potential air leaks at the gasket surfaces and between baffle joints, particularly in the low fire zone. No light will show through a good joint. Baffle plate flanges can be lightly hammered together for a good fit. If necessary, close up any remaining gaps with furnace cement.
7. Refer to Figure 7. Note that the port under the pilot gas tube is to be plugged. (Use furnace cement.) This applies to burners for use with No. 1343, 1344 and 1345 Adapto assemblies.
8. If painting is required use a paint that will not soften or blister at 500°. Do not paint over low fire air ports in the casting and do not paint baffles or pilot.
9. When assembly is complete check for clogged gas and air ports.

9. START UP AND ADJUSTMENT

This sequence applies to the control system diagrammed in Figure 5. Different systems will, of course, alter heater operation to suit, but burner adjustment will be the same in all cases.

1. Make sure that main and pilot manual valves are closed but that gas is available in service line.
2. Set outdoor thermostat above outdoor temperature. Set high limit and modulating control above outdoor temperature plus maximum design temperature.
3. If modulating valve has a high fire stop, set it wide open. Set low fire stop or by-pass partly open.
4. Start circulating blower. If dampers are used check to see they are open.
5. Check and set: air flow, damper and gas pressure interlocks.
6. Energize burner control system. Check that flame safeguard relay is "set".
7. Check for ignition spark.
8. Open pilot manual valve. Check for prompt pilot ignition and check flame safeguard response. Check flame current. Pilot regulator can be readjusted if necessary.
9. Open main manual valve to light the burner. Check for flame over the entire length.
10. Check meter gas rate. If too high set at desired rate, first by reducing pressure setting on main regulator, and second by reducing high first stop setting on modu-

lating valve. If no high fire adjustment is available reset modulating control to design temperature rise, plus current outdoor temperature to approximate full input. If input is too low increase setting on main regulator, but not past point where no further pressure increase is evident.

11. Check the flame length at **design temperature rise**. If it is too long, or if it contains excess yellow flame, or if it tends to rise, low air velocity is indicated. If the flame is very short and all blue, excess velocity is apparent. Shut down heater and adjust profile plates as required.
12. With burner running, reset modulating control to point less than incoming air temperature to drive valve to low fire position. Then gradually reduce low fire stop, or by-pass, till the fire tends to go out. Increase to the smallest stable, full length fire. If a local weak spot appears, check for clogged low fire air ports or extreme turbulence at affected portion. Make low fire adjustments patiently. Due to low gas flow rate, response to adjustments will be slow.
13. Make final setting of outdoor thermostat and modulating control. Set limit approximately 100° over normal outlet temperature.

Slight redness of the alloy baffle plates may occur at the higher inputs. This will not harm them. Some warpage of the baffles may also occur; however most will disappear on cooling. Once an initial warp has taken a "set" no further permanent warpage will take place.

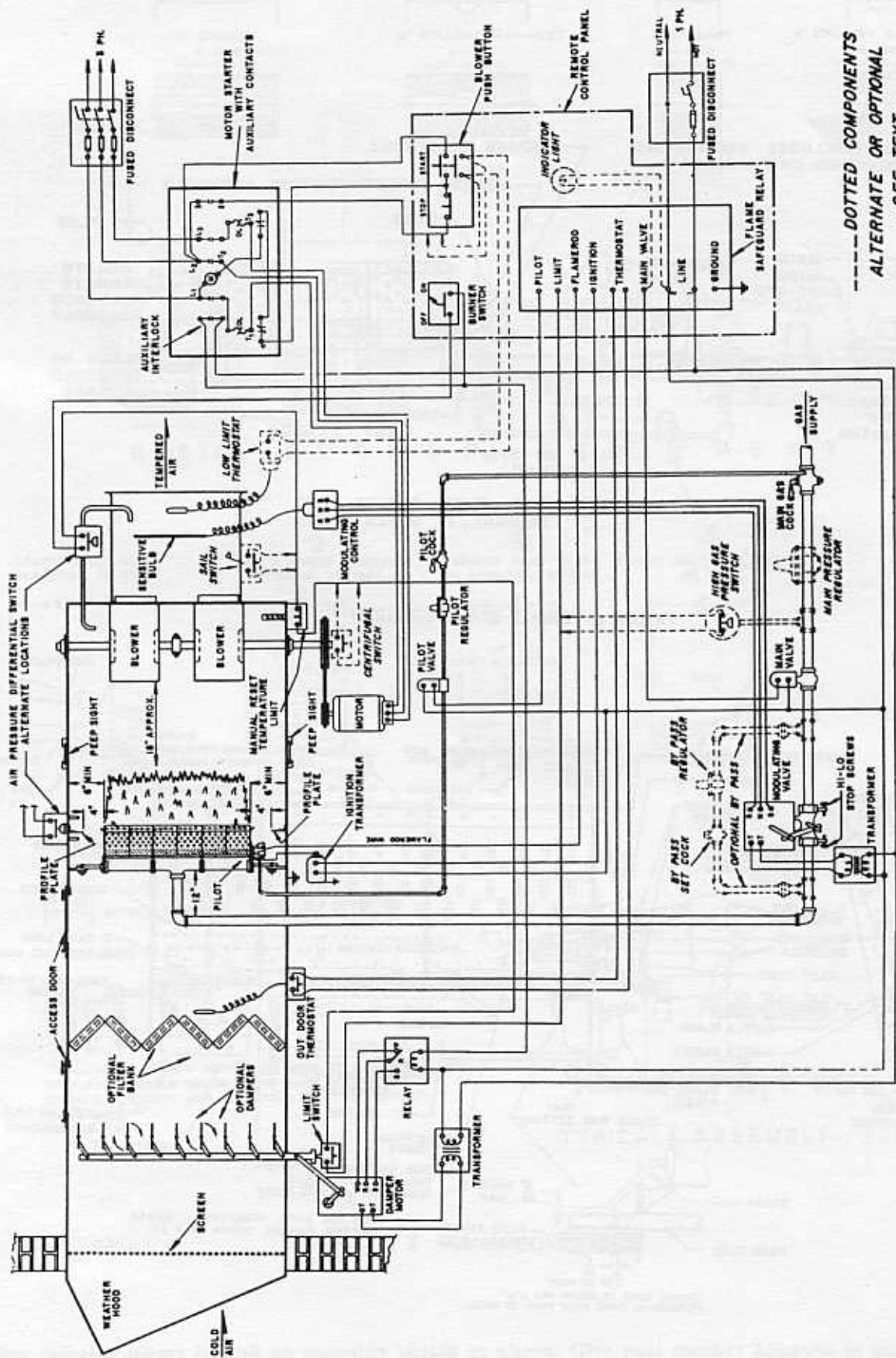

--- DOTTED COMPONENTS
 ALTERNATE OR OPTIONAL
 --SEE TEXT--

FIGURE 5 BASIC CONTROL SYSTEM

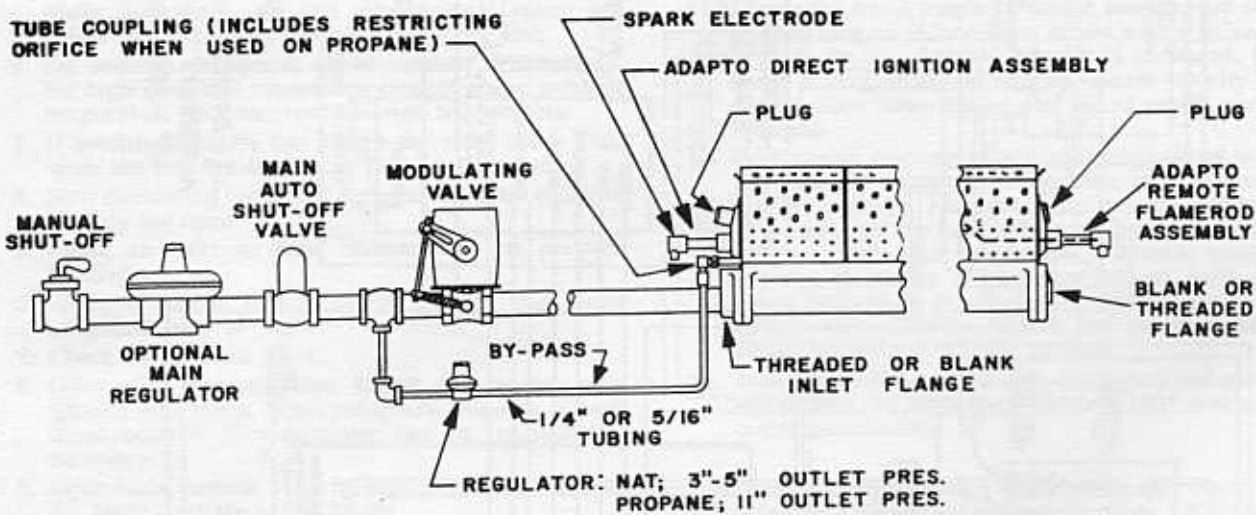

FIGURE 6 DIRECT SPARK IGNITION

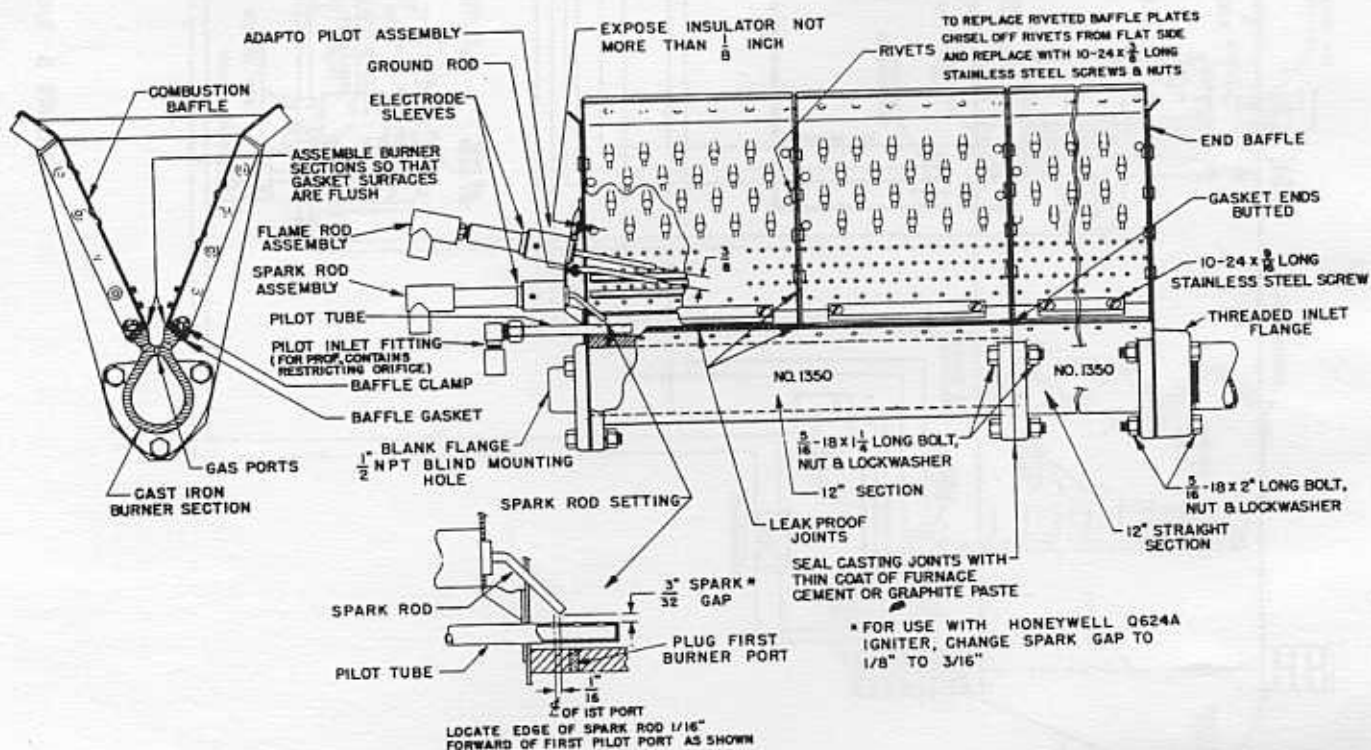
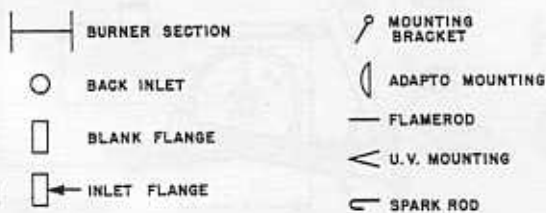
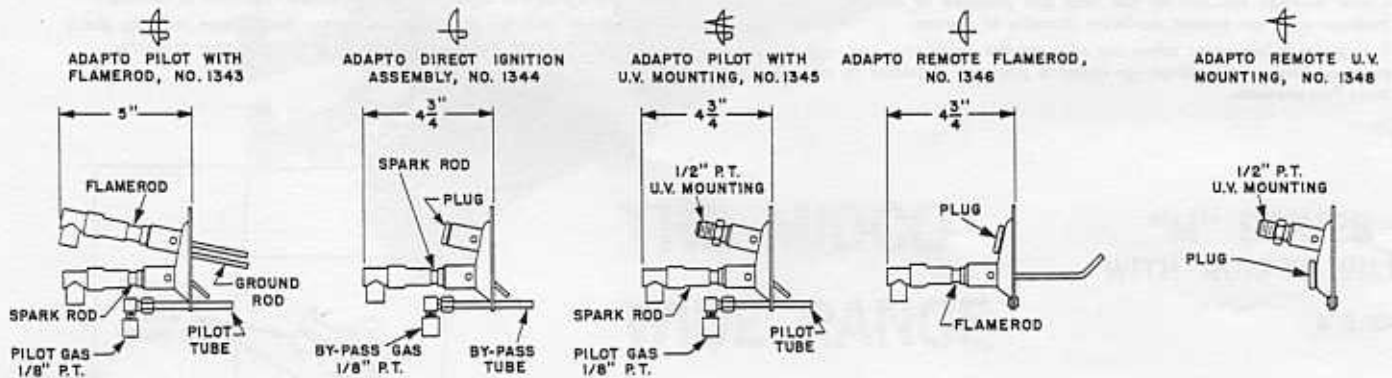
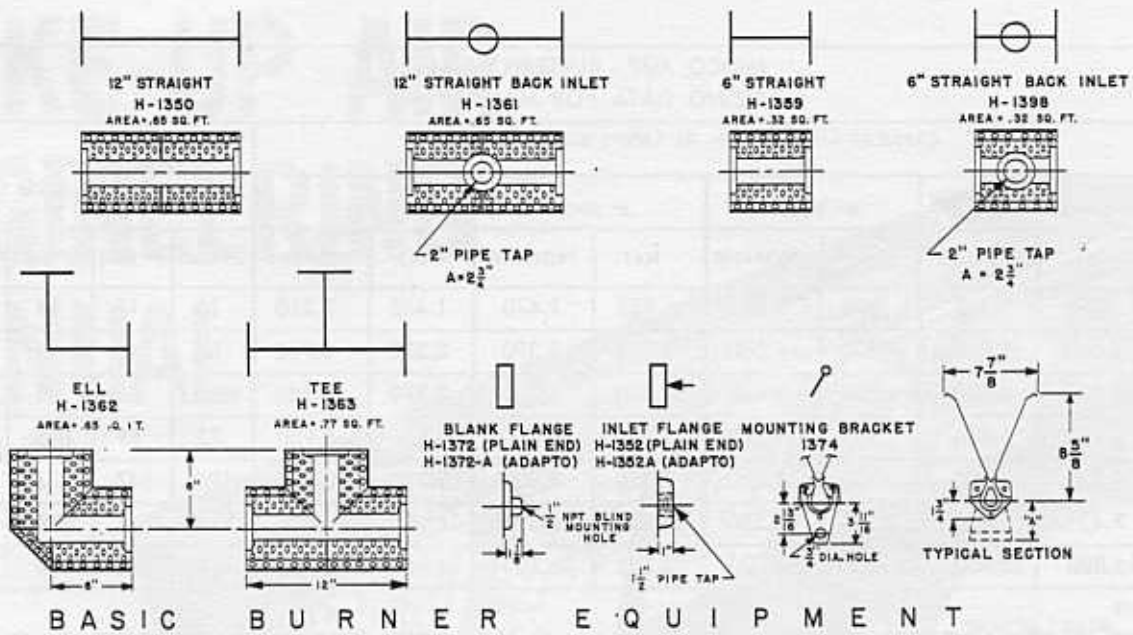

FIGURE 7 BURNER ASSEMBLY



THE ELEMENTS SHOWN ABOVE ARE USED TO CONSTRUCT THE COMPLETE SYMBOLS SHOWN ABOVE EACH BURNER DRAWING. SYMBOLS REPRESENT VIEW OF BURNER FROM SIDE OPPOSITE FLAME EXIT.

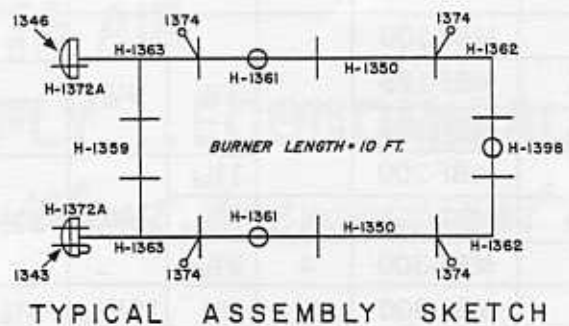

FIGURE 8 BURNER COMPONENTS

When ordering please furnish an assembly sketch as above. Give part number adjacent to each part symbol and specify total flame length. Specify type of gas.

TABLE 3

MIDCO MBF BUTTERFLY VALVES
SIZING DATA FOR MA BURNERS

VALVE SIZE	CAPACITY - WIDE OPEN IN 1,000'S BTU PER HR.								MAXIMUM LEAKAGE IN CLOSED POSITION IN 1,000'S BTU/HR.			
	.2" DROP		.3" DROP		.4" DROP		1" DROP		5" NAT	7" NAT	10" NAT	11" PRO-PANE
	NAT	PROPANE	NAT	PROPANE	NAT	PROPANE	NAT	PROPANE				
1 "	655	1,040	800	1,270	925	1,470	1,455	2,310	10	12	14	23
1¼"	1,060	1,680	1,300	2,060	1,505	2,390	2,370	3,760	38	45	54	89
1½"	1,510	2,400	1,850	2,940	2,140	3,400	3,370	5,350	55	65	78	129
2 "	2,530	4,020	3,100	4,920	3,580	5,670	5,650	8,950	75	89	106	175
2½"	4,350	6,900	5,350	8,500	6,180	9,800	9,750	15,500	125	147	177	292
3"	7,425	11,800	9,100	14,500	10,500	16,650	16,550	26,300	210	248	298	492
4"	16,300	25,900	20,000	31,700	23,100	36,700	36,400	57,700	410	485	580	985

INSTRUCTIONS

1. For the usual low pressure natural gas system (5" to 7" w.c. inlet), or for low pressure propane (11" w.c.), select a valve size which will yield desired capacity at .2" or .3" or .4" w.c. pressure drop.
2. Check leakage capacity at the inlet gas pressure to determine that leakage does not exceed minimum capacity of burner.
3. If leakage is too great select the next smaller valve size and recheck pressure drop and leakage—or install a pressure regulator to reduce main line pressure.

NOTES

1. 1" w.c. pressure drop capacity is shown for cases when main line pressure is sufficient to allow the higher drop. Be sure to particularly check the leakage capacity for the higher gas pressures which are usually encountered in these cases. Install a pressure regulator if necessary.
2. To determine leakage for conditions other than shown multiply given leakage by ratio of the square roots of given and new pressure.

TABLE 4

VALVE SIZE N.P.T.	MODEL NUMBER	A	B	C	D
1	MBF-100	2 ¹⁵ / ₁₆	1 ³ / ₈	9 ¹ / ₄	1 ⁷ / ₈
1¼	MBF-125				1 ³ / ₄
1½	MBF-150		1 ¹⁵ / ₁₆		2 ¹ / ₂
2	MBF-200		3 ³ / ₄		1 ¹³ / ₁₆
2½	MBF-250	4	2 ³ / ₁₆	10 ¹¹ / ₁₆	3 ¹ / ₄
3	MBF-300				
4	MBF-400				

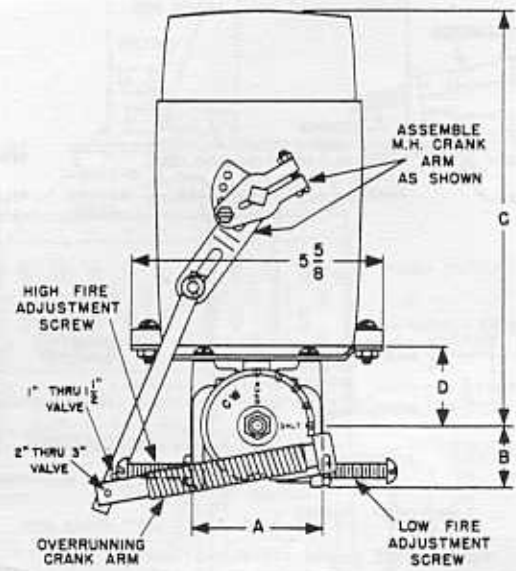

BUTTERFLY VALVE ASSEMBLY

MOTOR IN SHUT POSITION
(TERMINALS R&W SHORTED)
CLOCKWISE OPENING

FIGURE 9 MIDCO BUTTERFLY VALVE