

Pollution Control Unit
Installation, Operation, and Maintenance Manual



Pollution Control Unit



RECEIVING AND INSPECTION

Upon receiving unit, check for any interior and exterior damage, and if found, report it immediately to the carrier. Also check that all accessory items are accounted for and are damage free.

WARNING!!

Installation of this unit should only be performed by a qualified professional who has read and understands these instructions and is familiar with proper safety precautions. Read this manual thoroughly before installing or servicing this equipment.

Save these instructions. This document is the property of the owner of this equipment and is required for future maintenance. Leave this document with the owner when installation or service is complete.

TABLE OF CONTENTS

WARRANTY	3
LISTINGS	4
APPLICATION	4
INSTALLATION	5
Site Preparation	5
Joint Sealant	5
Sealant Features	5
Ductwork	6
Unit Drains	6
Equipment Rails	7
Roof Mount Installation (Typical)	7
Indoor (Inline) Installation (Typical)	7
Air Pressure Switch Option	8
Advanced Filter Monitoring Option	9
PCU AFM LCD Menus	10
LCD Menu Tree	12
PCUAFM Wiring	14
Fire System	15
Climate Controlled Utility Cabinet	15
Bolted Door Design	17
OPERATION	18
Start Up	18
Special Tools Required	18
Start Up Procedure	18
Troubleshooting	19
Troubleshooting Chart	19
Fault Chart	20
MAINTENANCE	21
General Maintenance	21
Filter Information	21
Standard Filter Part Numbers	22
Optional Pre Filter, High Efficiency, and HEPA Filter Part Numbers	22
Optional Odor Control Media Part Numbers	22
Gasket Type Chart	23
2 Weeks After Startup	23
Every Month	23
Duct Cleaning	23
Yearly	23
Job Information	24
PCU Information	24
Advanced Filter Pressure Monitoring Information	24
Maintenance Record	24

WARRANTY

This equipment is warranted to be free from defects in materials and workmanship, under normal use and service, for a period of 12 months from date of shipment. This warranty shall not apply if:

1. The equipment is not installed by a qualified installer per the MANUFACTURER'S installation instructions shipped with the product,
2. The equipment is not installed in accordance with federal, state and local codes and regulations,
3. The equipment is misused or neglected,
4. The equipment is not operated within its published capacity,
5. The invoice is not paid within the terms of the sales agreement.

The MANUFACTURER shall not be liable for incidental and consequential losses and damages potentially attributable to malfunctioning equipment. Should any part of the equipment prove to be defective in material or workmanship within the 12-month warranty period, upon examination by the MANUFACTURER, such part will be repaired or replaced by MANUFACTURER at no charge. The BUYER shall pay all labor costs incurred in connection with such repair or replacement. Equipment shall not be returned without MANUFACTURER'S prior authorization and all returned equipment shall be shipped by the BUYER, freight prepaid to a destination determined by the MANUFACTURER.

LISTINGS

This Pollution Control Unit (PCU) is ETL listed to UL-710, CAN/ULC-S646, CAN/ULC-S647, and UL listed to UL-1978/CAN/ULC-S662 (Bolted door design) when installed in accordance with these installation instructions and National Fire Protection Association Standard "NFPA 96, Standard for Ventilation Control and Fire Protection of Commercial Cooking Operations."

APPLICATION

The listed pollution control unit is suitable for use in commercial cooking installations for the removal of smoke and grease laden vapors.

Grease duct installations require provisions for cleaning the interior of the duct. NFPA 96 cleanout requirements are as follows:

1. A cleanout must be provided at each change of direction except where the entire length of duct can be inspected and cleaned from either the hood or the discharge end.
2. On horizontal duct runs, at least one (1) 20" diameter opening must be provided. Where the opening is smaller than 20" diameter, openings large enough to permit cleaning must be provided at intervals of no more than 12'.
3. Openings in the duct must be at the side or the top, whichever is more accessible. When the opening is on the side of the duct, the lower edge of the opening must be at least 1 ½" above the bottom of the duct. For listed grease duct, this is accomplished by the use of the grease manifold tee and cleanout cap.
4. On vertical duct runs where personnel entry is possible, access must be from the top of the riser. Where entry is not possible, access must be provided at each floor.

NOTE: ACCESS REQUIREMENTS ARE SUBJECT TO CHANGE IN ACCORDANCE WITH LOCAL CODE. LOCAL AUTHORITIES SHOULD BE CONSULTED FOR EXACT REQUIREMENTS. GREASE DUCT MAY BE CONNECTED ONLY TO HOODS IN A SINGLE FIRE ZONE ON ONE FLOOR. DO NOT CONNECT GREASE DUCTS TO ANY OTHER PART OF THE BUILDING VENTILATION OR EXHAUST SYSTEM.

A grease fire can burn at extremely high temperatures. This system should be dismantled and inspected after any exposure to a grease fire. Any section that is distorted or discolored should be replaced. All joints in the system should be examined. Because the sealant expands to assure a positive seal in the case of a fire, any sealant that has been exposed to high temperature must be replaced. This will ensure that the system maintains its integrity against fire conditions in the future. The manufacturer of this PCU cannot be responsible for grease duct systems that are not properly maintained or have been subjected to one or more grease fires. Warranty and listing is void in a fire situation without consulting factory.

Grease duct systems size and capacity information may be obtained from the "ASHRAE Handbook – Fundamentals" or from the "Air Pollution Engineering Manual" of the "US Environmental Protection Agency." Refer to the grease duct systems catalog for descriptions and dimensional data of parts.

INSTALLATION

It is imperative that this unit is installed and operated with the designed airflow, filters, exhaust fan placement, and construction in accordance with this manual. If there are any questions about any items, please call the service department at **1-866-784-6900** for warranty and technical support issues.

WARNING: DO NOT RAISE PCU BY THE DOOR, FILTER FRAMES, OR UTILITY CABINET – USE LIFTING LUGS PROVIDED OR A SLING.

Site Preparation

1. Provide clearance around installation site to safely rig and lift equipment into its final position. Supports must adequately support equipment. Refer to manufacturer's estimated weights.
2. Consider general service and installation space when locating unit. Allow a minimum of 36 inches of clearance on the filter removal side of the unit to replace filters.
3. Locate unit close to the space it will serve to reduce long, twisted duct runs
4. Support unit above ground or at roof level high enough to prevent precipitation from being drawn into unit.
5. The PCU is designed to operate in a negative pressure environment. Be sure to install the PCU between the exhaust fan and hoods. This will also keep the fan cleaner during operation.
6. The PCU drains must be connected to the building grease interceptor or an approved building drain. Black Iron or Stainless Steel Pipe must be used for this connection. If PCU assembly has Multiple Modules, the drain line must be 2.5 inch NPT pipe minimum.
7. Determine if adequate room is available to install the PCU assembly and all ductwork with proper clearance to combustible material. **Clearance to combustible surfaces to this PCU unit is 18 inches.** It is important to check with the local authority having jurisdiction to determine that the installation method is satisfactory to meet their requirements prior to installation.
8. When the PCU is installed above or near a finished space, the installing contractor should protect the finished space to prevent water damage in the event of a fire system discharge or when regular cleaning is performed on the unit.

Joint Sealant

The joint sealant used to seal all internal joint assemblies is a 3M product. 3M Fire Barrier 2000 + Silicone Sealant is a ready-to-use, gun-grade, one-component silicone elastomer that cures upon exposure to atmospheric humidity to form a flexible seal. 3M Fire Barrier 2000 + Silicone Sealant, when installed properly, will control the spread of fire before, during and after exposure to open flames. It will stop the spread of noxious gas, smoke and water and maintain the integrity of fire rated assemblies and construction. **NO SEALANT SUBSTITUTES MAY BE USED.**

Sealant Features

1. Superior adhesion.
2. Capable of withstanding 2000 °F + temperatures.
3. Class 25 sealant, per ASTM 920.
4. Re-enterable/repairable.
5. Provides up to 4-hours fire-rating.
6. Cures upon exposure to atmospheric humidity.
7. Working time 30 minutes.
8. Cure time 14 to 21 days.
9. Applied with a standard caulk gun.

Ductwork

The ductwork attached to this unit will significantly affect the airflow performance. Flexible ductwork and square elbows should not be used. **There must be at least 3 duct diameters of straight duct leading to the inlet and at the outlet of the pollution control unit.** The chart to the right shows the recommended duct sizes for optimal performance. **The maximum velocity at the inlet of the pollution control unit must be less than 1000 feet per minute for light duty applications and less than 800 feet per minute for heavy duty applications and solid fuel applications.**

Recommended Minimum Ductwork Sizes Before Transitioning To PCU Inlet

PCU Size	Min Ductwork Diameter
PCU-1	10"
PCU-2	15"
PCU-3	17"
PCU-4	19"
PCU-5	21"
PCU-6	25"
PCU-7	33"

Follow SMACNA guides and recommendations for the remaining duct run.

Ensure duct connections are properly aligned and sealed. When the pollution control unit is used in commercial grease ductwork, the ductwork connections must be **FULLY WELDED** to the PCU. Ductwork must be listed or installed in accordance with the IMC. When pollution control unit is installed in grease rated ductwork, the clearance to combustible surfaces to this pollution control unit is 18 in.

Unit Drains

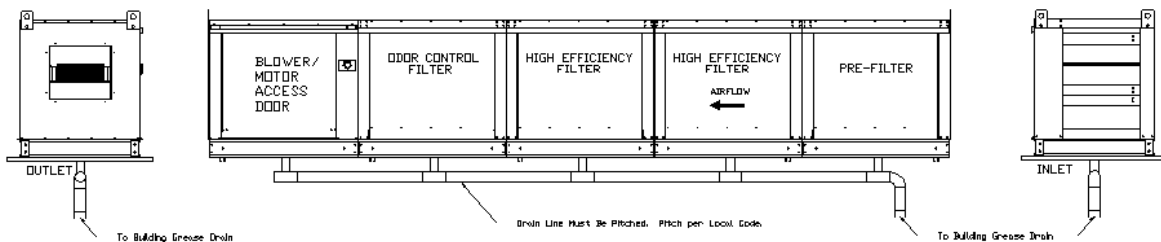

- Note:
- * Grease Inlet Must Be Pitched Pitch Per Local Code Requirements
 - * Grease Inlet Line Must Be Connected To The Building Grease Interceptor Or An approved Drain
 - * Grease Line Must Be At Least 2 1/2" NPT Pipe
 - * Grease Line Must Be Made From Black Iron Or Stainless Steel Pipe
 - * Fittings Must Be Installed Inside To Prevent Drain Line From Freezing

Each module of the Pollution Control Unit contains a drain that **must be connected to an approved grease interceptor or to an approved drainage point.** The drain connections must be made with Black Iron or Stainless Steel piping. This will allow the water collected in the unit, either from Self Cleaning hood, ductwork cleaning, or from the Core Protection Fire System, to drain away from the unit. If installed outdoors, the drains must be piped so that water cannot buildup in the pipes and burst due to freezing.

Equipment Rails

The unit should be installed on a curb and/or rail elevated not less than 14" above any roof surface. Secure PCU to rails through vertical portion of the PCU base assembly flange using ¼-14 x 1.5" long self-drilling screws with a minimum of 4 screws per rail. Shims may be required depending upon equipment rail installation and roofing material. When installed indoors, uni-strut channels may be used under the PCU for attachment to threaded rod from the roof structure above. Check all fasteners for tightness. The diagrams below show different mechanical installation configurations.

Roof Mount Installation (Typical)

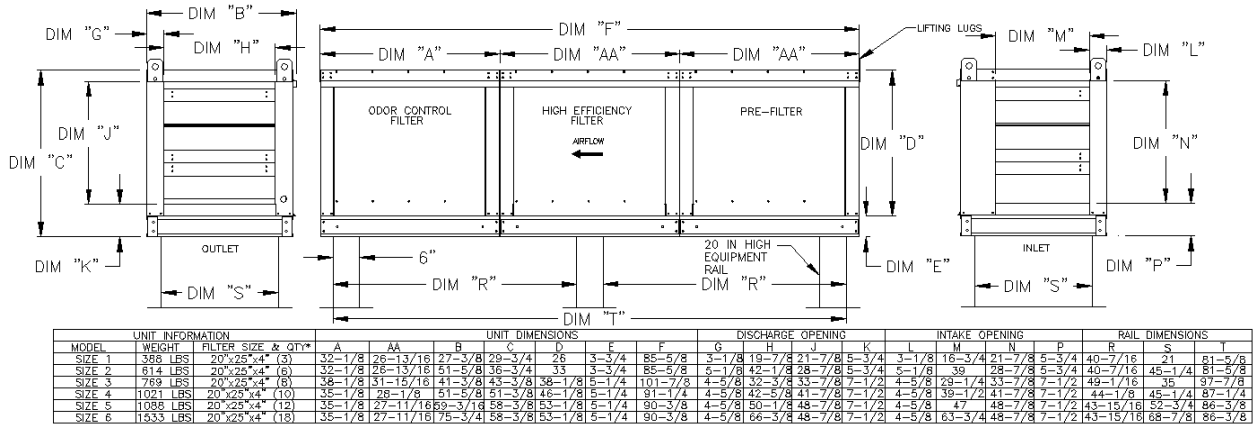

NOTE: For size 7 PCU, use the Auto Draw submittal for rail placement and dimensions.

Indoor (Inline) Installation (Typical)

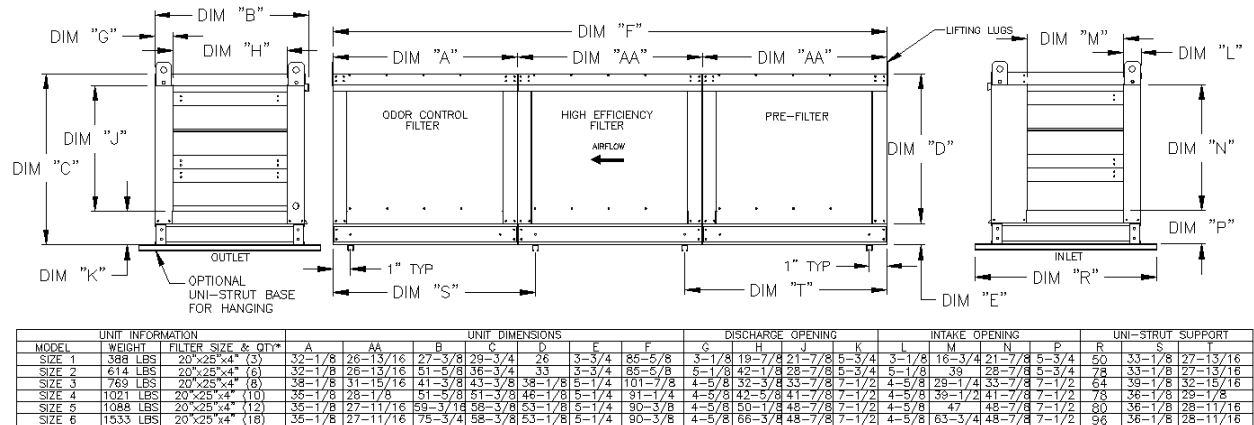

NOTE: For size 7 PCU, use the Auto Draw submittal for placement of uni-strut and dimensions.

Air Pressure Switch Option

Switches are preset from plant to .15" w.c. above the internal static pressure of the PCU with clean filters. Air pressure switch is located in downstream filter module. Route wiring from hood control panel to PCU using 1/2" conduit through quick seal located near lower right area of filter module containing switch. Use existing conduit in module to route wires from exterior of module to switch. Install wiring according to label above switch. Be sure all conduit fittings are tight. Once filters become clogged, switch closes illuminating light in kitchen. User should then clean or replace filters as required.

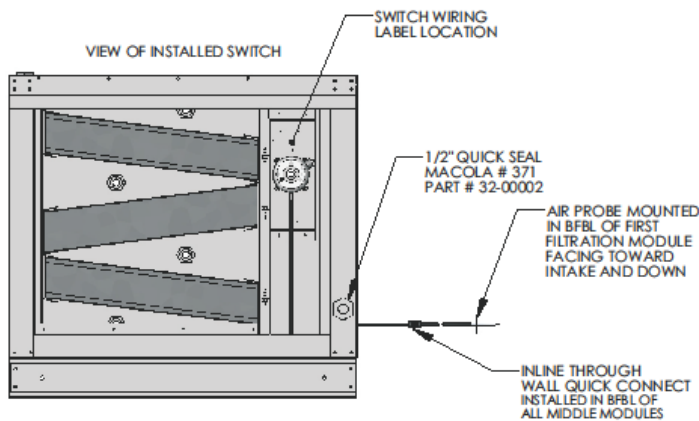
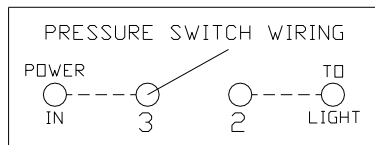

AIR LINE ROUTING NOT TO SCALE
FILL ALL BLANK HOLES IN BFBL WITH RIVETS

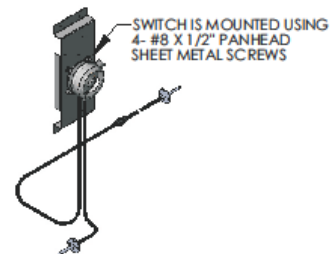

DIFFERENTIAL AIR PRESSURE SWITCH
SP = 1.8" MACOLA # 17047
PART #ADPS-03-1-N
SP > 1.8" MACOLA # 17049
PART #ADPS-05-1-N

SWITCH SET-POINT PER PCU PAPERWORK

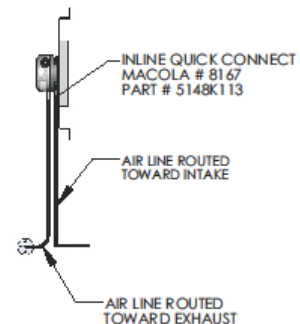
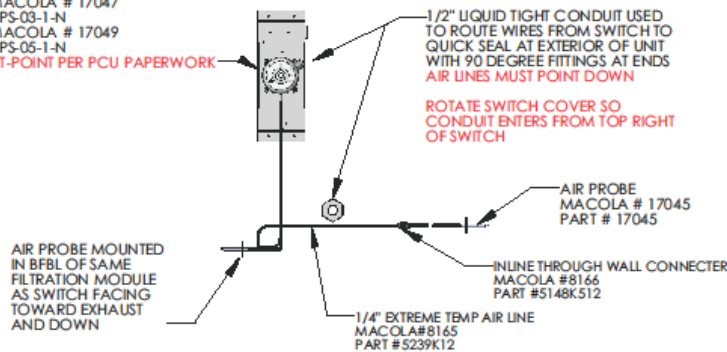

Advanced Filter Monitoring Option

The PCU Advanced Filter Monitoring Module (PCUAFM) utilizes proprietary algorithms to make determinations about filter loading percentages as well as fault conditions, such as missing filters and missing doors. These algorithms take into consideration known characteristics and interactions of many specific filter combinations, stored calibration values derived from measurements taken at the time of test and balance, and measurements of the dynamically changing current operating conditions such as demand ventilation. Personnel servicing the PCU have direct access to operating characteristics and fault conditions through the use of a LCD screen, which is conveniently located directly on the PCUAFM board. Accurate monitoring of PCU filter conditions not only ensures proper operation of the PCU, but can also reduce the operating cost of the PCU by reporting the condition of each individual filter module. This can eliminate the needless replacement of filters that have not yet reached the end of their useful life.



Features and Benefits:

- Monitors pressure drop across each filter module of the Pollution Control Unit (PCU).
- Detects Missing Filter and Missing Door condition.
- Detects Filter Clogged condition.

Several techniques are employed to ensure the validity of the pressure readings. Consequently disturbances caused by events such as fan starting and stopping, filter door removal and sudden changes in building or atmospheric pressure will cause a delay in updating the faults until the disturbances have subsided and enough fresh data has been gathered.

The filter monitoring system has 8 ports which are used based on the number of filter modules in the PCU assembly. The following chart shows the port connections used for different PCU configurations. PORT 7 is used only if the PCU assembly has a blower installed. The unused ports remain exposed to the space in the cabinet. Port 8 (Atmospheric Port) is used to measure ambient pressure, external to the PCU.

PCUFMM PORT CONNECTIONS								
No of PCU filter modules	PORT 1	PORT 2	PORT 3	PORT 4	PORT 5	PORT 6	PORT 7	PORT 8
1	YES	YES	NO	NO	NO	NO	YES/NO	YES
2	YES	YES	YES	NO	NO	NO	YES/NO	YES
3	YES	YES	YES	YES	NO	NO	YES/NO	YES
4	YES	YES	YES	YES	YES	NO	YES/NO	YES
5	YES	YES	YES	YES	YES	YES	YES/NO	YES

PCU AFM LCD Menus

Following are the various menus that appear in sequential order during navigation thru the LCD screen.

- **POLLUTION CTRL UNIT**
 - This screen shows up upon unit start up.
- **FILTER STATUS**
 - Displays percentage of filter clogging for up to 5 filter modules or "MISSING" if a module's filters are missing. "CALIBRATION REQUIRED" will be displayed if the calibration sequence has not been completed upon PCU unit start up.
- **PRESSURES**
 - Displays pressure drop for up to 5 filter modules, the total pressure drop (TOT) across the PCU, PCU inlet static (IN) and discharge pressure (OUT).
- **TEMPERATURE**
 - Temperature sensor on the circuit board displays relative temperature of the cabinet that houses the controls.
- **FAULTS**
 - The following are various faults that are displayed on the LCD screen. "NO FAULTS" are displayed if the PCU is functioning as desired.

"CALIBRATION REQUIRED"
"FILTER CLOGGED"
"FILTER MISSING"
"PCU CLOGGED"
"24 HOUR CLOG"
"MISSING DOOR"
"72 HOUR CLOG"

- **RESET FAULTS**
 - Once a fault is activated and the necessary corrected action is taken this menu choice is selected to clear the fault.
- **CALIBRATION**
 - A 4 digit PIN (1234) is entered using the board buttons. Once entered correctly the new filter calibration sequence is started. "CALIBRATING" will be displayed until calibration is complete. A percentage complete will also be displayed. **Fan speed must be maintained at 100% for the entire calibration time.** If fluctuations are detected the calibration sequence will restart from zero percent.
 - Calibration **MUST** be performed after PCU unit start up or with any PCU or Hood Filter configuration change. Calibration is **ALWAYS** performed with clean PCU filters.

- **CONFIGURATION**

- PCU is configured at the factory. PCU has to be re-configured **ONLY** if filter types in any filter module are changed.
- To Configure the PCU a 4 digit PIN (5678) is entered using the board buttons.

The following are the sub menus available

- **CFG. PCU MODULES**

- This sub menu steps through the process of configuration. Module count for the PCU assembly is entered followed by the filter type for each module.

- **PCU NUMBER**

- The number for this PCU will be displayed in reverse video and is selected using the board buttons. This number allows for up to 8 PCUs to exist on one Modbus network.

- **INLET PRESSURE VARIATION**

- This sub menu allows the user to adjust the variation in inlet pressure for faults to be detected by the PCU.
- The default parameter setting is 15%, i.e. if the pressure at the inlet of the PCU drops by more than 15% of the calibrated value due to changes in inlet conditions like Missing Hood Filters or Open Duct Access doors, all faults on the PCU except "MISSING DOOR" will be **IGNORED**.

- **EDIT CALIBRATION VALUES**

- This sub menu allows the user to change stored calibration values.
- Upper and lower limits for filter module pressures are set at 5.000" and 0.000".
- Upper and lower limits for inlet pressure are set at -0.001" to -5.000", and upper and lower limits for outlet pressures are set at 5.000" and -5.000".

- **EDIT DISCHARGE THRESHOLD**

- This sub menu allows the user to change the discharge threshold to help detect MISSING DOOR fault. Default value is set at 0.100".

The "INLET PRESSURE VARIATION" percentage, "EDIT CALIBRATION" and "DISCHARGE THRESHOLD" setting can be changed anytime without the need to recalibrate the unit.

- **INFORMATION**

- This menu displays filter type for up to 5 modules, software, revision, number of filter modules currently selected, calibration info for filter modules selected, inlet calibration value, discharge calibration value, inlet pressure variation setting and discharge threshold limit.

LCD Menu Tree

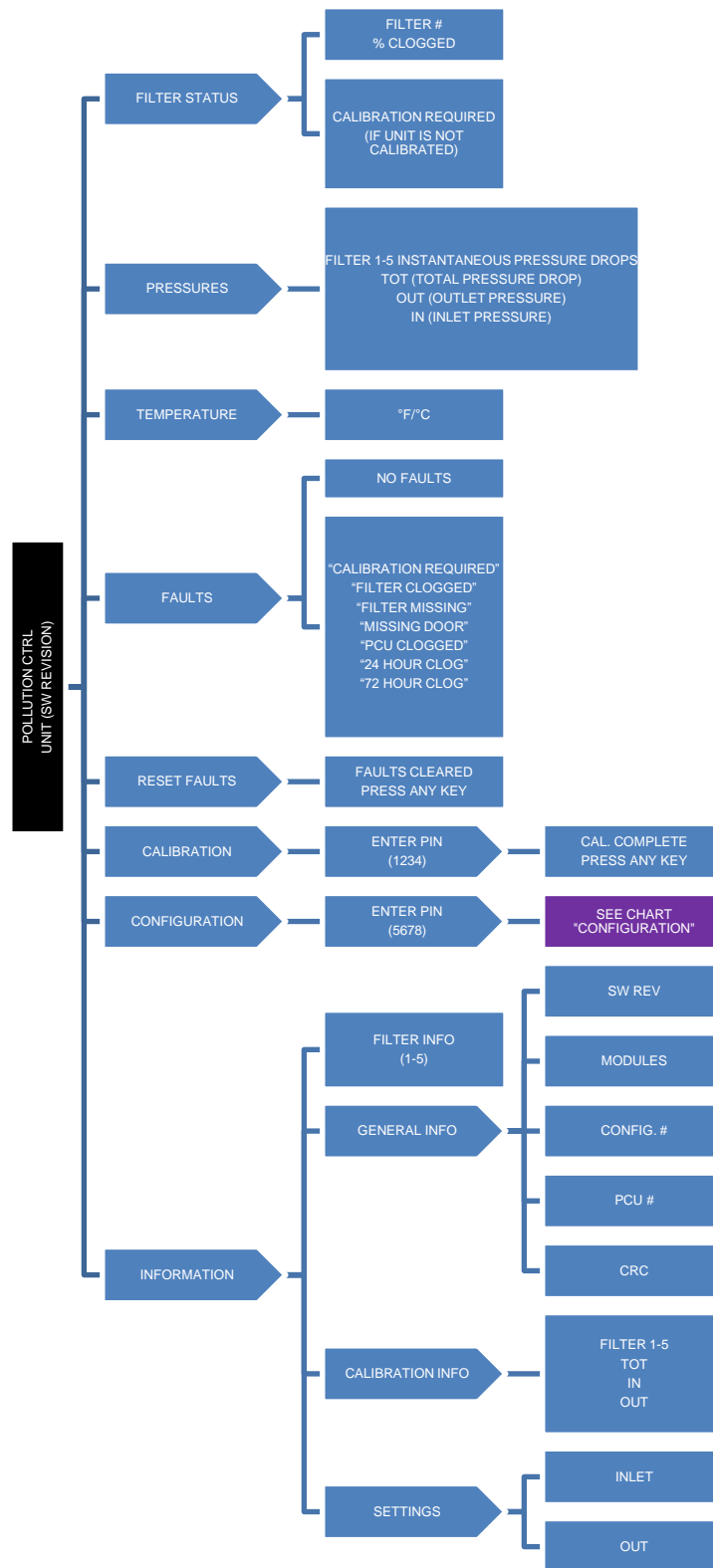

CONFIGURATION

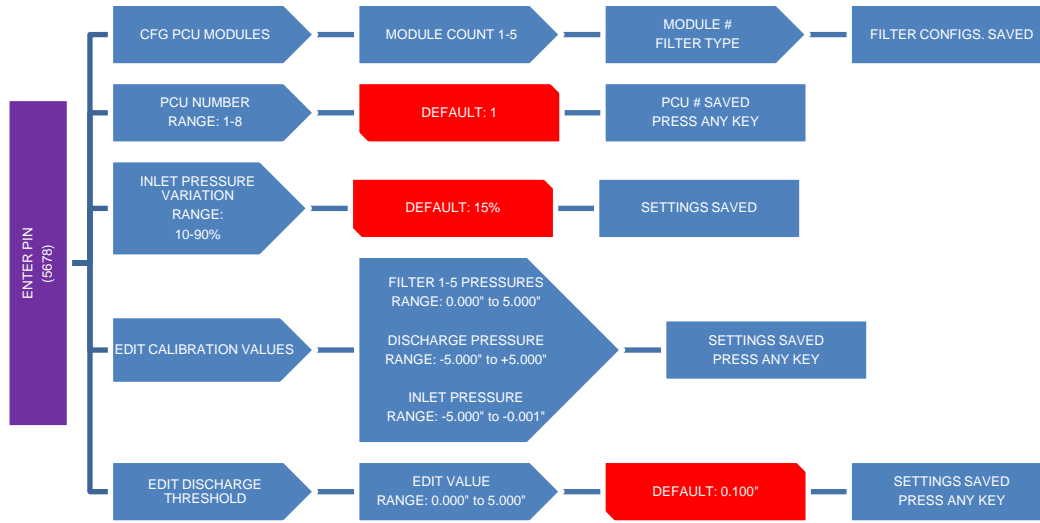

PCUAFM Wiring

Before connecting power to the control, read and understand the entire section of this document. As-built wiring diagrams are furnished with each control by the factory, and are attached either to the door of the unit or provided with the paperwork packet.

Electrical wiring and connections should be done in accordance with local ordinances and the National Electric Code, ANSI/NFPA 70. Be sure the voltage and phase of the power supply and the wire amperage capacity is in accordance with unit nameplate.

1. Always **disconnect power** before working on the PCUFMM. Lock and tag the disconnect switch to breaker to prevent accidental power up.
2. **120VAC** should be wired from terminals H1, N1 in the Electrical Control Package.
3. Make certain that the power source is compatible with the requirements of your equipment. The system wiring schematic identifies the **proper phase and voltage** of the equipment.
4. Before connecting control to power source, verify power line wiring is de-energized.
5. Do not kink the power cable and never allow the cable to come in contact with oil, grease, hot surfaces or chemicals.
6. Before powering up the system, make sure that the interior of the control is free of loose debris or shipping materials.

WARNING!!
Disconnect power before installing or servicing control. High voltage electrical input is needed for this equipment. This work should be performed by a qualified electrician.

Copper Wire Ampacity

Wire Size AWG	Maximum Amps
14	15
12	20
10	30
8	50
6	65
4	85

Fire System

Pollution Control Units often require a fire system to be installed with the PCU. CORE or Ansul R-102 Fire Suppression Systems are available for the PCU. PCU fire systems use fusible links or electric sensors set at 360°F to activate the fire system. Outdoor Ansul R-102 installations require a climate controlled cabinet to ensure the fire system does not drop below 32°F and does not exceed 130°F. See below for more information about outdoor installations. The Pollution Control Unit fire system must be interlocked with a hood fire system so that if the hood system activates, the PCU system activates. Reverse activation is required by code, and is recommended for safety. Details of this interlock can be found in the installation guide provided by the fire system manufacturer.

In the event that the fire system is accidentally activated, all disposable filters must be replaced and the pre-filter cleaned. The water or chemical agent used in the fire system can cause the filters to prematurely fail.

In the event that a fire occurs in the ductwork leading to the PCU or inside the PCU, the following must be completed. The unit must be cleaned of all fire suppression chemicals and grease. The filters must be replaced, this includes the pre-filter. If any of the gasketing is damaged, replace the gasketing between modules and between the doors. If any of the components that make-up the Pollution Control Unit are damaged by fire, then that component must be replaced and inspected by factory trained service personnel.

Installation, commissioning, or resetting of the fire system must be done by a licensed fire system installer, per the guidelines set forth by the fire system manufacturer.

Climate Controlled Utility Cabinet

For outdoor installations, a climate controlled cabinet is available to house the fire system. This box contains a heater, an exhaust fan, and thermostats to control the temperature inside the cabinet. The Utility Cabinet thermostats come preset to heat below 40° F and cool above 90° F. The climate controlled cabinet requires a dedicated 15 amp, 60 Hz, 115 volt, single phase electrical service.

Typical Wiring Schematic for the Climate Controlled Utility Cabinet

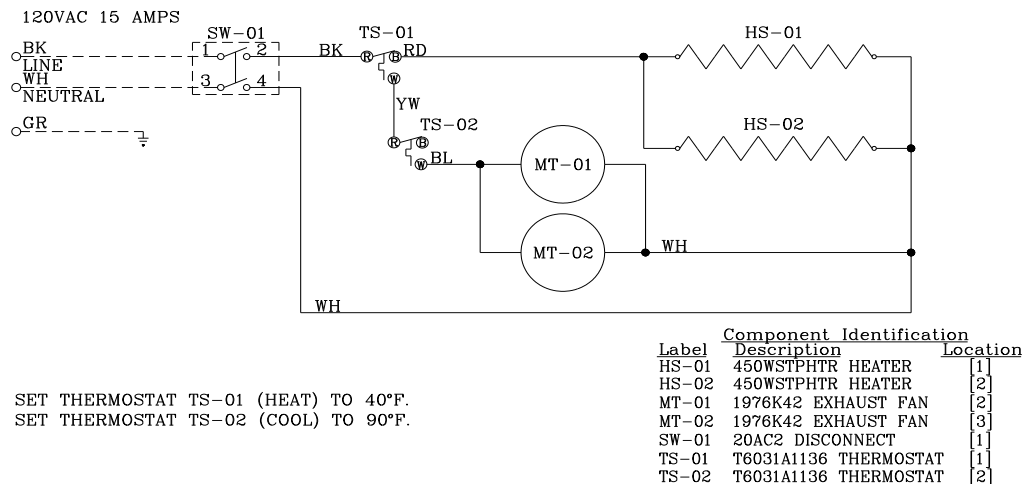

Pollution Control Unit with Climate Controlled Utility Cabinet Installed

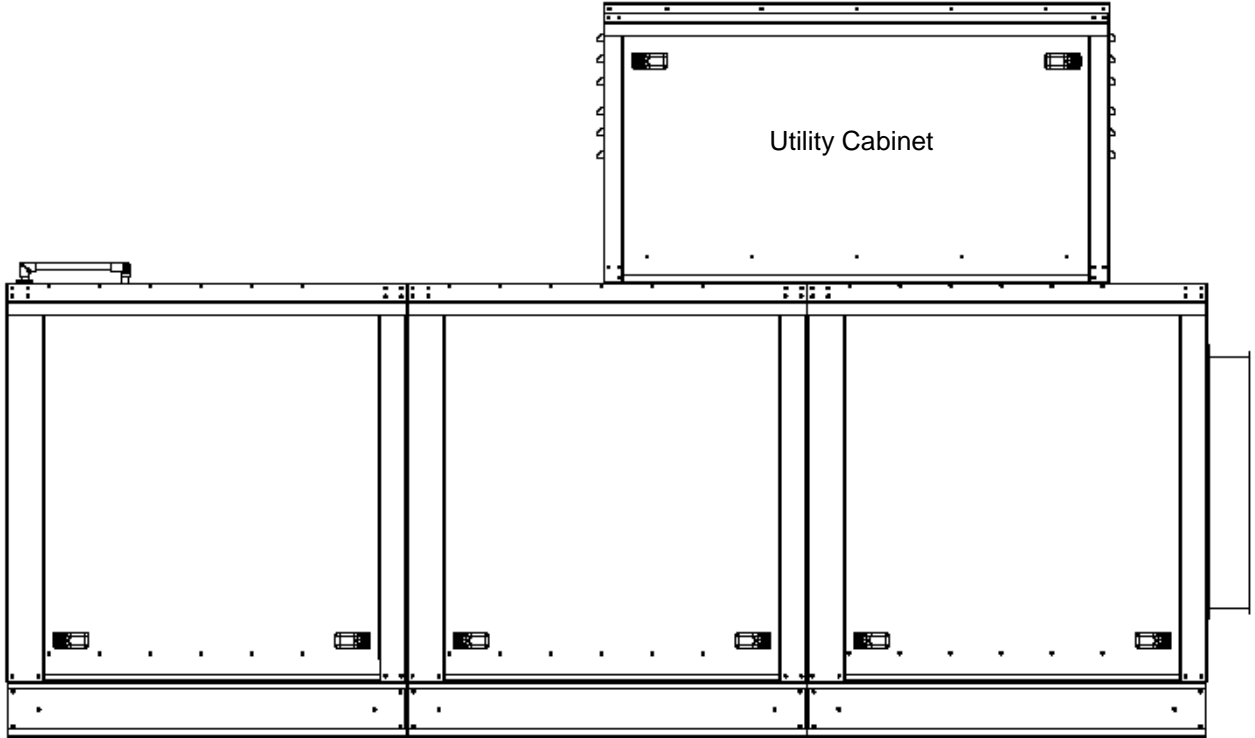

Bolted Door Design

A bolted door design is an optional construction version of the PCU to meet UL1978 requirements. The PCU bolted door design contains the following parts:

Description	Part Number
High Temp Ceramic (White) Gasket	397-91PSA
1/4 -20 Bolts	92323A525
Cage Nuts	11626-03224

High temperature ceramic gasket is applied on the door liner, around the door perimeter and door jambs. Prior to closing the door, make sure all cage nuts are installed. When the doors are closed, make sure the 1/4-20 bolts are installed. Torque the bolts to **45 in-lbs**.

Small Module



Last Module



OPERATION

Prior to starting up or operating the PCU, check all fasteners for tightness. In particular, check the module connection seal and the door seals. With power to the fan **OFF**, check the airflow direction of the filters as they must match the label on the filter.

Start Up

Special Tools Required

- 3M Fire Barrier 2000 + Silicone Sealant
- Standard Hand Tools

Start Up Procedure

1. Check all fasteners and connections for tightness.
2. Inspect the air-stream for obstructions and install filters if missing.
3. Filters must be installed in the correct direction.
4. Verify drain connections.
5. When the fan is started up, observe the operation and check for any unusual noises.
6. Inspect the entering and leaving ductwork connections. Ensure there are not leaks or pinholes in grease duct. Grease rated duct should be continuously welded to the PCU.
7. If unit is installed on vibration isolators, ensure that the isolators are adjusted correctly leaving plenty of spring force on the unit to absorb vibration.

Troubleshooting

The following tables list causes and corrective actions for possible problems with the pollution control units and the fan attached to the PCU. Review these lists prior to consulting manufacturer.

Troubleshooting Chart

Problem	Potential Cause	Corrective Action
Fan Motor Overload / Excessive Airflow	Filters not installed	Install all filters and unit doors
	Fan speed is too high	Reduce fan RPM
	Motor wired incorrectly	Check motor wiring to wiring diagram located on fan motor
	Overload in starter set too low	Set overload to motor FLA value
	Motor HP too low	Determine if HP is sufficient for job
	Duct static pressure lower than design	Reduce fan RPM
Insufficient Airflow	Fan rotating in the wrong direction	Be sure fan is rotating in the direction shown on rotation label
	Poor outlet conditions	There should be a straight clear duct at the outlet
	Duct static pressure higher than design	Improve ductwork to eliminate or reduce duct losses
	Blower speed too low	Increase fan RPM. Do not overload motor
	Dirty or clogged filters	Clean and/or replace
	Belt slippage	Adjust belt tension
Excessive Vibration and Noise	Misaligned pulleys	Align pulleys
	Damaged or unbalanced wheel	Replace wheel
	Fan is operating in the unstable region of the fan curve	Refer to performance curve for fan
	Bearings need lubrication or replacement	Lubricate or replace
	Fan speed is too high	Reduce fan RPM
	Belts too loose, worn or oily	Inspect and replace if needed
Check PCU filter light is ON	Air Pressure Switch Option	Clean and/ or replace filters Set switch to .15" w.c. above internal pressure of clean PCU
	Dirty or clogged filters	
	Switch set incorrectly	Increase switch setting by .1" w.c. See Fault Chart below
	Internal static pressure is higher than estimated	
	Advanced Filter Monitoring Option	
Fault shown on LCD screen		
Check PCU light does NOT come on	Light is burned out	Check light with jumper wire, check related wiring, replace/ repair if needed
	Switch is set incorrectly	Set switch to .15" w.c. above internal pressure of clean PCU
	Internal static pressure is lower than estimated	Decrease switch setting by .1" w.c.
Fan and Cooking Equipment will not operate	PCU Missing Door	See Fault Chart below
	PCU Missing Filters	
	PCU Filters Clogged for 72 hours	
Sounding of Audible Alarm	PCU filters clogged for 24 hours	Replace Clogged filters with clean filters of same type
Smoke/Odor leaking from PCU	Exhaust fan installed before PCU	Move exhaust fan to discharge side of the PCU

The following chart lists causes and corrective actions for possible faults shown on the LCD screen with the PCU. Review this list prior to consulting manufacturer.

Fault Chart

Fault	Potential Cause	Corrective Action
CALIBRATION REQUIRED	Unit not calibrated upon start up	Calibrate the PCU
	Unit taking too long to calibrate	Varying airflow at inlet of the PCU Check for blocked PORT 8 (Atmospheric port)
FILTER CLOGGED	Filters in a module are clogged	Replace filters in module showing "100% Clog" with clean filters of the same filter type
	Access door in duct left open	Close access door in duct
FILTER MISSING	Filters in a module are missing	Place filters back in Missing Filter module and check for missing filters in all other modules
	Hood filters are clogged	Clean filters in the hood
	Blocked Inlet to the PCU	Make sure nothing is blocking air flow entering the PCU
MISSING DOOR	Missing Door in one of the modules	Place door back in module having missing door and check for missing filters in each module
PCU CLOGGED	Pressure drop across entire PCU exceeds allowable limits	Replace filters in module showing maximum percentage clog with clean filters of same type
	Access door in duct left open	Close access door in duct
24 HOUR CLOG	Filters in a module are clogged for 24 hours	Replace filters in module showing "100% Clog" with clean filters of the same filter type
	Pressure drop across entire PCU exceeds allowable limits for 24 hours	Replace filters in module showing maximum percentage clog with clean filters of same type
	Access door in duct left open for 24 hours	Close access door in duct
72 HOUR CLOG	Filters in a module are clogged for 72 hours	Replace filters in module showing "100% Clog" with clean filters of the same filter type
	Pressure drop across entire PCU exceeds allowable limits for 72 hours	Replace filters in module showing maximum percentage clog with clean filters of same type
	Access door in duct left open for 72 hours	Close access door in duct

ATTENTION!!

In order to prevent erroneous issuing of fault conditions, the monitoring system takes several minutes to issue a fault.

FAULTS will not be detected if PCU is running outside Normal Hood operating conditions.

MAINTENANCE

To guarantee trouble free operation of this PCU, the manufacturer suggests following these guidelines. Most problems associated with PCU failures are directly related to poor service and maintenance such as not replacing or cleaning filters.

Please record any maintenance or service performed on this fan in the documentation section located at the end of this manual.

WARNING: DO NOT ATTEMPT MAINTENANCE ON THE PCU UNTIL THE ELECTRICAL SUPPLY HAS BEEN COMPLETELY DISCONNECTED FROM THE FAN.

General Maintenance

1. PCU doors and approaches to PCU should be kept clean and free from any obstruction.
2. Filters have a airflow direction associated with them. Pre-filters should be installed so drain holes are at the bottom edge of the filter. All other filters have an airflow direction sticker that must match the direction of airflow. See the picture below for this illustration and see table below for filter part numbers.
3. All fasteners should be checked for tightness each time maintenance checks are performed prior to restarting unit.
4. Ductwork and PCU should be cleaned according to code requirements.

Filter Information

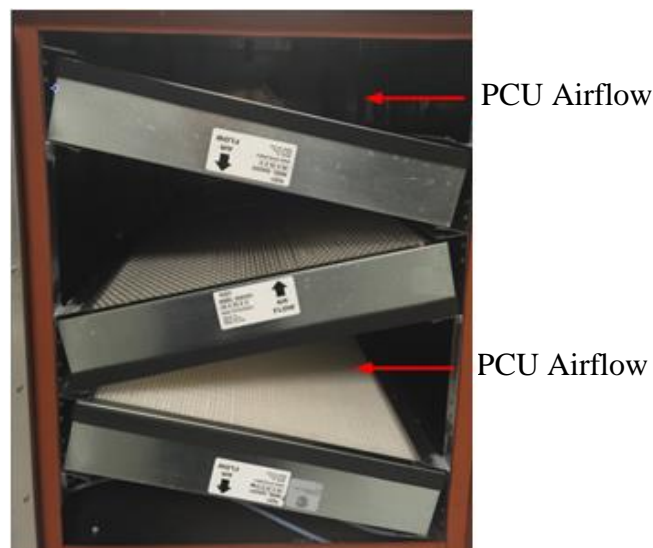

NOTE FILTERS INSTALLED WITH DIRECTION ARROW STICKERS MATCHING DIRECTION ARROW ON PCU FRAME ABOVE IS A SIZE 2 UNIT, V BANK AND NUMBER OF FILTERS WILL VARY FOR OTHER SIZES

WARNING: FILTER PART NUMBERS OUTLINED BELOW ARE LISTED FOR USE IN THE PCU. USING ANY OTHER FILTERS WILL VOID WARRANTY AND AFFECT PERFORMANCE

Standard Filter Part Numbers

PCU Module Size	20" x 25" x 4"	Captrate Solo Pre-Filter	High Efficiency (MERV 15)	Odor Control 100% Carbon
Size 1	3	CSF2025-NH	90802025	34-A0008192
Size 2	6	CSF2025-NH	90802025	34-A0008192
Size 3	8	CSF2520-NH	90802025	34-A0008192
Size 4	10	CSF2025-NH	90802025	34-A0008192
Size 5	12	CSF2025-NH	90802025	34-A0008192
Size 6	18	CSF2025-NH	90802025	34-A0008192
Size 7	30	CSF2025-NH	90802025	34-A0008192

Optional Pre Filter, High Efficiency, and HEPA Filter Part Numbers

PCU Module Size	20" x 25" x 4"	Grease Lock Combination Pre-Filter*	High Temperature High Efficiency Filter	Standard HEPA Filter
Size 1	3	GL2025/CSF	110-500-404	90812025
Size 2	6	GL2025/CSF	110-500-404	90812025
Size 3	8	GL2520/CSF	110-500-404	90812025
Size 4	10	GL2025/CSF	110-500-404	90812025
Size 5	12	GL2025/CSF	110-500-404	90812025
Size 6	18	GL2025/CSF	110-500-404	90812025
Size 7	30	GL2025/CSF	110-500-404	90812025

* Grease Lock Combination Pre Filter is a combination of Grease Lock Filter and Captrate Solo Filter

Grease Lock Filter Replacement	
PCU Size	Part Number
1,2,3,4,5,6,7	GL2025

Optional Odor Control Media Part Numbers

PCU Module Size	20" x 25" x 4"	Carbon / Permanganate Blend	100% Permanganate	Caustic Impregnated	Carbon / Permanganate Blend Panel	100% Carbon Panel	100% Permanganate Panel	Caustic Impregnated Panel
Size 1	3	34-A0007766	34-A0015408	34-A0015405	34-A0017097	34-A0017095	34-A0017098	34-A0017096
Size 2	6	34-A0007766	34-A0015408	34-A0015405	34-A0017097	34-A0017095	34-A0017098	34-A0017096
Size 3	8	34-A0007766	34-A0015408	34-A0015405	34-A0017097	34-A0017095	34-A0017098	34-A0017096
Size 4	10	34-A0007766	34-A0015408	34-A0015405	34-A0017097	34-A0017095	34-A0017098	34-A0017096
Size 5	12	34-A0007766	34-A0015408	34-A0015405	34-A0017097	34-A0017095	34-A0017098	34-A0017096
Size 6	18	34-A0007766	34-A0015408	34-A0015405	34-A0017097	34-A0017095	34-A0017098	34-A0017096
Size 7	30	34-A0007766	34-A0015408	34-A0015405	34-A0017097	34-A0017095	34-A0017098	34-A0017096

There are two types of gasket used in sealing the PCU. The orange gasket is used for weatherproofing the exterior seams between modules. It is rated at 450° F and has a PSA (Pressure Sensitive Adhesive) backing. The white gasket is a 1500° F degree gasket that is used to seal all internal joints in the PCU, including the doors, filter tracks, and inner perimeter between modules. Orange gasket is applied to the sides and White gasket is applied at the top of the filter access area to prevent infiltration. There is a double layer of gaskets between modules as shown below.

450° F Gasket between Modules and doors



1500° F Gasket for Internal Joints



Gasket Type Chart

Gasket Type	Application	Size	Temp Rating	Part Number
High Temp Closed Cell (Orange)	Exterior Seam Between Modules	¼" x 1"	450°F	SNS200A-1/4x1
High Temp Ceramic (White)	Internal Seams	¼" x 1"	1500°F	397-91PSA

2 Weeks After Startup

1. Inspect the unit and duct for grease or air leaks and repair leaks where required.
2. All fasteners and hardware should be checked for tightness each time maintenance checks are performed prior to restarting unit.
3. Monitor filter loading and determine the frequency that filters should be replaced. This will vary with the amount of contaminated effluent being filtered. Airflow will be affected (reduced) by filter loading. It is important that the pre-filter be cleaned on a regular basis and that the remaining filters be replaced when necessary to keep design airflow requirements.
4. Make necessary adjustments to air pressure switch to ensure proper function of indicator light.

Every Month

1. Inspect the unit and duct for grease or air leaks and repair leaks where required.
2. Filters need to be checked monthly for loading. If required, the filters either need to be cleaned or replaced. Filter change out may occur more often in severe conditions. Washable steel pre-filters can be washed in warm soapy water. When re-installing filters, be sure to install with the **airflow in the correct direction** as indicated on the filter or with drain holes on bottom edge of filter.

Duct Cleaning

1. Place tarp under PCU to catch overspray during cleaning.
2. Place tarp over Blower insulation and motor to prevent damage during cleaning.
3. Remove all tarps from Unit after cleaning is completed.

Yearly

1. Inspect all seals for wear and deterioration. Replace if necessary.
2. Inspect pre-filter for cleanliness. Replace if necessary.
3. Replace all secondary filtration and odor control media if necessary.
4. Inspect unit for leaks where ductwork is attached and in modules themselves. Repair where necessary

Start-Up and Maintenance Documentation

START-UP AND MEASUREMENTS SHOULD BE PERFORMED AFTER THE SYSTEM HAS BEEN AIR BALANCED (Warranty will be void without completion of this form)

Job Information

Job Number	
Address	
City	
State	
Zip	
Phone Number	
Fax Number	
Contact	
Purchase Date	

Service Company	
Address	
City	
State	
Zip	
Phone Number	
Fax Number	
Contact	
Start-Up Date	

PCU Information

Refer to the start-up procedure in this manual to complete this section.

Name Plate and Unit Information	
Model Number	
Serial Number	
Pressure Switch Set Point	

Advanced Filter Pressure Monitoring Information

Filter Module	Filter Type	Pressure
1		
2		
3		
4		
5		

Software Revision No	
Inlet Pressure	
Outlet Pressure	
Inlet Pressure Variation %	
Discharge Threshold	

Maintenance Record

Date	Service Performed

Date	Service Performed

Factory Service Department
 Phone: 1-866-784-6900
 Fax: 1-919-882-5204