

Grease Duct

CAPTIVE

Design Guide for

**FACTORY-WELDED
GREASE DUCT
SYSTEMS**

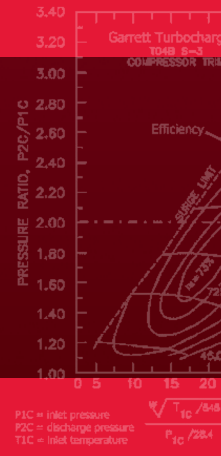
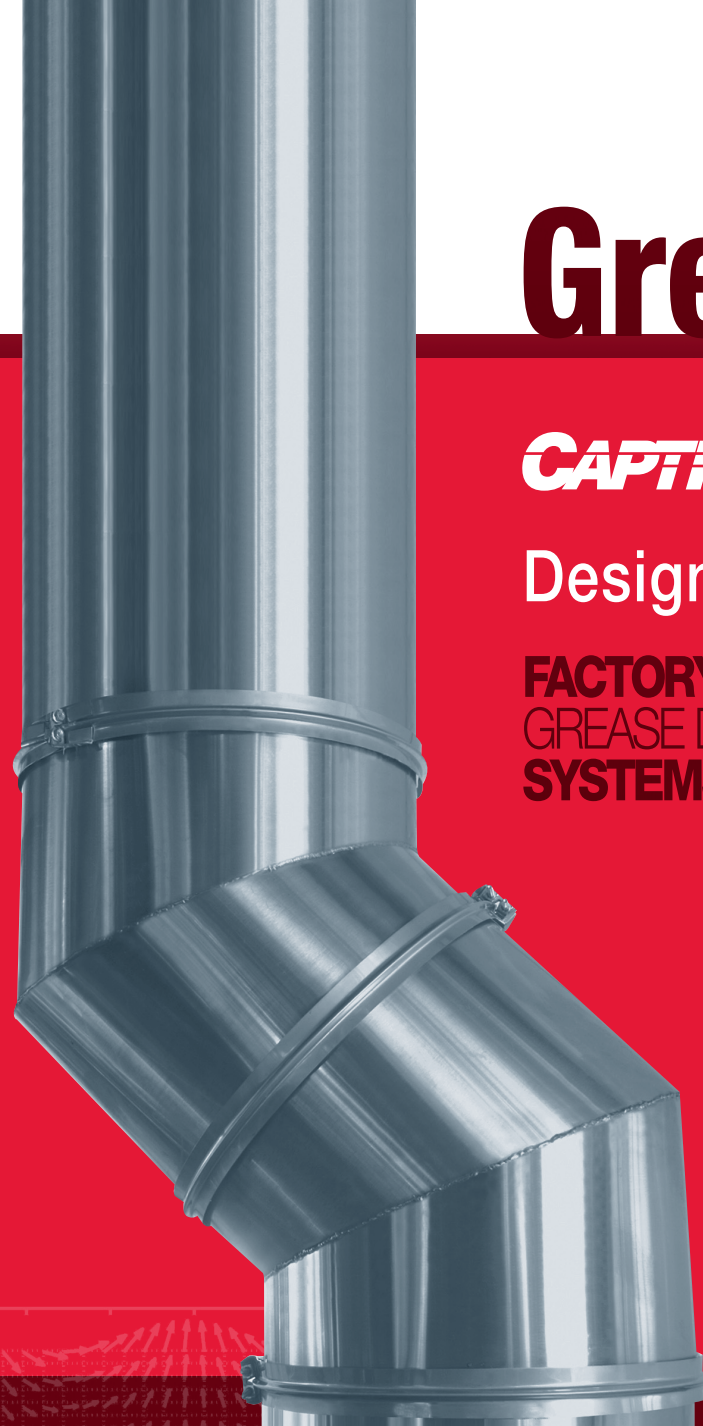

- Department of Education
 - Education & Culture Course
 - Educational Psychology Course
 - Preschool Education Course
 - Special Education Course
 - Japanese Course
 - Social Studies Course
 - English Course
 - Mathematics Course
 - Natural Science Course
 - Technology Course
 - Home Economics Course
 - Music Course
 - Art Course
 - Health & Physical Education Course
- Department of Information and Culture Course
 - System Information Course
- Department of Environmental Education
 - Attached Elementary School
 - Attached Junior High School
 - Attached School for Children with Mental Disabilities
 - Attached Kindergarten
 - Center for Educational Research and Development

- Department of Economics
- Department of Finance
- Department of Management
- Department of Accounting Information
- Department of Information Processing and Management
- Department of Social Systems
- Archival Museum
- Institute for Economic and Business Research
- Educational Center for Information Technology
- Center for Risk Research
 - School Education
 - Special Education
 - Subject Studies
 - Resource
 - Business Administration
 - Global Finance

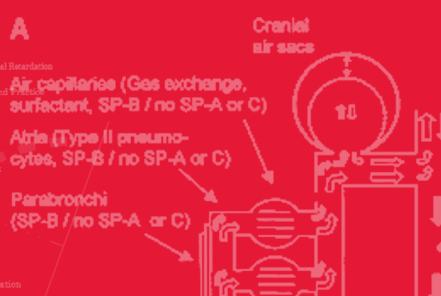

General Information

Product Overview

Grease duct is an ETL listed, single wall construction made from 430 stainless steel. Duct diameters range from 8" to 24", with multiple lengths and accessories available. Grease duct is ideal for use in kitchen ventilation applications and is available as a stand-alone system or part of a fully integrated package. Grease duct is pre-engineered for optimum performance for exhaust fans and hoods.

Grease duct is ETL listed to Standard UL-1978; duct does not have to be welded in the field.

General Notification

The purpose of the NFPA 96 Standard is to reduce the potential fire hazard of cooking operations, independent of the type of cooking equipment used and whether used in public or private facilities. Please refer to Chapter 7 of the NFPA 96 Standard, Exhaust Duct Systems, for detailed description of duct requirements and design.

All dimensions are shown in American Standard (feet and inches).

Table of Contents

01 General Information

- Product Overview
- General Notification

02 Table of Contents

03 Standards and Key Words

- References

04 Specifications

- Table 1- 3M Fire Barrier 2000 Plus Usage

05 Clearances

- Table 2- Clearance- Grease Duct
- Zero Clearances to Combustibles
- Duct Wrap Features

06 Designing Duct

- Types of Pressure Losses or Resistance to Flow
Component and Dynamic

07 Frictional Pressure

- Table 3- Required Air and Duct Values & Formulas
- Nomenclature
- Table 4- Part Type
- Table 5- Example Part Names

08 Design Considerations

- Table 6- Minimum Overlap
- Alignment & Bracing of Grease Duct
- Table 7- Horizontal Support Spacing

09 -Table 8- Vertical Support Spacing

- Duct Diameter Sizing

10 Grease Duct Components

- Factory Installed Riser

11 -Field Installed Riser

12 -Straight Duct

13 -Adjustable Straight Duct

14 -Table 9- Dynamic Loss Coefficient Table

15 -Adjustable Collar

16 -Adaptor

17 -Elbow- 90°

18 -Elbow- 45°

19 -Access Door Assembly

20 -Duct Tee

21 -Y Tee

22 -V Clamp Assembly

23 -Support Bracket

24 -Support Bracket Assembly

25 -Vertical Support Assembly

26 -Offset Collar

27 -Drain

28 -Transition Plate

29 -Notes

30 Appendix A- Duct Diameter Sizing Charts

- Duct Diameter: Transition Plates

40 Grease Duct Field Sheets

Standards & Key Words*

& References

UL- 1978 Test Standard for Safety Grease Ducts.

NFPA- 96 Standard for Ventilation Control and Fire Protection of Commercial Cooking Operations.

ETL- Edison Testing Laboratory, <http://www.intertek-etlsemko.com>. The ETL listed Mark is the legal equivalent of the UL Listed and CSA Listed Marks throughout the United States and Canada. ETL is a Nationally Recognized Testing Laboratory (NRTL) designated by the Occupational Safety and Health Administration (OSHA).

Access panel- A closure device used to cover an opening into a duct, an enclosure, equipment, or an appurtenance.

Authority Having Jurisdiction (AHJ)- An organization, office, or individual responsible for enforcing the requirements of a code or standard, or for approving equipment, materials, an installation, or a procedure.

Combustible Material- A material capable of undergoing combustion.

Factory-Built Grease Duct Enclosures- A listed factory-built grease duct system evaluated as an enclosure system for reduced clearances to combustibles and as an alternative to a duct with its fire-rated enclosure.

Grease Duct- A containment system for the transportation of air and grease vapors that is designed and installed to reduce the possibility of the accumulation of combustible condensation and the occurrence of damage if a fire occurs within the system.

Grease tight- Constructed and performing in such a manner as not to permit the passage of any grease under normal cooking conditions.

Fire wall- A wall separating buildings or subdividing a building to prevent the spread of the fire, and having a fire resistance rating and structural stability.

Non-combustible material- A material not capable of supporting combustion.

Thermal expansion- The tendency of matter to increase in volume or pressure when heated.

REFERENCES- 1NFPA 96, Standard for Ventilation Control and Fire Protection of Commercial Cooking Operations, 2004 Edition.

Specifications

Furnish single-wall, factory built, grease duct for use with Type 1 kitchen hoods, which conforms to the requirements of NFPA-96. Products shall be ETL listed to UL-1978 for venting air and grease vapors from commercial cooking operations as described in NFPA-96.

The duct wall shall be constructed of 430 stainless steel and be available in diameters 8” through 24”.

All supports, fan adapters, hood connections, fittings and expansion joints required to install grease duct shall be included.

Roof penetrations shall comply with listed clearance to combustibles. (See “Clearance to Combustibles” guide for details.) The grease duct will terminate at the fan adapter plate, will be fully welded to the fan adapter plate and the fan adapter plate will be fastened to the curb using a suitably sized fastener provided by others. (See “Operation, Installation, and Maintenance” manual [OIM] for details.)

Grease duct joints shall be held together by means of formed vee clamps and sealed with 3M Fire Barrier 2000+. Screws used to secure the vee clamps shall be of the hex-head type with flanged stops and tapered “lead in” threads for easy starting. Nuts shall be retained by means of a free-floating cage to allow easy alignment.

Single-Wall Grease Duct shall be installed in accordance with the manufacturer’s “Operation, Installation, and Maintenance Manual,” ETL listing and state and local codes.

Grease duct installed outside of the building shall be protected against accidental damage or vandalism.

Support vertically installed grease duct from the building structure using rigid structural supports. Anchor supports to the structure by welding or bolting steel expansion anchors or concrete inserts. Support horizontally installed grease duct from the building structure using above method or use Duct Mate, Wire Rope & Clutchers, part numbers WR20 & CL20. 1/2” threaded rod and saddles may also be used for the support of horizontal grease duct.

Fans shall be supported independently from the grease duct sections.

Table 1- 3M Fire Barrier 2000 Plus Usage

Duct Diameter	Duct Perimeter ft.	Average Feet Per Tube	Number of Joints Per Tube
8”	2.16’	30’	14
10”	2.68’	30’	11
12”	3.21’	30’	9
14”	3.73’	30’	8
16”	4.25’	30’	7
18”	4.78’	30’	6
20”	5.30’	30’	6
24”	6.35’	30’	5

The joint sealant used to seal all joint assemblies is a 3M product. 3M Fire Barrier 200 + Silicone Sealant is a ready-to-use, gun-grade, one-component silicone elastomer that cures upon exposure to atmospheric humidity to form a flexible seal. When installed properly, the sealant will control the spread of fire before, during and after exposure to open flames. No sealant substitutes may be used. (Reference OIM for Grease Duct to obtain additional information.)

Clearances

This grease duct is primarily intended for use in non-combustible surroundings, when installed in a room where enclosure is not required. Where the duct does not require an enclosure, it must have a minimum clearance to adjacent combustible walls as shown above in **Table 2**. If the enclosure fire rating is not rated as above or if the clearance listed in **Table 2** can not be maintained, then the duct system must be insulated using ZERO CLEARANCE TO COMBUSTIBLE CONSTRUCTION listed insulation.

Diameter	Clearance to Combustibles	Clearance to Limited Combustibles	Clearance to Non-combustibles
8"	18"	3"	0"
10"	18"	3"	0"
12"	18"	3"	0"
14"	18"	3"	0"
16"	18"	3"	0"
18"	18"	3"	0"
20"	18"	3"	0"
24"	18"	3"	0"

Duct Wrap Features

- 01** Zero clearance to combustibles.
- 02** One layer wrap for grease ducts rated as an enclosure alternative.
- 03** High strength and flexibility for installation ease.
- 04** Foil encapsulated with unique center overlap seams.
- 05** Stitched edges.
- 06** Safe fiber construction.
- 07** Mold resistant.

We recommend using the Thermal Ceramics Duct Wrap 2x2+, which is a foil-encapsulated, non-combustible, inorganic, flexible fireproofing wrap specifically tested and designed to provide a 1 or 2 hour fire rated enclosure for commercial kitchen grease ducts in compliance with AC 101 grease duct test standard. Also available is the 3M Fire Barrier Duct Wrap 15A & 20A. 3M Fire Barrier Duct Wrap is a fire resistant wrap consisting of a patented inorganic blanket encapsulated with reinforced foil.

Designing Duct

Types of Pressure Losses or Resistance to Flow

Pressure loss is the loss of total pressure in a duct or fitting. There are three important observations that describe the benefits of using total pressure for duct calculation and testing rather than using only static pressure.

- 01** Only total pressure in duct work always drops in the direction of flow. Static or dynamic pressures alone do not follow this rule.
- 02** The measurement of the energy level in an air stream is uniquely represented by total pressure only. The pressure losses in a duct are represented by the combined potential and kinetic energy transformation, i.e., the loss of total pressure.
- 03** The fan energy increases both static and dynamic pressure. Fan ratings based only on static pressure are partial, but commonly used.

Pressure loss in duct work has three components, frictional losses along duct walls, dynamic losses in fittings and component losses in duct-mounted equipment:

Component Pressure- Due to physical items with known pressure drops, such as hoods, filters, louvers, or dampers.

Dynamic Pressure- Dynamic losses are the result of changes in direction and velocity of air flow. Dynamic losses occur whenever an air stream makes turns, diverges, converges, narrows, widens, enters, exits, or passes dampers, gates, orifices, coils, filters, or sound attenuators. Velocity profiles are reorganized at these places by the development of vortices that cause the transformation of mechanical energy into heat. The disturbance of the velocity profile starts at some distance before the air reaches a fitting. The straightening of a flow stream ends some distance after the air passes the fitting. This distance is usually assumed to be no shorter than six duct diameters for a straight duct. Dynamic losses are proportional to dynamic pressure and can be calculated using the equation:

$$\rightarrow \text{Dynamic Loss Static Pressure} = (\text{Loss coefficient}) * (\text{Velocity pressure})$$

Where the local loss coefficient, known as a C-coefficient, represents flow disturbances for particular fittings or for duct-mounted equipment as a function of their type and ratio of dimensions. Coefficients can be found in this document or the ASHRAE Fittings diagrams database.

A local loss coefficient can be related to different velocities; it is important to know which part of the velocity profile is relevant. The relevant part of the velocity profile is usually the highest velocity in a narrow part of a fitting cross section or a straight/branch section in a junction.

Frictional Pressure

Frictional losses in duct sections are result from air viscosity and momentum exchange among particles moving with different velocities. These losses also contribute negligible losses or gains in air systems unless there are extremely long duct runs or there are significant sections using flex duct.

Friction loss and dynamic loss need to be calculated for a grease duct.

→ *Duct static pressure = friction loss + dynamic loss.*

Table 3- Required Air and Duct Values & Formulas	
Required Air and Duct Values	Formulas
Q = Air Flow Rate, Units = CFM	
D = Duct Diameter, Units = Feet	
A = Duct Cross Sectional Area, Units = Feet Squared	$A = \pi * (D/2)^2$
V = Air Velocity, Units = Feet/Minute	$V = Q/A$
VP = Velocity Pressure	$VP = (V/4005)^2$
L = Center Line Distance, Units = Feet	
C = Dynamic Loss Coefficient	Found in Tables below
SPF = Friction Loss Static Pressure	$SPF = .0195 * (L/D) * VP$
SPD = Dynamic Loss Static Pressure	$SPD = C * (VP)$
SP = Static Pressure	$SP = SPF + SPD$

Nomenclature- Grease duct parts are identified by a part type and part name. (Below)

Table 4- Part Type	
LT= straight duct	AD= access door
AJD= adjustable duct	TEASY= tee assembly
AC= adjustable clamp for adjustable duct	ADIB= access door inside blank
CLASY= v clamp assembly	TEAD= tee assembly access door
RISER= riser	ASY= assembly in 45° and 90°
FRISER= field riser	ADP = adaptor
RERI= retaining ring for field riser	VESU= vertical support
TP= transition plate	SUBR= support bracket- horizontal
C2D= offset collar	

Table 5- Example Part Names	
Example- DW0847LT	Example- DW1290ASY
DW= duct work	DW= duct work
08= duct diameter in inches	12= duct diameter in inches
47=duct length in inches	90= duct elbow turn angle in degrees
LT= straight duct	ASY= assembly

Design Considerations

When using adjustable duct sections within the duct horizontally or vertically, the minimum overlap required between the adjustable duct and the standard duct depends on the duct diameter (**Table 6**).

Diameter	Minimum Overlap for Adjustable Duct
8"	4"
10"	5"
12"	6"
14"	6"
16"	6"
18"	6"
20"	6"
24"	6"

Alignment & Bracing of Grease Duct

Grease duct has the characteristics of a continuous stainless steel pipe and it will expand and contract along its entire length with changes in its temperature. For this reason, conventional methods of attaching guides and braces to the outer wall of the grease duct cannot be used. Correctly installed support rings, saddles and wall guide assemblies will serve to keep the duct aligned, provide for adequate resistance to lateral loads and allow the free axial expansion and contraction movement. A simplified rule for duct expansion is that the axial growth will be approximately 1 inch per 100 feet of pipe length for each 100 degrees Fahrenheit the exhaust vapor temperature is above the surrounding air temperature.

Horizontal duct installation requires the use of horizontal supports rings. See **Table 7** for the spacing between supports when hung horizontally.

Diameter	Horizontal Support Spacing
8"	10'
10"	10'
12"	10'
14"	10'
16"	10'
18"	10'
20"	10'
24"	10'

Vertical duct installation requires the use of a wall supports. See **Table 8** for the spacing between the supports when hung vertically.

Table 8- Vertical Support Spacing	
Diameter	Vertical Support Spacing (feet)
8"	10'
10"	10'
12"	10'
14"	10'
16"	10'
18"	10'
20"	10'
24"	10'

Duct Diameter Sizing

The velocity of the air moving through grease rated duct work must comply with NFPA 96, IMC and local standards. The Duct Diameter Sizing Charts may be of assistance and are located in **Appendix A**.

> **Downloadable PDF version located at:** <http://www.captiveaire.com/ductsizing>

Factory Installed Riser

Grease Duct Components

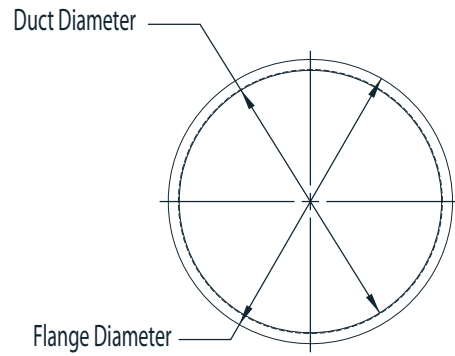
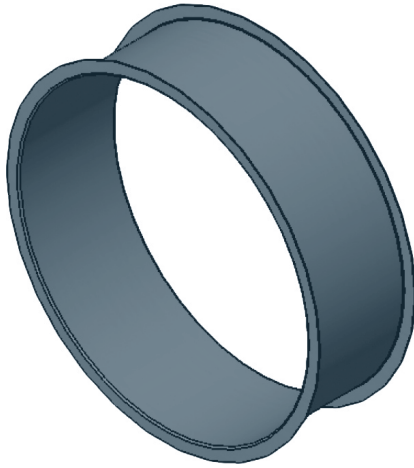

Notes:

Duct Information Table					
Duct Diameter	Duct Flange Diameter	Duct Area	Weight	Part Number	Dynamic Loss Coefficient
8"	9"	0.349 SF	1.486 lbs	DW08RISER	0.017
10"	11"	0.545 SF	1.789 lbs	DW10RISER	0.013
12"	13"	0.785 SF	2.142 lbs	DW12RISER	0.011
14"	15"	1.069 SF	2.495 lbs	DW14RISER	0.010
16"	17"	1.396 SF	2.848 lbs	DW16RISER	0.008
18"	19"	1.767 SF	3.201 lbs	DW18RISER	0.006
20"	21"	2.182 SF	3.554 lbs	DW20RISER	0.005
24"	25"	3.142 SF	4.260 lbs	DW24RISER	0.004

Field Installed Riser

Grease Duct Components

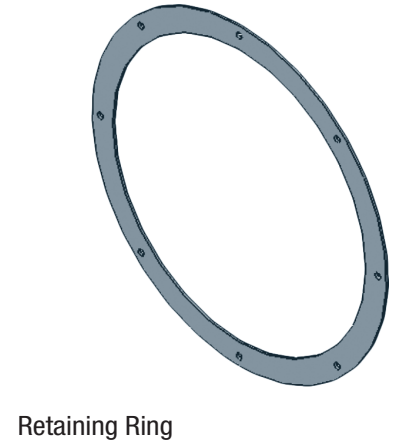
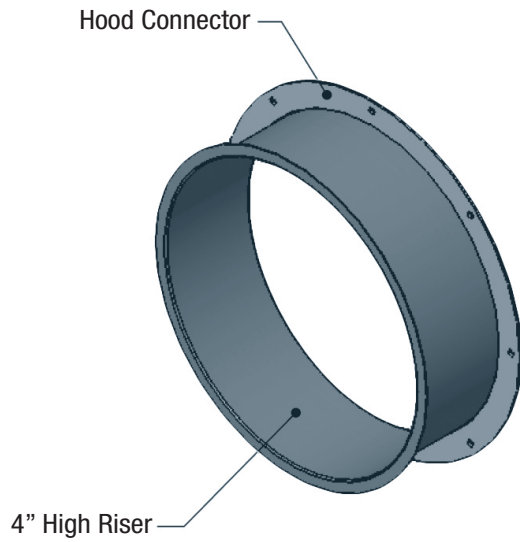

Notes:

For Installation and Instructions, reference OIM manual for Grease Duct.

Duct Information Table					
Duct Diameter	Duct Flange Diameter	Duct Area	Weight	Part Number	Dynamic Loss Coefficient
8"	9"	0.349 SF	1.863 lbs	DW08FRISER	0.017
10"	11"	0.545 SF	2.310 lbs	DW10FRISER	0.013
12"	13"	0.785 SF	2.758 lbs	DW12FRISER	0.011
14"	15"	1.069 SF	3.205 lbs	DW14FRISER	0.010
16"	17"	1.396 SF	3.652 lbs	DW16FRISER	0.008
18"	19"	1.767 SF	4.100 lbs	DW18FRISER	0.006
20"	21"	2.182 SF	4.547 lbs	DW20FRISER	0.005
24"	25"	3.142 SF	5.442 lbs	DW24FRISER	0.004

Straight Duct

Grease Duct Components

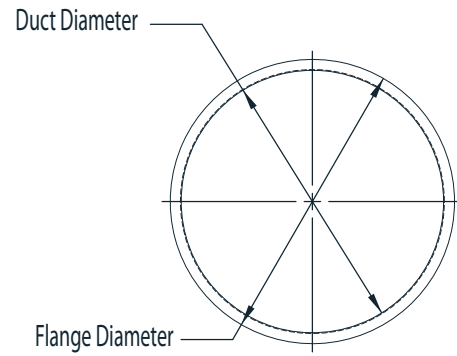
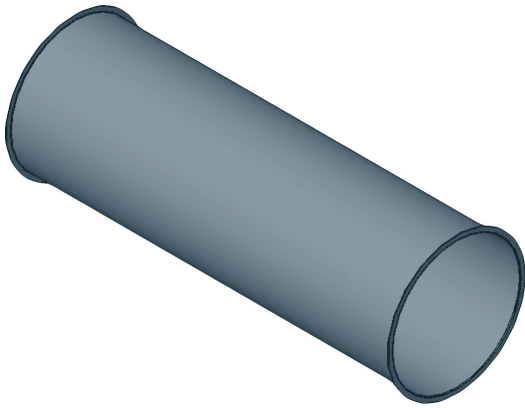

Notes:

For Dynamic Loss Coefficients, reference Table 9 on page 14 of the Duct Design Guide.

Duct Information Table						
Duct Diameter	Duct Flange Diameter	Duct Area	Part Number	Part Number	Part Number	Part Number
8"	9"	0.349 SF	DW0823LT	DW0829LT	DW0847LT	N/A
10"	11"	0.545 SF	DW1023LT	DW1029LT	DW1047LT	N/A
12"	13"	0.785 SF	DW1223LT	DW1229LT	DW1247LT	DW1259LT
14"	15"	1.069 SF	DW1423LT	DW1429LT	DW1447LT	DW1459LT
16"	17"	1.396 SF	DW1623LT	DW1629LT	DW1647LT	DW1659LT
18"	19"	1.767 SF	DW1823LT	DW1829LT	DW1847LT	DW1859LT
20"	21"	2.182 SF	DW2023LT	DW2029LT	DW2047LT	DW2059LT
24"	25"	3.142 SF	DW2423LT	DW2429LT	DW2447LT	DW2459LT

Adjustable Straight Duct

Grease Duct Components

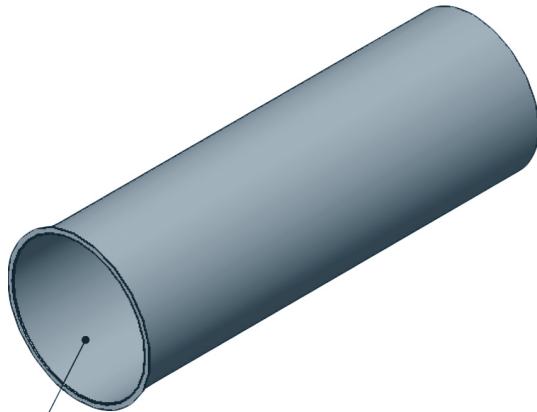

Adjustable Duct
Flanged One End Only

Notes:

For Dynamic Loss Coefficients, reference
Table 9 on page 14 of the Duct Design Guide.

Duct Information Table						
Duct Diameter	Duct Flange Diameter	Duct Area	Part Number	Part Number	Part Number	Part Number
7.828"	8.828"	0.349 SF	DW0824AJD	DW0830AJD	DW0848AJD	N/A
9.828"	10.828"	0.545 SF	DW1024AJD	DW1030AJD	DW1048AJD	N/A
11.828"	12.828"	0.785 SF	DW1224AJD	DW1230AJD	DW1248AJD	DW1260AJD
13.828"	14.828"	1.069 SF	DW1424AJD	DW1430AJD	DW1448AJD	DW1460AJD
15.828"	16.828"	1.396 SF	DW1624AJD	DW1630AJD	DW1648AJD	DW1660AJD
17.828"	18.828"	1.767 SF	DW1824AJD	DW1830AJD	DW1848AJD	DW1860AJD
19.828"	20.828"	2.182 SF	DW2024AJD	DW2030AJD	DW2048AJD	DW2060AJD
23.828"	24.828"	3.142 SF	DW2424AJD	DW2430AJD	DW2448AJD	DW2460AJD

Table 9- Dynamic Loss Coefficient Table

Table 9- Dynamic Loss Coefficient Table								
Straight Duct, Adjustable Duct, Riser Dynamic Loss Coefficient Table								
Length (Inches)	Diameter (Inches)							
	8	10	12	14	16	18	20	24
4	0.017	0.013	0.011	0.010	0.008	0.006	0.005	0.004
5	0.021	0.017	0.014	0.012	0.010	0.007	0.006	0.005
6	0.025	0.020	0.017	0.014	0.013	0.008	0.008	0.006
7	0.029	0.023	0.019	0.017	0.015	0.010	0.009	0.007
8	0.033	0.027	0.022	0.019	0.017	0.011	0.010	0.008
9	0.038	0.030	0.025	0.021	0.019	0.013	0.011	0.009
10	0.042	0.033	0.028	0.024	0.021	0.014	0.013	0.010
11	0.046	0.037	0.031	0.026	0.023	0.015	0.014	0.011
12	0.050	0.040	0.033	0.029	0.025	0.017	0.015	0.013
13	0.054	0.043	0.036	0.031	0.027	0.018	0.016	0.014
14	0.058	0.047	0.039	0.033	0.029	0.019	0.018	0.015
15	0.063	0.050	0.042	0.036	0.031	0.021	0.019	0.016
16	0.067	0.053	0.045	0.038	0.033	0.022	0.020	0.017
17	0.071	0.057	0.047	0.041	0.035	0.024	0.021	0.018
18	0.075	0.060	0.050	0.043	0.038	0.025	0.023	0.019
19	0.079	0.063	0.053	0.045	0.040	0.026	0.024	0.020
20	0.084	0.067	0.056	0.048	0.042	0.028	0.025	0.021
21	0.088	0.070	0.058	0.050	0.044	0.029	0.026	0.022
22	0.092	0.073	0.061	0.052	0.046	0.031	0.028	0.023
23	0.096	0.077	0.064	0.055	0.048	0.032	0.029	0.024
24	0.100	0.080	0.067	0.057	0.050	0.033	0.030	0.025
25	0.104	0.084	0.070	0.060	0.052	0.035	0.031	0.026
26	0.109	0.087	0.072	0.062	0.054	0.036	0.033	0.027
27	0.113	0.090	0.075	0.064	0.056	0.038	0.034	0.028
28	0.117	0.094	0.078	0.067	0.058	0.039	0.035	0.029
29	0.121	0.097	0.081	0.069	0.061	0.040	0.036	0.030
30	0.125	0.100	0.084	0.072	0.063	0.042	0.038	0.031
31	0.129	0.104	0.086	0.074	0.065	0.043	0.039	0.032
32	0.134	0.107	0.089	0.076	0.067	0.044	0.040	0.033
33	0.138	0.110	0.092	0.079	0.069	0.046	0.041	0.034
34	0.142	0.114	0.095	0.081	0.071	0.047	0.043	0.035
35	0.146	0.117	0.097	0.084	0.073	0.049	0.044	0.036
36	0.150	0.120	0.100	0.086	0.075	0.050	0.045	0.038
37	0.154	0.124	0.103	0.088	0.077	0.051	0.046	0.039
38	0.159	0.127	0.106	0.091	0.079	0.053	0.048	0.040
39	0.163	0.130	0.109	0.093	0.081	0.054	0.049	0.041
40	0.167	0.134	0.111	0.095	0.084	0.056	0.050	0.042
41	0.171	0.137	0.114	0.098	0.086	0.057	0.051	0.043
42	0.175	0.140	0.117	0.100	0.088	0.058	0.053	0.044
43	0.180	0.144	0.120	0.103	0.090	0.060	0.054	0.045
44	0.184	0.147	0.122	0.105	0.092	0.061	0.055	0.046
45	0.188	0.150	0.125	0.107	0.094	0.063	0.056	0.047
46	0.192	0.154	0.128	0.110	0.096	0.064	0.058	0.048
47	0.196	0.157	0.131	0.112	0.098	0.065	0.059	0.049
48	0.200	0.160	0.134	0.115	0.100	0.067	0.060	0.050

Adjustable Collar

Grease Duct Components



Notes:

For Installation and Instructions,
reference OIM manual for Grease Duct.

Duct Information Table			
Duct Diameter	Duct Flange Diameter	Duct Area	4" Collar Assembly
8"	9"	0.349 SF	DW0804AC
10"	11"	0.545 SF	DW1004AC
12"	13"	0.785 SF	DW1204AC
14"	15"	1.069 SF	DW1404AC
16"	17"	1.396 SF	DW1604AC
18"	19"	1.767 SF	DW1804AC
20"	21"	2.182 SF	DW2004AC
24"	25"	3.142 SF	DW2404AC

Adaptor

Grease Duct Components

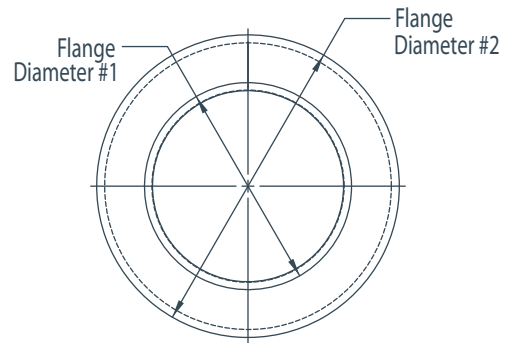
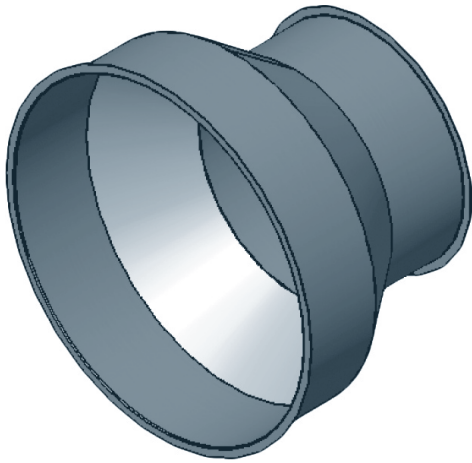

Notes:

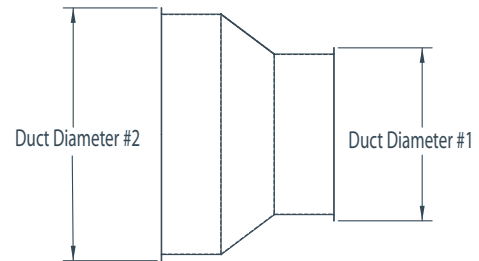

Duct Information Table									
Adapter Diameter	Flange Diameter #1	Flange Diameter #2	Duct Diameter #1	Duct Area	Duct Diameter #2	Duct Area	Weight	Part #	Dynamic Loss Coefficient
8x12	9"	13"	8"	0.349 SF	12"	0.785 SF	5.00 lbs	DW0812ADP	0.797
10x14	11"	15"	10"	0.545 SF	14"	1.069 SF	6.00 lbs	DW1014ADP	0.470
12x18	13"	19"	12"	0.785 SF	18"	1.767 SF	7.50 lbs	DW1218ADP	0.797
14x20	15"	21"	14"	1.069 SF	20"	2.182 SF	8.50 lbs	DW1420ADP	0.552
16x24	17"	25"	16"	1.396 SF	24"	3.142 SF	10.50 lbs	DW1624ADP	0.797

Elbow- 90°

Grease Duct Components

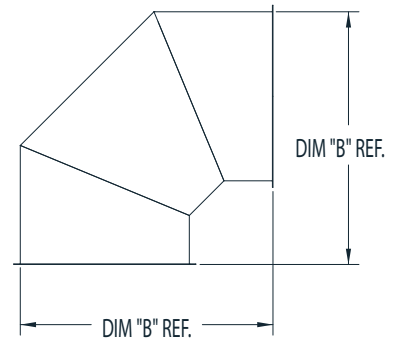
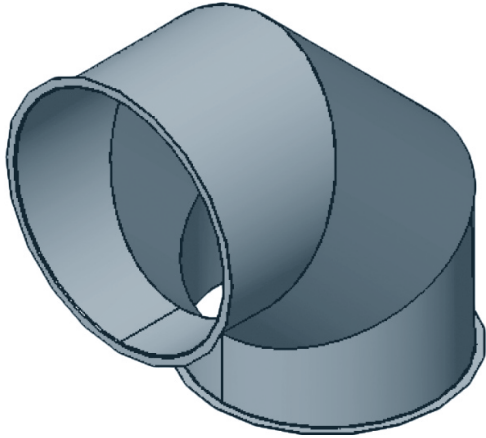

Notes:

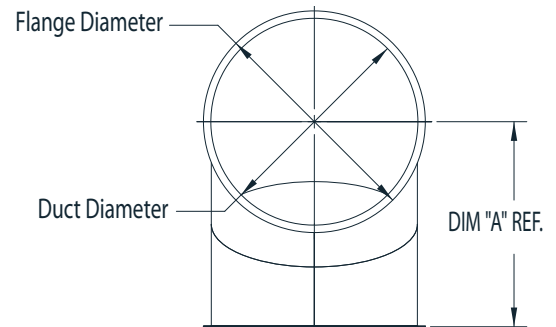

Duct Information Table							
Duct Diameter	Duct Flange Diameter	Duct Area	DIM "A"	DIM "B"	Weight	Part Number	Dynamic Loss Coefficient
8"	9"	0.349 SF	10"	14"	5.50 lbs	DW0890ASY	0.400
10"	11"	0.545 SF	11"	16"	7.50 lbs	DW1090ASY	0.420
12"	13"	0.785 SF	12"	18"	9.50 lbs	DW1290ASY	0.440
14"	15"	1.069 SF	13"	20"	11.50 lbs	DW1490ASY	0.460
16"	17"	1.396 SF	14"	22"	14.50 lbs	DW1690ASY	0.480
18"	19"	1.767 SF	15"	24"	17.50 lbs	DW1890ASY	0.500
20"	21"	2.182 SF	16"	26"	20.50 lbs	DW2090ASY	0.520
24"	25"	3.142 SF	18"	30"	27.50 lbs	DW2490ASY	0.540

Elbow- 45°

Grease Duct Components

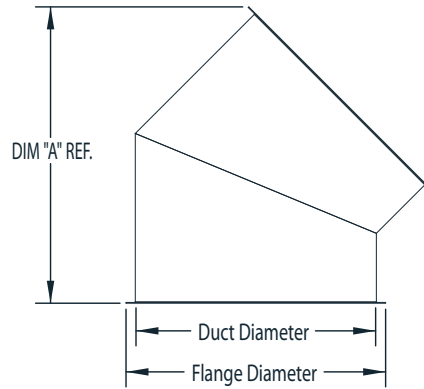
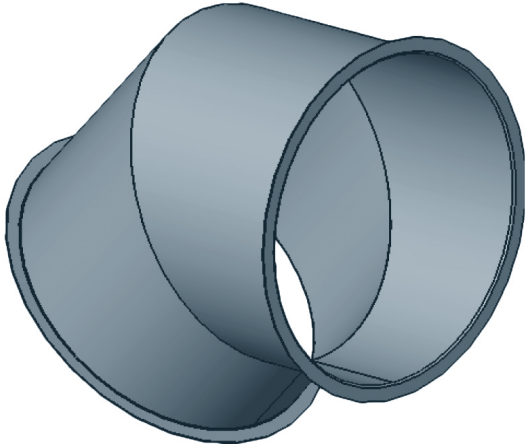

Notes:

Duct Information Table						
Duct Diameter	Duct Flange Diameter	Duct Area	DIM "A"	Weight	Part Number	Dynamic Loss Coefficient
8"	9"	0.349 SF	12.000"	3.50 lbs	DW0845ASY	0.150
10"	11"	0.545 SF	13.425"	4.50 lbs	DW1045ASY	0.150
12"	13"	0.785 SF	14.839"	5.50 lbs	DW1245ASY	0.150
14"	15"	1.069 SF	16.254"	7.00 lbs	DW1445ASY	0.150
16"	17"	1.396 SF	17.667"	8.50 lbs	DW1645ASY	0.150
18"	19"	1.767 SF	19.082"	10.00 lbs	DW1845ASY	0.150
20"	21"	2.182 SF	20.496"	12.00 lbs	DW2045ASY	0.150
24"	25"	3.142 SF	23.325"	15.50 lbs	DW2445ASY	0.150

Access Door Assembly

Grease Duct Components

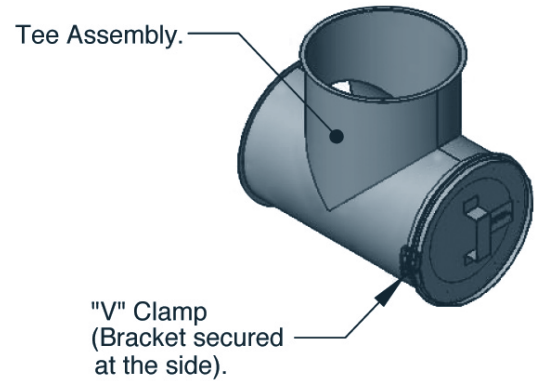
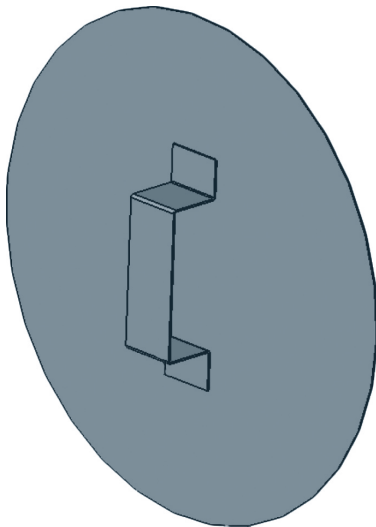

Notes:

For Installation and Instructions,
reference OIM manual for Grease Duct.

Duct Information Table					
Duct Diameter	Weight	Assembly Part #	Inside Blank Part #	Access Door Part #	V Clamp Part #
8"	8.00 lbs	DW08TEAD	DW08ADIB	DW0809AD	DW08CLASY
10"	11.00 lbs	DW10TEAD	DW10ADIB	DW1011AD	DW10CLASY
12"	14.00 lbs	DW12TEAD	DW12ADIB	DW1213AD	DW12CLASY
14"	15.00 lbs	DW14TEAD	DW14ADIB	DW1415AD	DW14CLASY
16"	18.00 lbs	DW16TEAD	DW16ADIB	DW1617AD	DW16CLASY
18"	23.00 lbs	DW18TEAD	DW18ADIB	DW1819AD	DW18CLASY
20"	28.00 lbs	DW20TEAD	DW20ADIB	DW2021AD	DW20CLASY
24"	33.00 lbs	DW24TEAD	DW24ADIB	DW2425AD	DW24CLASY

Duct Tee

Grease Duct Components

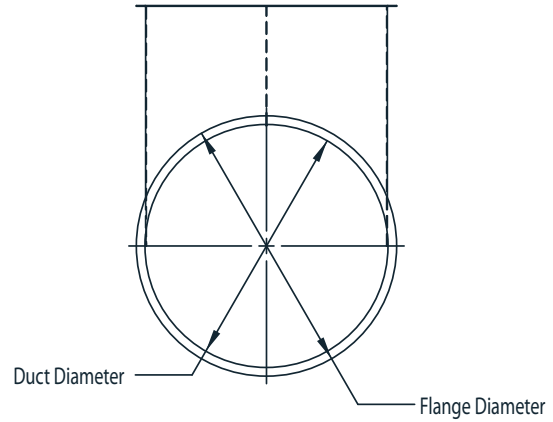
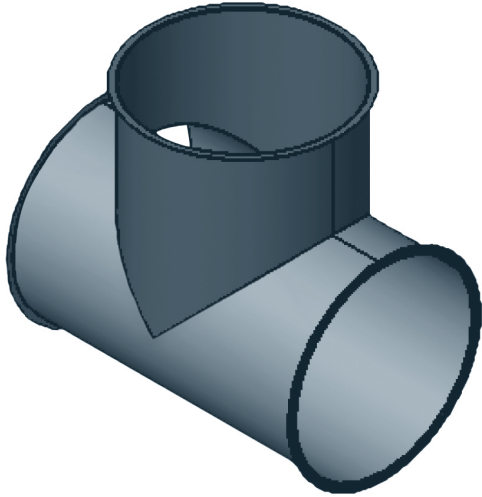

Notes:

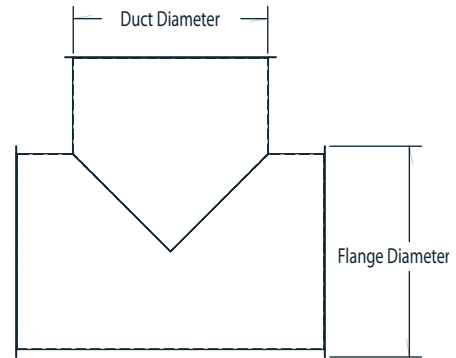

Duct Information Table					
Duct Diameter	Duct Flange Diameter	Duct Area	Weight	Part Number	Dynamic Loss Coefficient
8"	9"	0.349 SF	6.201 lbs	DW08CLASY	1.250
10"	11"	0.545 SF	8.364 lbs	DW10CLASY	1.250
12"	13"	0.785 SF	10.777 lbs	DW12CLASY	1.250
14"	15"	1.069 SF	13.439 lbs	DW14CLASY	1.250
16"	17"	1.396 SF	16.351 lbs	DW16CLASY	1.250
18"	19"	1.767 SF	19.512 lbs	DW18CLASY	1.250
20"	21"	2.182 SF	22.923 lbs	DW20CLASY	1.250
24"	25"	3.142 SF	30.494 lbs	DW24CLASY	1.250

Y Tee

Grease Duct Components

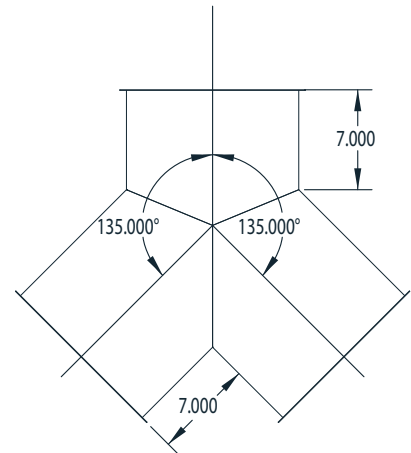
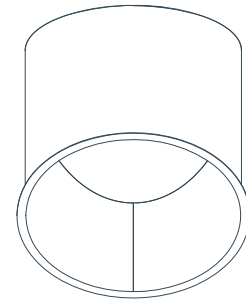
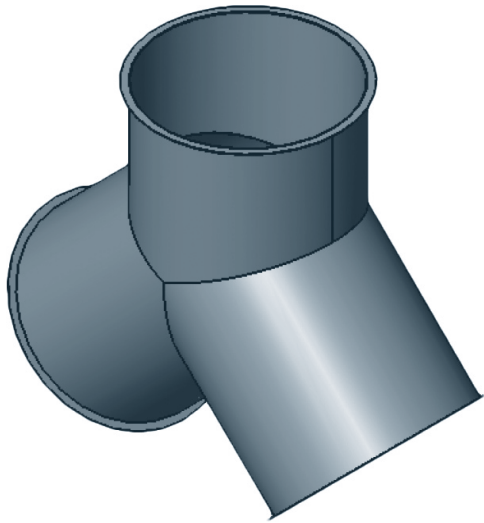

Notes:

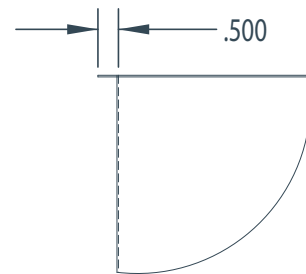
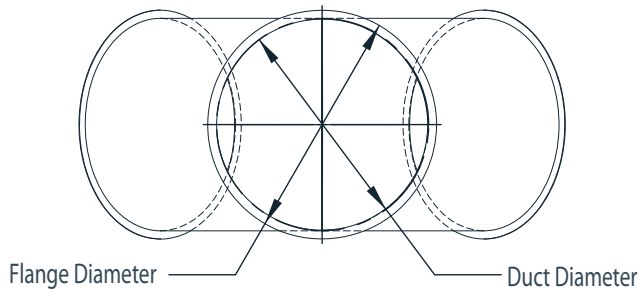

Duct Information Table

Duct Diameter	Duct Flange Diameter	Duct Area	Weight	Part Number	Dynamic Loss Coefficient
12"	13"	0.785 SF	13.122 lbs	DW12YTEASY	0.600
14"	15"	1.069 SF	15.932 lbs	DW14YTEASY	0.600
18"	19"	1.767 SF	22.094 lbs	DW18YTEASY	0.600
20"	21"	2.182 SF	25.446 lbs	DW20YTEASY	0.600
24"	25"	3.142 SF	32.692 lbs	DW24YTEASY	0.600

V Clamp Assembly

Grease Duct Components

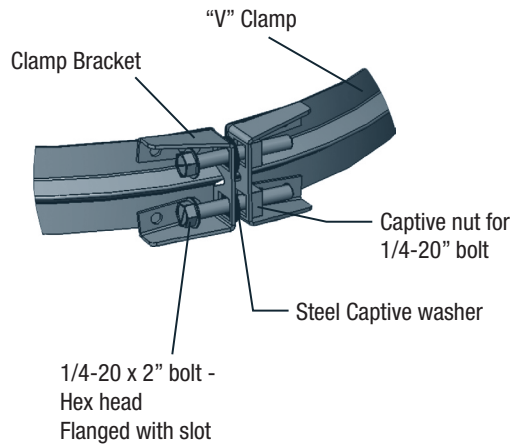
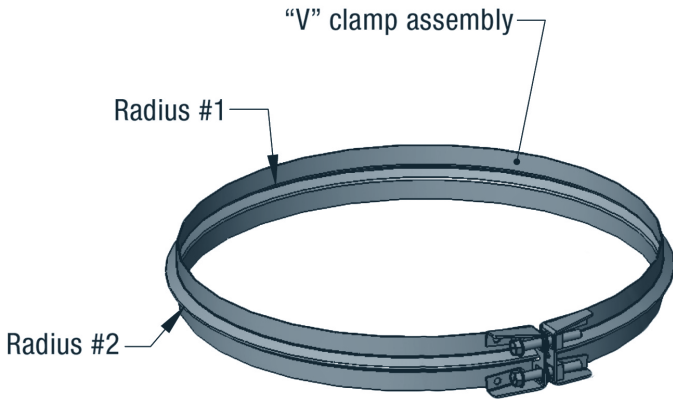

Notes:

Duct Information Table	
Duct Diameter	Part Number
8"	DW08CLASY
10"	DW10CLASY
12"	DW12CLASY
14"	DW14CLASY
16"	DW16CLASY
18"	DW18CLASY
20"	DW20CLASY
22"	DW24CLASY

Support Bracket

Grease Duct Components

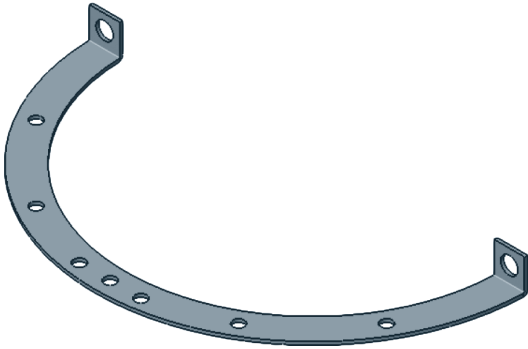

Notes:

Duct Information Table		
Duct Diameter	Weight	Part Number
8"	.499 lbs	DW08SUBR
10"	.603 lbs	DW10SUBR
12"	.708 lbs	DW12SUBR
14"	.812 lbs	DW14SUBR
16"	.916 lbs	DW16SUBR
18"	1.021 lbs	DW18SUBR
20"	1.125 lbs	DW20SUBR
24"	1.334 lbs	DW24SUBR

Support Bracket Assembly

Grease Duct Components

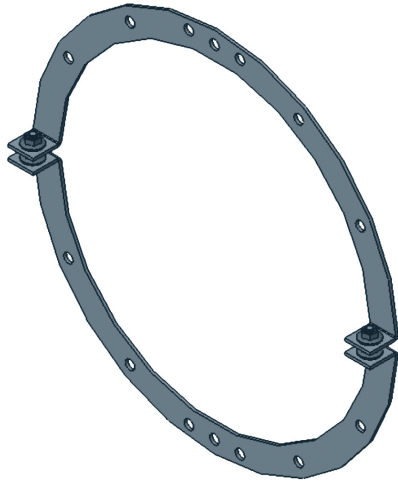

Notes:

Duct Information Table		
Duct Diameter	Weight	Part Number
8"	5.08 lbs	DW08SUBRASY
10"	7.04 lbs	DW10SUBRASY
12"	9.32 lbs	DW12SUBRASY
14"	11.92 lbs	DW14SUBRASY
16"	14.84 lbs	DW16SUBRASY
18"	18.08 lbs	DW18SUBRASY
20"	21.64 lbs	DW20SUBRASY
24"	29.74 lbs	DW24SUBRASY

Vertical Support Assembly

Grease Duct Components

Assembled by others during installation

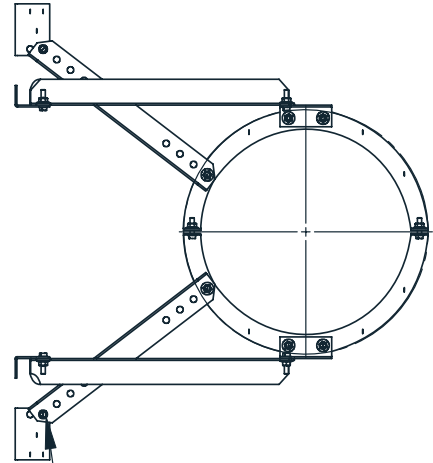
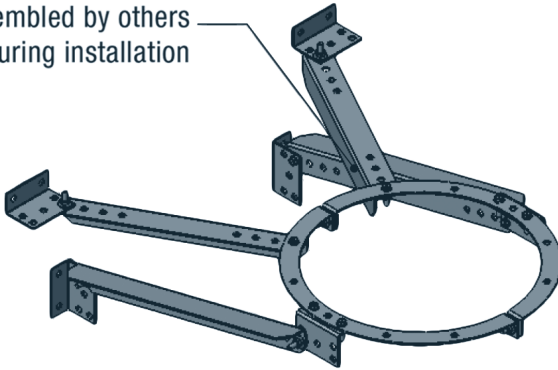

5/16-18 Hardware Used For Assembly.

Notes:

For Installation and Instructions, reference OIM manual for Grease Duct.

Duct Information Table		
Duct Diameter	Weight	Part Number
8"	10.778 lbs	DW08VESU
10"	10.986 lbs	DW10VESU
12"	11.196 lbs	DW12VESU
14"	11.404 lbs	DW14VESU
16"	11.612 lbs	DW16VESU
18"	11.822 lbs	DW18VESU
20"	12.000 lbs	DW20VESU
24"	12.500 lbs	DW24VESU

Offset Collar

Grease Duct Components

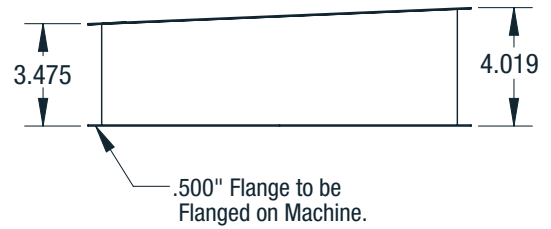
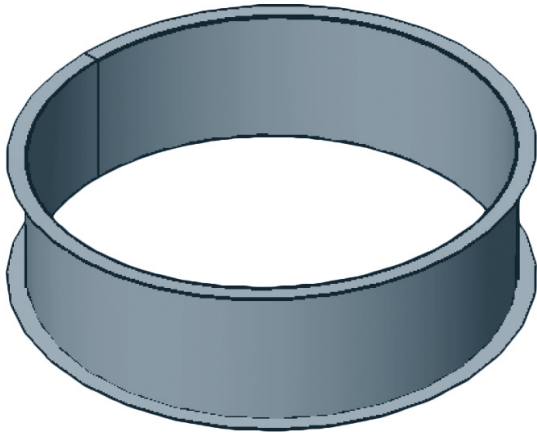

Notes:

Duct Information Table				
Duct Diameter	Duct Range Diameter	Duct Area	Weight	Part Number
8"	9"	0.349 SF	1.432 lbs	DW0804C2D
10"	11"	0.545 SF	1.772 lbs	DW1004C2D
12"	13"	0.785 SF	2.121 lbs	DW1204C2D
14"	15"	1.069 SF	2.471 lbs	DW1404C2D
16"	17"	1.396 SF	2.734 lbs	DW1604C2D
18"	19"	1.767 SF	3.052 lbs	DW1804C2D
20"	21"	2.182 SF	3.355 lbs	DW2004C2D
24"	25"	3.142 SF	4.081 lbs	DW2404C2D

Drain

Grease Duct Components

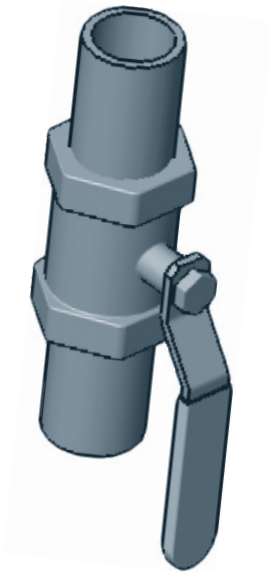

Notes:

For Installation and Instructions,
reference OIM manual for Grease Duct.

Duct Information Table		
Part Name	Duct Range	Part Number
1" Drain	8-14"	DWDRAIN1.0
1.5" Drain	16-24"	DWDRAIN1.5

Transition Plate

Grease Duct Components

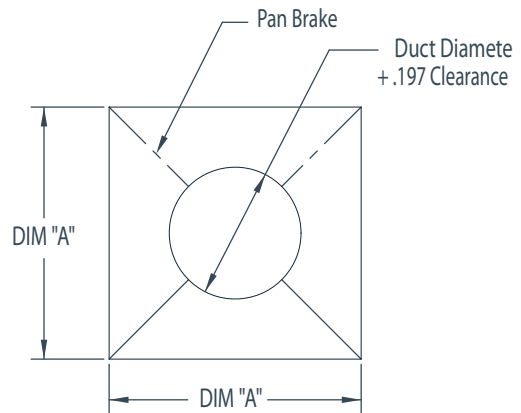
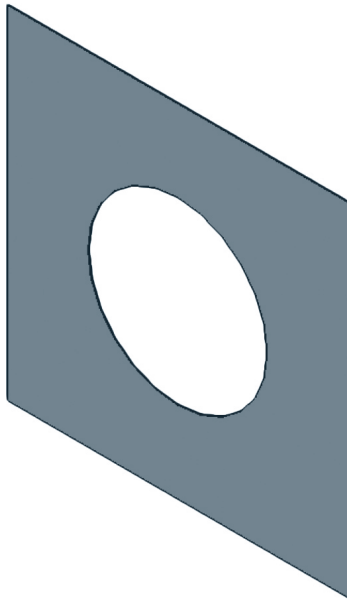

Notes:

Transition plate welded to adjustable or standard duct sections at the factory.

Example:
Used on a 17-1/2" curb
actual size is 19-1/2" plate
will be cut to size in field

Duct Information Table				
Wheel Diameter	Min CFM	Max CFM	Curb Square	DIM "A"
11"	400	1800	19 1/2	21 1/2
13"	600	2400	19 1/2	21 1/2
15"	1000	3800	23	25
18"	1500	5500	26 1/2	28 1/2
20"	1700	6700	26 1/2	28 1/2
24"	2500	11500	31 1/2	33 1/2
30"	3000	14000	38 1/2	40 1/2
DU/DR10	0	500	17 1/2	19 1/2
DU/DR12	50	750	17 1/2	19 1/2
11"	100	900	19 1/2	21 1/2
11"	450	1250	19 1/2	21 1/2
11"	400	1300	19 1/2	21 1/2
13"	600	2100	19 1/2	21 1/2
15"	700	2500	23	25
15"	800	3400	23	25

Notes

Appendix A- Duct Diameter Sizing Charts

The following is needed to determine the duct diameter: CFM and Velocity ($CFM / V = AREA$). Charts listed below show what duct diameter to use given a CFM and Velocity. Title information for each block identifies the name of the fan(s), the curb size and the duct transition part number(s) needed to transition from the listed duct to the curb. Duct is sized to the fan inlet and curb, under-sizing or over-sizing duct will cause system effect and or interfere with the curb. Transition plates are oversized to allow for slight misalignments in duct, transition plates are cut to size in the field. **Note: the highlighted area in each chart identifies the specific duct diameter(s) to be used per the charts titled fan.**

Duct Diameter: Transition Plates

NCA08FA – NCA10FA - DU25HFA, DU30HFA, DU33HFA, DU50HFA - Curb 19 1/2" - Transition Plates DW1912TP & DW1914TP							
	Velocity						
CFM	1200	1300	1400	1500	1600	1700	1800
700	12	10	10	10	10	10	10
800	12	12	12	10	10	10	10
900	12	12	12	12	12	10	10
1000	14	12	12	12	12	12	12
1100	14	14	14	12	12	12	12
1200	14	14	14	14	12	12	12
1300	16	14	14	14	14	12	12
1400	16	16	14	14	14	14	12
1500	16	16	16	14	14	14	14
1600	16	16	16	14	14	14	14
1700	18	16	16	16	14	14	14
1800	18	16	16	16	16	14	14
1900	18	18	16	16	16	16	14

NCA08FA – NCA10FA - DU25HFA, DU30HFA, DU33HFA, DU50HFA - Curb 19 1/2" - Transition Plates DW1912TP & DW1914TP							
	Velocity						
CFM	1200	1300	1400	1500	1600	1700	1800
700	12	10	10	10	10	10	10
800	12	12	12	10	10	10	10
900	12	12	12	12	12	10	10
1000	14	12	12	12	12	12	12
1100	14	14	14	12	12	12	12
1200	14	14	14	14	12	12	12
1300	16	14	14	14	14	12	12
1400	16	16	14	14	14	14	12
1500	16	16	16	14	14	14	14
1600	16	16	16	14	14	14	14
1700	18	16	16	16	14	14	14
1800	18	16	16	16	16	14	14
1900	18	18	16	16	16	16	14

NCA08FA – NCA10FA - DU25HFA, DU30HFA, DU33HFA, DU50HFA - Curb 19 1/2" - Transition Plates DW1912TP & DW1914TP							
	Velocity						
CFM	1200	1300	1400	1500	1600	1700	1800
700	12	10	10	10	10	10	10
800	12	12	12	10	10	10	10
900	12	12	12	12	12	10	10
1000	14	12	12	12	12	12	12
1100	14	14	14	12	12	12	12
1200	14	14	14	14	12	12	12
1300	16	14	14	14	14	12	12
1400	16	16	14	14	14	14	12
1500	16	16	16	14	14	14	14
1600	16	16	16	14	14	14	14
1700	18	16	16	16	14	14	14
1800	18	16	16	16	16	14	14
1900	18	18	16	16	16	16	14

Duct Diameter: Transition Plates

NCA14FA - NCA14HPFA - DU75HFA - DU85HFA - Curb 23" - Transition Plates DW2314TP, DW2316TP & DW2318TP							
	Velocity						
CFM	1200	1300	1400	1500	1600	1700	1800
1000	14	12	12	12	12	12	12
1100	14	14	14	12	12	12	12
1200	14	14	14	14	12	12	12
1300	16	14	14	14	14	12	12
1400	16	16	14	14	14	14	12
1500	16	16	16	14	14	14	14
1600	16	16	16	14	14	14	14
1700	18	16	16	16	14	14	14
1800	18	16	16	16	16	14	14
1900	18	18	16	16	16	16	14
2000	18	18	18	16	16	16	16
2100	18	18	18	18	16	16	16
2200	20	18	18	18	16	16	16
2300	20	20	18	18	18	16	16
2400	20	20	18	18	18	18	16
2500	20	20	20	18	18	18	16
2600	20	20	20	18	18	18	18
2700	24	20	20	20	18	18	18
2800	24	20	20	20	18	18	18
2900	24	24	20	20	20	18	18
3000	24	24	20	20	20	18	18
3100	24	24	24	20	20	20	18

NCA16FA - NCA16HPFA – NCA18FA – NCA18HPFA - Curb 26 1/2" - Transition Plates DW2616TP, DW2618TP & DW2620TP							
	Velocity						
CFM	1200	1300	1400	1500	1600	1700	1800
1300	16	14	14	14	14	12	12
1400	16	16	14	14	14	14	12
1500	16	16	16	14	14	14	14
1600	16	16	16	14	14	14	14
1700	18	16	16	16	14	14	14
1800	18	16	16	16	16	14	14
1900	18	18	16	16	16	16	14
2000	18	18	18	16	16	16	16
2100	18	18	18	18	16	16	16
2200	20	18	18	18	16	16	16
2300	20	20	18	18	18	16	16
2400	20	20	18	18	18	18	16
2500	20	20	20	18	18	18	16
2600	20	20	20	18	18	18	18
2700	24	20	20	20	18	18	18
2800	24	20	20	20	18	18	18
2900	24	24	20	20	20	18	18
3000	24	24	20	20	20	18	18
3100	24	24	24	20	20	20	18
3200	24	24	24	20	20	20	20
3300	24	24	24	24	20	20	20
3400	24	24	24	24	20	20	20
3500	24	24	24	24	24	20	20
3600	24	24	24	24	24	20	20
3700	24	24	24	24	24	20	20
3800	N/A	24	24	24	24	24	20
3900	N/A	24	24	24	24	24	20

Duct Diameter: Transition Plates

NCA24FA - NCA24HPFA - Curb 31 1/2" - Transition Plate DW3124TP							
CFM	Velocity						
	1200	1300	1400	1500	1600	1700	1800
2700	24	20	20	20	18	18	18
2800	24	20	20	20	18	18	18
2900	24	24	20	20	20	18	18
3000	24	24	20	20	20	18	18
3100	24	24	24	20	20	20	18
3200	24	24	24	20	20	20	20
3300	24	24	24	24	20	20	20
3400	24	24	24	24	20	20	20
3500	24	24	24	24	24	20	20
3600	24	24	24	24	24	20	20
3700	24	24	24	24	24	20	20
3800	N/A	24	24	24	24	24	20
3900	N/A	24	24	24	24	24	20
4000	N/A	24	24	24	24	24	24
4100	N/A	N/A	24	24	24	24	24
4200	N/A	N/A	24	24	24	24	24
4300	N/A	N/A	24	24	24	24	24
4400	N/A	N/A	N/A	24	24	24	24
4500	N/A	N/A	N/A	24	24	24	24
4600	N/A	N/A	N/A	24	24	24	24
4700	N/A	N/A	N/A	24	24	24	24
4800	N/A	N/A	N/A	N/A	24	24	24
4900	N/A	N/A	N/A	N/A	24	24	24
5000	N/A	N/A	N/A	N/A	24	24	24
5100	N/A	N/A	N/A	N/A	N/A	24	24
5200	N/A	N/A	N/A	N/A	N/A	24	24
5300	N/A	N/A	N/A	N/A	N/A	24	24
5400	N/A	N/A	N/A	N/A	N/A	N/A	24
5500	N/A	N/A	N/A	N/A	N/A	N/A	24
5600	N/A	N/A	N/A	N/A	N/A	N/A	24

NCA30FA - NCA30HPFA - Curb 38 1/2" - Transition Plate DW3824TP							
CFM	Velocity						
	1200	1300	1400	1500	1600	1700	1800
2700	24	20	20	20	18	18	18
2800	24	20	20	20	18	18	18
2900	24	24	20	20	20	18	18
3000	24	24	20	20	20	18	18
3100	24	24	24	20	20	20	18
3200	24	24	24	20	20	20	20
3300	24	24	24	24	20	20	20
3400	24	24	24	24	20	20	20
3500	24	24	24	24	24	20	20
3600	24	24	24	24	24	20	20
3700	24	24	24	24	24	20	20
3800	N/A	24	24	24	24	24	20
3900	N/A	24	24	24	24	24	20
4000	N/A	24	24	24	24	24	24
4100	N/A	N/A	24	24	24	24	24
4200	N/A	N/A	24	24	24	24	24
4300	N/A	N/A	24	24	24	24	24
4400	N/A	N/A	N/A	24	24	24	24
4500	N/A	N/A	N/A	24	24	24	24
4600	N/A	N/A	N/A	24	24	24	24
4700	N/A	N/A	N/A	24	24	24	24
4800	N/A	N/A	N/A	N/A	24	24	24
4900	N/A	N/A	N/A	N/A	24	24	24
5000	N/A	N/A	N/A	N/A	24	24	24
5100	N/A	N/A	N/A	N/A	N/A	24	24
5200	N/A	N/A	N/A	N/A	N/A	24	24
5300	N/A	N/A	N/A	N/A	N/A	24	24
5400	N/A	N/A	N/A	N/A	N/A	N/A	24
5500	N/A	N/A	N/A	N/A	N/A	N/A	24
5600	N/A	N/A	N/A	N/A	N/A	N/A	24

Duct Diameter: Transition Plates

HRE13 - Curb 20 1/2" - Transition Plate DW1914TP & DW1916TP							
	Velocity						
CFM	1200	1300	1400	1500	1600	1700	1800
1000	14	12	12	12	12	12	12
1100	14	14	14	12	12	12	12
1200	14	14	14	14	12	12	12
1300	16	14	14	14	14	12	12
1400	16	16	14	14	14	14	12
1500	16	16	16	14	14	14	14
1600	16	16	16	14	14	14	14
1700	18	16	16	16	14	14	14
1800	18	16	16	16	16	14	14
1900	18	18	16	16	16	16	14
2000	18	18	18	16	16	16	16
2100	18	18	18	18	16	16	16
2200	20	18	18	18	16	16	16
2300	20	20	18	18	18	16	16
2400	20	20	18	18	18	18	16
2500	20	20	20	18	18	18	16

HRE16 - Curb 24 1/2" - Transition Plate DW2318TP & DW2620TP							
	Velocity						
CFM	1200	1300	1400	1500	1600	1700	1800
1700	18	16	16	16	14	14	14
1800	18	16	16	16	16	14	14
1900	18	18	16	16	16	16	14
2000	18	18	18	16	16	16	16
2100	18	18	18	18	16	16	16
2200	20	18	18	18	16	16	16
2300	20	20	18	18	18	16	16
2400	20	20	18	18	18	18	16
2500	20	20	20	18	18	18	16
2600	20	20	20	18	18	18	18
2700	24	20	20	20	18	18	18
2800	24	20	20	20	18	18	18
2900	24	24	20	20	20	18	18
3000	24	24	20	20	20	18	18
3100	24	24	24	20	20	20	18
3200	24	24	24	20	20	20	20
3300	24	24	24	24	20	20	20
3400	24	24	24	24	20	20	20
3500	24	24	24	24	24	20	20
3600	24	24	24	24	24	20	20
3700	24	24	24	24	24	20	20
3800	N/A	24	24	24	24	24	20
3900	N/A	24	24	24	24	24	20

Duct Diameter: Transition Plates

HRE20 - Curb 28 1/2" - Transition Plate DW2620TP & DW3124TP							
	Velocity						
2200	20	18	18	18	16	16	16
2300	20	20	18	18	18	16	16
2400	20	20	18	18	18	18	16
2500	20	20	20	18	18	18	16
2600	20	20	20	18	18	18	18
2700	24	20	20	20	18	18	18
2800	24	20	20	20	18	18	18
2900	24	24	20	20	20	18	18
3000	24	24	20	20	20	18	18
3100	24	24	24	20	20	20	18
3200	24	24	24	20	20	20	20
3300	24	24	24	24	20	20	20
3400	24	24	24	24	20	20	20
3500	24	24	24	24	24	20	20
3600	24	24	24	24	24	20	20
3700	24	24	24	24	24	20	20
3800	N/A	24	24	24	24	24	20
3900	N/A	24	24	24	24	24	20
4000	N/A	24	24	24	24	24	24
4100	N/A	N/A	24	24	24	24	24
4200	N/A	N/A	24	24	24	24	24
4300	N/A	N/A	24	24	24	24	24
4400	N/A	N/A	N/A	24	24	24	24
4500	N/A	N/A	N/A	24	24	24	24
4600	N/A	N/A	N/A	24	24	24	24
4700	N/A	N/A	N/A	24	24	24	24
4800	N/A	N/A	N/A	N/A	24	24	24
4900	N/A	N/A	N/A	N/A	24	24	24
5000	N/A	N/A	N/A	N/A	24	24	24
5100	N/A	N/A	N/A	N/A	N/A	24	24
5200	N/A	N/A	N/A	N/A	N/A	24	24
5300	N/A	N/A	N/A	N/A	N/A	24	24
5400	N/A	N/A	N/A	N/A	N/A	N/A	24
5500	N/A	N/A	N/A	N/A	N/A	N/A	24
5600	N/A	N/A	N/A	N/A	N/A	N/A	24

HRE24 - Curb 32 1/2" - Transition Plate DW3124TP							
	Velocity						
CFM	1200	1300	1400	1500	1600	1700	1800
2700	24	20	20	20	18	18	18
2800	24	20	20	20	18	18	18
2900	24	24	20	20	20	18	18
3000	24	24	20	20	20	18	18
3100	24	24	24	20	20	20	18
3200	24	24	24	20	20	20	20
3300	24	24	24	24	20	20	20
3400	24	24	24	24	20	20	20
3500	24	24	24	24	24	20	20
3600	24	24	24	24	24	20	20
3700	24	24	24	24	24	20	20
3800	N/A	24	24	24	24	24	20
3900	N/A	24	24	24	24	24	20
4000	N/A	24	24	24	24	24	24
4100	N/A	N/A	24	24	24	24	24
4200	N/A	N/A	24	24	24	24	24
4300	N/A	N/A	24	24	24	24	24
4400	N/A	N/A	N/A	24	24	24	24
4500	N/A	N/A	N/A	24	24	24	24
4600	N/A	N/A	N/A	24	24	24	24
4700	N/A	N/A	N/A	24	24	24	24
4800	N/A	N/A	N/A	N/A	24	24	24
4900	N/A	N/A	N/A	N/A	24	24	24
5000	N/A	N/A	N/A	N/A	24	24	24
5100	N/A	N/A	N/A	N/A	N/A	24	24
5200	N/A	N/A	N/A	N/A	N/A	24	24
5300	N/A	N/A	N/A	N/A	N/A	24	24
5400	N/A	N/A	N/A	N/A	N/A	N/A	24
5500	N/A	N/A	N/A	N/A	N/A	N/A	24
5600	N/A	N/A	N/A	N/A	N/A	N/A	24

Grease Duct Field Sheet

Use Area to Sketch Rise, Run, and Estimated Design

Job Name:

Job Location:

A large grid area for sketching the grease duct design. The grid consists of 30 columns and 30 rows of small squares, providing a space for drawing the rise, run, and estimated design of the duct system.

Grease Duct Field Sheet

Use Area to Sketch Rise, Run, and Estimated Design

Job Name:

Job Location:

