

CORE Pre-Engineered Fire Protection System Installation, Operation, and Maintenance Manual

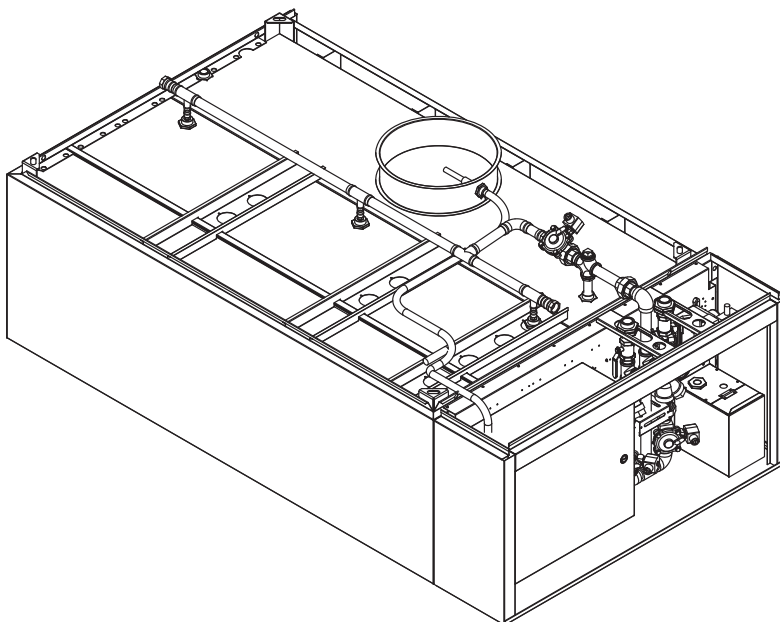

RECEIVING AND INSPECTION

Upon receiving unit, check for any interior and exterior damage. Report any damage found immediately to the carrier. Check that all accessory items are accounted for and free of damage.

WARNING!

Installation of this package should only be performed by a qualified Fire System Technician who has read and understands these instructions and is familiar with proper safety precautions. Improper installation poses serious risk of injury due to electric shock and other potential hazards. Read this manual thoroughly before installing or servicing this equipment. **ALWAYS** disconnect power prior to working on equipment.

**ONLY CORE CERTIFIED PERSONNEL MAY INSTALL,
PERFORM MAINTENANCE AND REPAIRS ON CORE SYSTEMS.**

Save these instructions: This document is the property of the owner of this equipment and is required for future maintenance. Leave this document with the owner when installation or service is complete.

Table of Contents

WARRANTY	3
LISTINGS	3
INSTALLATION	4
Mechanical	4
Self Cleaning System Options	4
CORE Total Flood Fire System Options	4
Plumbing Connections for CORE Total Flood Protection	6
Piping Loss Calculation for Wall Mount CORE Total Flood Protection Fire Systems	7
Self Cleaning Tees and Duct Sump(s) Coverage	12
CORE Hood Details	12
Drain Assembly Piping	13
Gas Shut-Off Valves	14
Electrical	16
Wire Ampacity Rating	17
Distance Limitations	17
Fire Alarm Contacts	17
Fire Group	18
CORE Duct and Plenum Coverage	19
CORE Total Flood Coverage	19
Hazard Zone and Nozzle Placement	19
Appliance Coverage	20
Standard Overlapping Protection	21
Appliance Spray Bar	22
Upright Broiler Protection	23
Range Top Protection	24
Wok Protection	25
Large Wok Protection	26
Salamander Protection	27
Large Appliance Protection	28
Large Industrial Fryer Protection	29
OPERATION	30
Self Cleaning Hood	30
Self Cleaning System Overview	30
Self Cleaning Hood Start-up	32
Start-Up Procedure – Self Cleaning Hood	32
Filter Installation Configuration	33
CORE Protection Fire System	34
CORE Protection Test Mode Overview	34
CORE Protection Reset Overview	34
Start-up Procedure – CORE Protection Fire System	35
Start-up Procedure – Firestat Activation	35
Start-Up Procedure – Remote Manual Actuation Device Activation	36
Start-up Procedure – Battery Back-Up	36
Start-Up Procedure – Final	37
Reset Procedure – CORE Protection Fire System	37
CORE Total Flood Fire System Overview	38
CORE Total Flood Protection Fire System Start-Up	39
Jobsite Qualifications – Pre-installation CORE Protection Fire System	39
Start-up Checklists	40
Component Description	41
Self Cleaning Spray Bar/CORE Duct and Plenum Coverage	41
Water Manifolds	42
3/4" Self Cleaning with CORE Total Flood Protection Manifold	43
1" Self Cleaning with CORE Total Flood Protection Manifold	44
1-1/2" Self Cleaning with CORE Total Flood Protection Manifold	45
3/4" Self Cleaning with CORE Wall Mounted Utility Cabinet Manifold	46
1" Self Cleaning with CORE Wall Mounted Utility Cabinet Manifold	47
1-1/2" Self Cleaning with CORE Wall Mounted Utility Cabinet Manifold	48
3/4" Duct & Plenum Protection Manifold	49
1" CORE Duct and Plenum Protection Manifold	50
1-1/2" CORE Duct and Plenum Protection Manifold	51
Wall Mounted Self Cleaning and CORE Manifold	52
Wall Mount CORE Manifold with Monitored Ball Valve	53
Fire Protection System Printed Circuit Board	54
Connector Descriptions	55
DIP Switch Settings	57
Typical DIP Switch Arrangement	58
Fire Protection System Supervised Loops	59
Supervised Loop Electrical Details	60
Fire Protection Manual Actuation Device	61
Fire Protection System Firestat	62
Non-Solid Fuel Appliances (Rated 450°F)	62
Non-Solid Fuel Appliances (Rated 600°F)	62
Solid Fuel Appliances (Rated 700°F)	62
Hood Riser Sensor Replacement	64
Surfactant Tank	65
CORE Protection Waterline Supervision	66
Battery Backup	67
Power Supply Adjustment	67
Heat Recovery Coil (Optional)	68
TROUBLESHOOTING	70
CORE Board Faults	71
Appliance Shutdown in Fault Conditions	72
Local Alarm Muting	72
Test Mode	72
Self Cleaning Hood Troubleshooting	73
Supervised Loop/Power Supply Troubleshooting	74
MAINTENANCE	75
General Maintenance	75
Every 6 months	75
Every 2 Years	75
Decommissioning	75
After A Fire	75
Start-up and Maintenance Documentation	78
Job Information	78
CORE System Verification	78

WARRANTY

This equipment is warranted to be free from defects in materials and workmanship, under normal use and service, for a period of 5-years from date of shipment. Warranty does not cover consumable products such as batteries, surfactant, and nozzle caps. This warranty shall not apply if:

1. The equipment is not installed by a certified CORE installer per the MANUFACTURER'S installation guide; the operation manual should be kept with the equipment after installation is complete.
2. The equipment is not installed in accordance with Federal, State, and Local codes and regulations.
3. The equipment is misused or neglected, or not maintained per the MANUFACTURER'S maintenance instructions.
4. The equipment design or sizing is not approved per MANUFACTURER'S specifications.
5. The equipment is exposed to elevated temperatures due to a fire originating in the building, hood, fan, vent, or kitchen appliances.
6. The equipment is not installed and operated within the limitations set forth in this manual.
7. The invoice is not paid within the terms of the sales agreement.

The MANUFACTURER shall not be liable for incidental and consequential losses and damages potentially attributable to malfunctioning equipment. Should any part of the equipment prove to be defective in material or workmanship within the 5-year warranty period, upon examination by the MANUFACTURER, such part will be repaired or replaced by MANUFACTURER at no charge. The BUYER shall pay all labor costs incurred in connection with such repair or replacement. Equipment shall not be returned without MANUFACTURER'S prior authorization, and all returned equipment shall be shipped by the BUYER, freight prepaid to a destination determined by the MANUFACTURER.

NOTE: To receive warranty coverage for this product, copy and print out the "Start-up and Maintenance Documentation" on page 78. Fill in all details required. Fax the page to 1-919-516-8710 or call 1-866-784-6900 for email information within thirty (30) days of purchase.

LISTINGS

The CORE Fire Protection System is a Pre-Engineered system that is ETL Listed to UL Standard 300 and ULC/ORD-C1254.6-1995; meets requirements of NFPA 96 (Standard for the Installation of Equipment for the Removal of Smoke and Grease-Laden Vapors from Commercial Cooking Equipment); NFPA 17A (Standard on Wet Chemical Extinguishing Systems).

The CORE Fire Protection System is acceptable for use in New York City and approved per FDNY COA #5877.

Patents

The CORE Pre-Engineered Fire Protection System is a Patented Product, Patent No. 7963282 and 8378834.

INSTALLATION

Refer to project blueprints for proper plumbing and electrical connections. It is imperative that this unit is installed and operated within the designed specifications and electrical supply in accordance with this manual. If there are any questions about any items, please call the service department at **1-866-784-6900** for warranty and technical support issues.

CAUTION: Do not apply power before plumbing and electrical installation is complete on the panel.

Mechanical

WARNING: APPLY THE APPROPRIATE WATER PRESSURE AND TEMPERATURE TO ALL FITTINGS TO PREVENT LEAKAGE AND COMPONENT FAILURE. SYSTEM MUST BE INSTALLED IN CONDITIONED SPACE BETWEEN 32°F AND 130°F.

Ensure there is 36 inches of service clearance to the front of the panel. The panel must be located in an accessible area where the audible and visual alarms can be heard and seen.

IMPORTANT!

CORE Protection water connection requires a supervised supply line. This must be connected immediately downstream from the building main shut-off valve or building sprinkler system. The main shut-off valve must be supervised.

Self Cleaning System Options

In self cleaning mode, the hot water solenoid opens, allowing hot water to flow to the duct and plenum of the hood. Surfactant is injected at a rate of one second per minute of wash. The diagram below shows the Hot Water side of the utility cabinet mounted manifold that is activated during the “wash” cycle. The CORE sprinkler water solenoid remains closed during the wash cycle.

The appliance solenoid remains closed on top of the hood preventing hot water from spraying on the appliances. Hot Water only flows to the duct and plenum area during the self cleaning cycle.

The hot water fully integrated self cleaning system uses the basic manifold with the addition of a detergent pump and timers to control the system. When the fan power switch is turned off, the system sprays and injects surfactant into the plenum for cleaning. The length of the wash cycle and surfactant injection are adjustable. It is recommended that the wash time is set to 3 minutes, and detergent injection is 1 second every minute.

Operating water pressure for the self cleaning function is dependent on the total equivalent length of hood, and generally fall between 30 to 70 psi. The maximum static pressure is 125 psi. Hot water temperatures must be between 140°F to 170°F.

CORE Total Flood Fire System Options

In a fire condition, the CORE water solenoid is open, allowing sprinkler water to flow through the manifold. The surfactant is injected continuously throughout the fire system activation. **Figure 2 on page 5** shows the Sprinkler Water side of the utility cabinet mounted manifold that is activated during a “fire” condition. The hot water solenoid remains closed during a fire condition. The appliance solenoid on top of the hood opens, allowing water to flow to the duct, plenum, and appliance spray bar.

Primary water sprinkler fire protection for commercial kitchen hoods. Duct, plenum, and appliance fire system protection is provided by this option per UL300. Appliance protection provided by total flood protection. Duct mounted sensor electronically activates the water spray system to extinguish duct, plenum, and appliance fires.

Operating water pressure varies depending on hood length, and generally falls between 30-70 psi when water is spraying. Max water static pressure is 125 psi.

IMPORTANT!

Filters must be installed for proper system operation. Filters can be removed once the system is off.

Figure 1 - Self Cleaning with CORE Protection Fire System

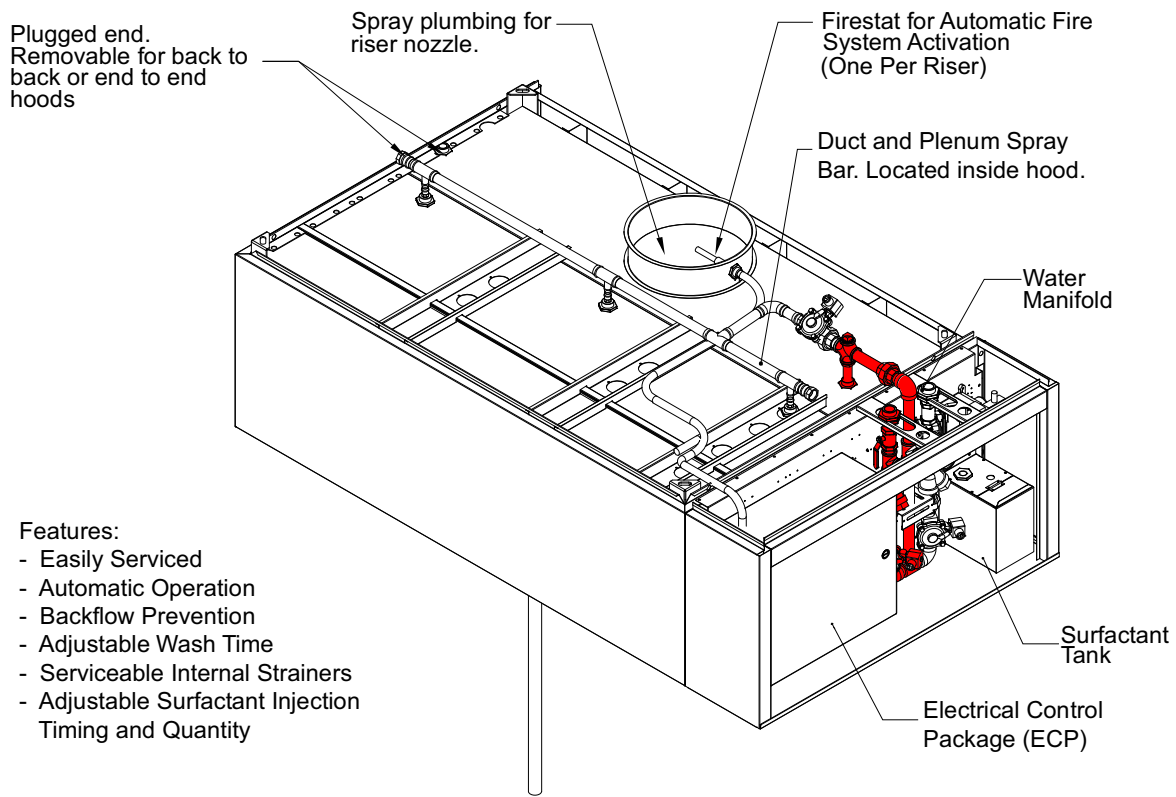
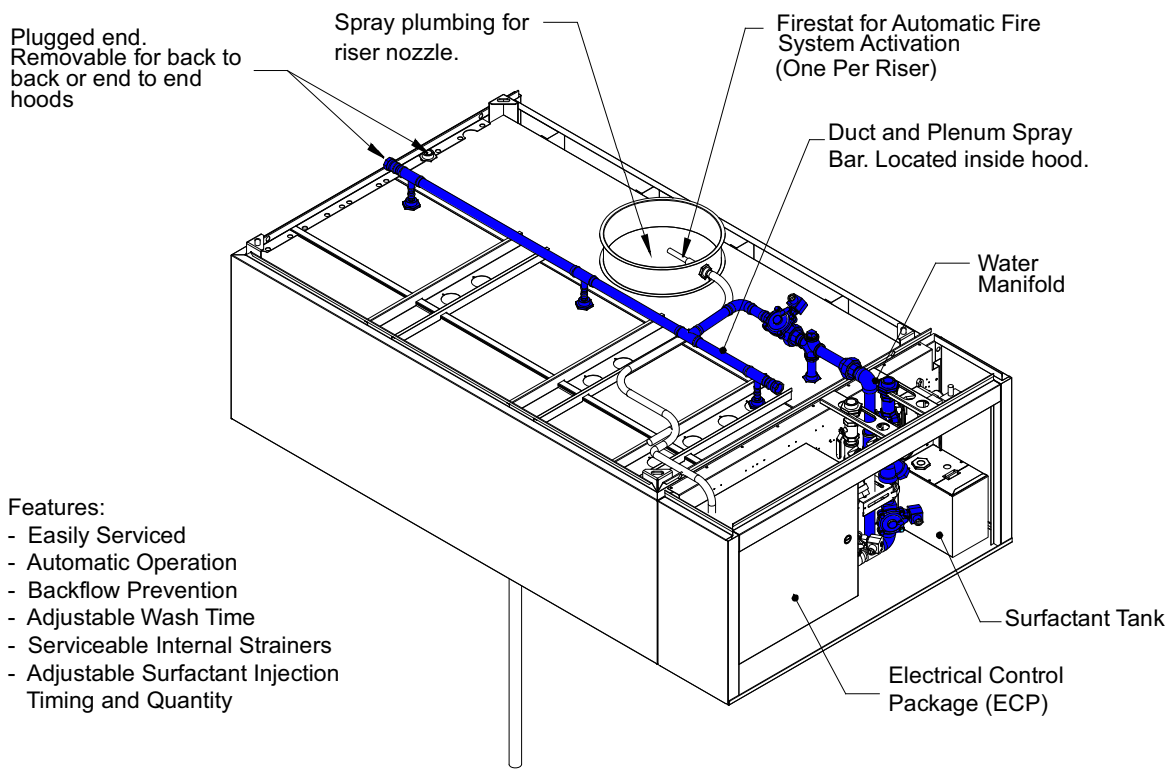

Figure 2 - CORE Total Flood Fire System



Plumbing Connections for CORE Total Flood Protection

Several field plumbing connections are required for proper self cleaning with CORE Total Flood Protection fire system hood operation. It is recommended that all plumbing connections be sealed with Teflon tape or pipe dope. Use care not to contaminate the interior surfaces of the water lines when plumbing the unit, as small particulates can clog the orifices of the spray nozzles.

1. All incoming plumbing connections are connected to the top of the CORE manifold via quick-seals, or bell reducing couplings if the incoming pipe diameter is larger than the CORE manifold pipe diameter. The hot water line can be PVC, copper, stainless steel pipe, or listed braided hose only. If PVC is utilized, there must be a minimum of **10 ft** of copper or stainless steel pipe from the manifold to the PVC connection. The CORE water line must be copper, stainless steel, steel pipe, or listed braided hose only. Refer to **Figure 1 on page 5** and **Figure 4 on page 12** for details.
2. Self Cleaning hoods with the **WC** option (Hot Water Wash) require a hot water connection at 140°F to 170°F, and a minimum required PSI to 70 PSI operating pressure, per **Table 3 on page 9** through **Table 7 on page 11**. If the operating pressure is greater than 70 PSI, a water regulator must be connected. Max water static pressure is 125 PSI. Typical water flow rate is 0.7 GPM per foot of hood. The spray lasts for a factory setting of 3 minutes every time the fans are switched off.
3. A pressure supervision switch must be connected to the CORE inlet water supply line. Refer to **“CORE Protection Waterline Supervision” on page 66**. This requires an unheated water connection per the minimum required PSI to 70 PSI operating pressure. Water pressure may not drop below the minimum recommended PSI while the hood is spraying. Pressure may not rise above 70 PSI when the hood is spraying. If the operating pressure is greater than 70 PSI, a water regulator must be connected. Max water static pressure is 125 PSI. Typical water flow rate is 1.5 GPM per foot of hood.
4. The water connection must be minimum 3/4” pipe. This must be connected to a water supply line immediately downstream from the building main shut-off valve or a fire sprinkler system. This main valve must be continuously supervised. If the CORE water supply is connected to the building sprinkler system, it is preferred that the connection is from the main sprinkler riser, or a branch line as long as the CORE system is calculated in the overall sprinkler system capacity. For domestic water supply, if other appliances are connected to the CORE water supply line, those appliances must be operated during CORE system testing and taken into consideration when calculating the size of the water pipe. Refer to **Table 3** through **Table 7** for hood length and pressure requirements.
5. If multiple hoods are arranged in an end-to-end or back-to-back arrangement, plumbing connecting the hoods must be piped in the field. The plugged end of the Appliance and Plenum spray bars is used to do this. Remove the plugs on the main hood and the adjacent hood and simply pipe the Appliance spray bars together and Plenum spray bars together. It is important not to cross-connect the spray bars.
6. If a remote mounted manifold is used with CORE Total Flood Protection, the appliance solenoid will be installed at the plant.
7. There is also a non-pressurized 1-1/2 inch drain connection that must be piped. This allows water to drain from the hood grease trough. It must be connected to the building grease trap. Hoods 10’ in length (or greater) will require 2 drains. 24” tall hoods with 20” filters will require 2 drains. All other hoods will require 1 drain. Refer to **Figure 5 on page 13** for details.
8. If a remote mounted manifold with backflow preventer is used, the backflow preventer drain must be piped according to the manufacturer’s instructions.
9. Once all supply and drain lines are connected, remove one of the nozzles and flush the lines.

Warning!

All field connections between hoods, and incoming CORE Protection lines must be run with Copper, Stainless Steel, Steel Pipe, or Listed Braided Hose. Both dynamic and static pressure must be verified. Drain lines must be run with Brass, Stainless Steel, or Copper Pipe. Plastic pipe cannot be used for drains, field connections between hoods, or CORE Protection supply lines as it could fail and become hazardous.

Piping Loss Calculation for Wall Mount CORE Total Flood Protection Fire Systems

The correct water pressure must be achieved at the hood inlet, refer to **Table 3 on page 9** through **Table 7 on page 11** for operating pressures. To ensure proper operation of the CORE Protective Fire System, proper sizing of the water line is required. Use the following steps to calculate the minimum piping size.

1. Refer to **Table 3** through **Table 7** to determine the CORE minimum PSI required at the hood inlet. Subtract this value from the available psi at the panel pressure gauge. Maximum panel operating pressure is 70 psi. This will be your maximum allowable pressure drop for field-installed piping between the panel and the hood.
2. Most fittings add an equivalent pipe length to the total run. Use **Table 1 on page 8** to calculate the equivalent pipe length for installed fittings. If you have multiple fittings of one type, simply multiply the number by the total number of the fitting and add to the total run length.
3. To calculate the total flowing pressure drop between the panel and the hood, take the total equivalent length found in step 2 and add the total linear field-installed pipe length. Multiply this number by the value found in **Table 2 on page 9**. Gallons per minute is calculated by multiplying the length of the hood by 1.5 GPM, this will be the friction pressure drop between the hood and the panel.
4. Add in the pressure drop due to gravity. This must be evaluated to overcome any rise in pipe elevation between the panel and the hood. There is 0.43 psi /ft of vertical rise of pressure drop.
5. Compare the maximum allowable pressure drop from step 1 to the calculated pressure drop from step 3. If the calculated pressure drop exceeds the maximum allowable pressure drop, increase the pipe size, and recalculate steps 2 and 3. Continue this step until the calculated pressure drop is below the maximum allowed specification.

Field Pipe Pressure Drop Calculation Example:

Wall mount panel installed with 30 feet of 3/4" linear pipe between panel and hood. If four (4) 90-degree elbows are installed in the pipe run, and the pipe run has a vertical rise of 5 feet, the hood length of end-to-end system is 32 feet.

Hood System = 32 feet. Flow rate = 32 feet * 1.5 gpm = 48 gpm

Pressure required at hood = 44 psi.

Pressure at panel gauge = 50 psi.

Allowable pressure drop between panel and hoods: 50 psi – 44 psi = **6 psi**

Equivalent length of pipe = 30 + 4 * 2.10 = 38.40 feet

Friction Pressure Drop through pipe = 38.40 * 2.005 = 76.99 psi

Gravitational Pressure = 0.43 psi/ft * 5 feet = 2.15 psi

Total Pressure Drop in Field Pipe between panel and hood = 76.99 psi + 2.15 psi = **79.14 psi**

Allowable pressure drop = **6 psi**

This system will not work correctly because calculated pressure drop is greater than allowable pressure drop. Pipe size will need to be change to 1-1/2 inch diameter.

Re-calculate with 1-1/2 inch pipe instead of 3/4" pipe:

Equivalent length of pipe = 30 + 4 * 4.00 = 46 feet

Friction Pressure Drop through pipe = 46 * 0.078 = 3.58 psi

Gravitational Pressure = 0.43 psi/ft * 5 feet = 2.15 psi

Total Pressure Drop in Field Pipe between panel and hood = 3.58 psi + 2.15 psi = **5.74 psi**

Allowable pressure drop = **6 psi**

This system will work correctly because calculated pressure drop is less than allowable pressure drop.

Table 1 - Equivalent Pipe Length for Various Pipe Fittings

Pipe Size Inches	45° Elbow	90° Elbow	Tee Thru Run	Tee Thru Branch
3/4"	0.97	2.10	1.40	4.10
1"	1.23	2.60	1.80	5.30
1-1/2"	1.90	4.00	2.70	8.00
2"	2.40	5.20	3.50	10.40

Figure 3 - Pressure Loss through Typical Water Pipe Chart

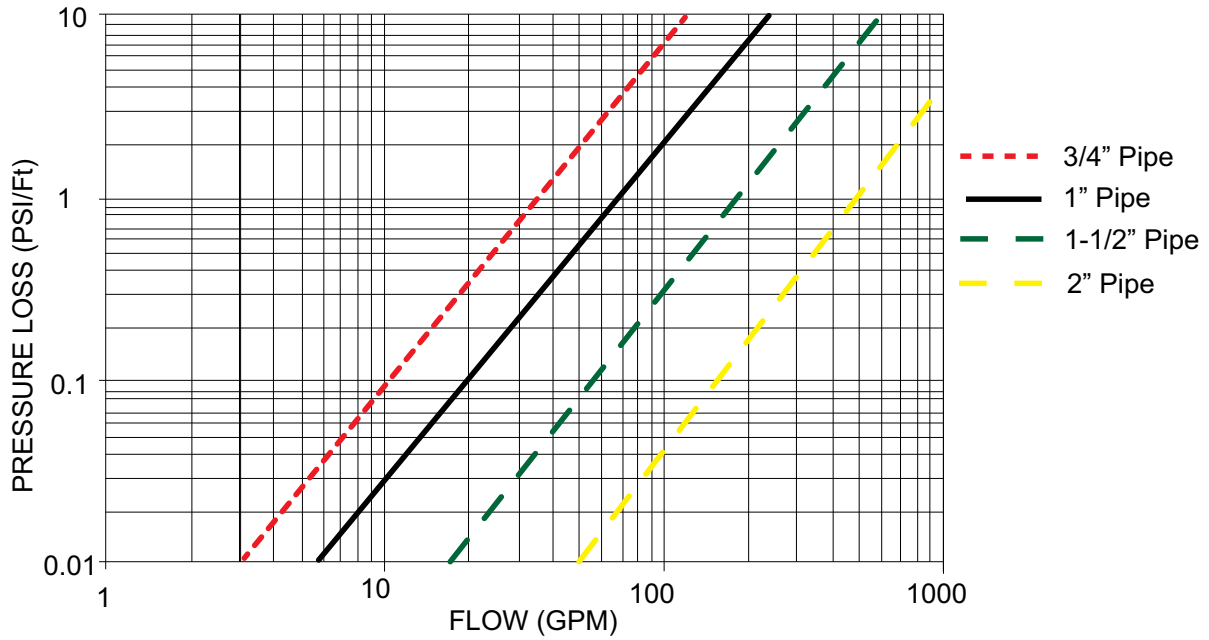

Table 2 - Pressure Drop (PSI) per Equivalent Foot of Waterline (Pipe Size)

Gallons per Minute	Waterline Pipe Size (PSI per foot of pipe)			
	3/4"	1"	1-1/2"	2"
5	0.028	0.008	0.001	0.000
10	0.102	0.029	0.004	0.001
15	0.216	0.062	0.008	0.001
20	0.368	0.105	0.014	0.002
25	0.556	0.159	0.022	0.003
30	0.779	0.223	0.030	0.004
35	1.036	0.296	0.040	0.006
40	1.327	0.379	0.052	0.008
45	1.650	0.472	0.064	0.009
50	2.005	0.573	0.078	0.011
55	2.391	0.684	0.093	0.014
60	2.809	0.803	0.110	0.016
65	3.257	0.931	0.127	0.019
70	3.736	1.068	0.146	0.021
75	4.244	1.213	0.166	0.024
80	4.782	1.367	0.187	0.027
85	5.350	1.529	0.209	0.030
90	5.946	1.700	0.232	0.034
95	6.572	1.879	0.256	0.037
100	7.226	2.066	0.282	0.041
105	7.909	2.261	0.309	0.045

Table 3 - 3/4" Manifold Minimum Operating Pressure Requirements for Hood Lengths

Hood Length (FT)	Minimum Inlet Water Pressure for Self Cleaning (PSI)	Minimum Inlet Water Pressure for Duct & Plenum Protection Only (PSI)	Duct and Plenum Discharge Coefficients (K Factor)	Minimum Inlet Water Pressure for CORE Total Flood Protection (PSI)	Total Flood Discharge Coefficients (K Factor)
4	30	30	0.6	30	1.3
8	30	30	1.3	30	2.7
12	30	30	1.9	30	4.0
16	30	30	2.5	30	5.4
20	31	31	3.1	33	6.4
24	32	32	3.7	36	7.4
28	34	34	4.2	39	8.4
32	37	37	4.6	44	9.1
36	39	39	5.0	49	9.7
40	42	42	5.4	56	10.2
44	46	46	5.7	63	10.7
48	50	50	6.0	70	11.1

Table 4 - 1" Manifold Minimum Operating Pressure Requirements for Hood Lengths

Hood Length (FT)	Minimum Inlet Water Pressure for Self Cleaning (PSI)	Minimum Inlet Water Pressure for Duct & Plenum Protection Only (PSI)	Duct and Plenum Discharge Coefficients (K Factor)	Minimum Inlet Water Pressure for CORE Total Flood Protection (PSI)	Total Flood Discharge Coefficients (K Factor)
4	30	30	0.6	30	1.3
8	30	30	1.3	30	2.7
12	30	30	1.9	30	4.0
16	30	30	2.5	30	5.4
20	30	30	3.1	30	6.7
24	30	30	3.8	30	8.1
28	31	31	4.3	33	9.0
32	33	33	4.8	35	10.0
36	35	35	5.3	45	10.1
40	42	42	5.4	50	10.7
44	43	43	5.9	55	11.3
48	45	45	6.3	60	11.9

Table 5 - 1-1/2" Manifold Minimum Operating Pressure Requirements for Hood Lengths

Hood Length (FT)	Minimum Inlet Water Pressure for Self Cleaning (PSI)	Minimum Inlet Water Pressure for Duct & Plenum Protection Only (PSI)	Duct and Plenum Discharge Coefficients (K Factor)	Minimum Inlet Water Pressure for CORE Total Flood Protection (PSI)	Total Flood Discharge Coefficients (K Factor)
4	30	30	0.6	30	1.3
8	30	30	1.3	30	2.7
12	30	30	1.9	30	4.0
16	30	30	2.5	30	5.4
20	30	30	3.1	30	6.7
24	30	30	3.8	30	8.1
28	30	30	4.4	30	9.4
32	30	30	5.0	30	10.7
36	33	33	5.4	35	11.3
40	35	35	5.9	40	11.8
44	38	38	6.2	45	12.4
48	40	40	6.6	50	12.9

Table 6 - 1" Manifold Minimum Operating Pressure Requirements for Hood with Self Cleaning Filters

Hood Lengths (FT)	Minimum Inlet Water Pressure for Self Cleaning (PSI)	Minimum Inlet Water Pressure for Duct & Plenum Protection Only (PSI)	Duct and Plenum Discharge Coefficients (K Factor)	Minimum Inlet Water Pressure for CORE Total Flood Protection (PSI)	Total Flood Discharge Coefficients (K Factor)	Water Heater Instantaneous Demand (MBH)
4	30	30	1.3	30	2.7	250
8	30	30	2.5	30	5.4	500
12	30	30	3.8	30	8.1	725
16	33	33	4.8	35	10.0	975
20	42	42	5.4	50	10.7	1200
24	45	45	6.3	60	11.9	1450

Table 7 - 1-1/2" Manifold Minimum Operating Pressure Requirements for Hood with Self Cleaning Filters

Hood Lengths (FT)	Minimum Inlet Water Pressure for Self Cleaning (PSI)	Minimum Inlet Water Pressure for Duct & Plenum Protection Only (PSI)	Duct and Plenum Discharge Coefficients (K Factor)	Minimum Inlet Water Pressure for CORE Total Flood Protection (PSI)	Total Flood Discharge Coefficients (K Factor)	Water Heater Instantaneous Demand (MBH)
4	30	30	1.3	30	2.7	250
8	30	30	2.5	30	5.4	500
12	30	30	3.8	30	8.1	725
16	33	33	5.0	30	10.7	975
20	35	35	5.9	40	11.8	1200
24	40	40	6.6	50	12.9	1450

NOTE: Water pressure may not drop below the minimum required psi while the hood is spraying hot water or for CORE. Pressure may not rise above 70 psi when the hood is spraying. If the operating pressure is greater than 70 psi, a water regulator must be connected.

Table 3 through Table 7 are for continuous back to back and/or end to end hood installations. If the pipe connecting any hood contains excessive elbows or complicated paths, additional pressure may be required to overcome this pressure loss. Contact engineering for clarification in these circumstances.

When additional nozzles are added to a CORE system, beyond the standard overlapping coverage, each nozzle is equal to 1 gpm. Each nozzle is equivalent to adding 8 additional inches of hood. To find the new pressure requirements, add the additional length to the base hood length, then refer to Table 3 through Table 7 based on the new equivalent hood length.

Example: When three (3) additional nozzles are added to a CORE system, the total consumption is increased by 3 gpm. The minimum pressure requirements can be found in Table 3 through Table 7, by adding 24 inches to the base hood length.

To determine the minimum pressure requirements when CORE Total Flood Protection is mixed with CORE Duct & Plenum Coverage, it is necessary to recalculate the system total hood length. The equivalent hood length of Duct & Plenum coverage is equal to 8 inches per 1 foot.

Example: If you have a 10'-0" Hood with CORE Total Flood protection and a 12'-0" Hood with CORE Duct & Plenum coverage, the total equivalent hood length is 10'-0" + (12'-0" * 0.75) = 19'-0".

The discharge coefficient, or "K Factor", is used to calculate the actual GPM through the system when the incoming pressure is above the minimum stated Table 3 through Table 7. This K factor can be applied to the completed hood assembly. The formula below will provide the Gallons per Minute discharge rate of the hood fire system.

$$\text{Total Flow Rate} = \text{K Factor} \times \text{Pressure}^{0.44}$$

Self Cleaning Tees and Duct Sump(s) Coverage

CORE Fire Protection System manifolds can also cover Duct Sumps and Self Cleaning tees within the duct run. These duct assemblies will be added to the total GPM required and added to the total equivalent hood length for pressure requirements. If duct is covered by a hood mounted CORE Fire Protection System, refer to **Detail A** in **Figure 4** for supply connection location. Duct runs with multiple self cleaning tees and/or duct sumps can be divided into zones. Each zone can be covered by a separate CORE manifold.

Round and rectangular Duct Sumps and Self Cleaning Tees require a minimum of 30 psi at the inlet of the tee. They have a 3/4" water inlet connection (and 1-1/2" drain size, if applicable) and require 140-170°F water temperature.

Water Requirements: Each Self Cleaning tee nozzle adds 2.6 GPM to the total flow rate. Each Self Cleaning tee can contain Qty (1) or Qty (2) Self Cleaning nozzles.

Each Duct Sump (round) adds 3.5 GPM to the total flow rate. Each Duct Sump has Qty (5) nozzles, each nozzle at 0.7 GPM for a total of 3.5 GPM.

Each duct run covered by a CORE Fire Protection manifold will add the total GPM of the duct run to the system requirements. The total GPM of the duct run is divided by a factor of 1.5 (for CORE) or 0.7 (for Self Cleaning) to calculate the additional equivalent hood length to add to the system.

Equations for Duct Coverage: Additional CORE Equivalent Hood Length = Total Duct GPM / 1.5
 Additional Self Cleaning Equivalent Hood Length = Total Duct GPM / 0.7

Example: An 8 ft long hood covered by CORE Fire Protection, which also covers a duct run with Qty (1) Duct Sump with a 2-nozzle Self Cleaning tee.

CORE Flow Rate = $(1.5 \text{ GPM/ft} * 8 \text{ ft}) + (2.6 \text{ GPM} * 2) + (3.5 \text{ GPM} * 1) = 20.7 \text{ GPM}$

Self Cleaning Flow Rate = $(0.7 \text{ GPM/ft} * 8 \text{ ft}) + (2.6 \text{ GPM} * 2) + (3.5 \text{ GPM} * 1) = 14.3 \text{ GPM}$

CORE Equivalent Hood Length = $8 \text{ ft} + (2.6 \text{ GPM} * 2 + 3.5 \text{ GPM} * 1) / 1.5 \text{ GPM/ft} = 13.8 \text{ ft}$

Self Cleaning Equivalent Hood Length = $8 \text{ ft} + (2.6 \text{ GPM} * 2 + 3.5 \text{ GPM} * 1) / 0.7 \text{ GPM/ft} = 20.4 \text{ ft}$

CORE Hood Details

Figure 4 - CORE Hood Top and Bottom View

Important: All wiring between fire sensor and electrical control package that is on top of the hood must use high temperature wire (842°F/450°C).

Wire type MG or MGT, 16 gauge minimum.

Notes:

1. Plenum of hood must be dye penetrate tested for leaks.
2. Instead of 1" OD grease drain, hood must have 1-1/2" NPT drains installed. Follow same rules as the standard grease drains. This is dye penetrated tested.
3. Hood lengths over 10-feet must have center supports. This support consists of a 3/4" tee close pipe nipple, and a quick seal with a cap spaced evenly throughout the spray bar.

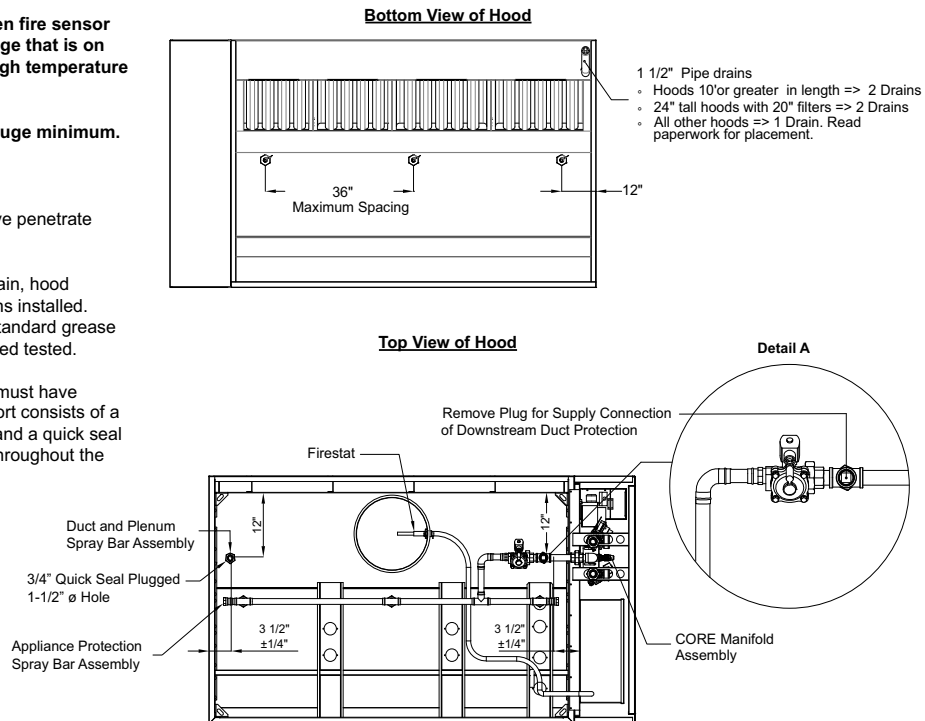

Drain Assembly Piping

Figure 5 - Drain Assembly

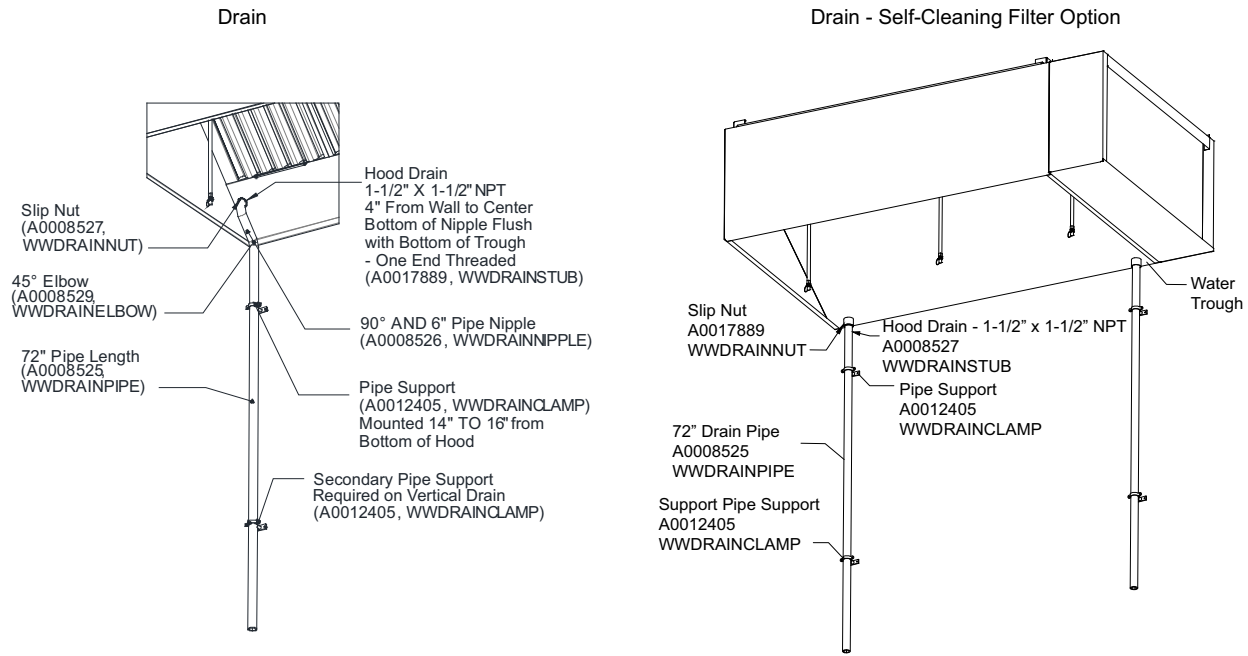

Wipe down water trough daily. Check and clean filters periodically.

Replace filters per required maintenance recommendations.

Not all drain components provided in the drain kit are used on hoods with self cleaning filters.

NOTE: Filters must be removed from the hood every 3 months. Inspect and clean filters per recommendations in the Hood Installation, Operation, and Maintenance Manual.

Gas Shut-Off Valves

Gas valves (**Figure 6**) are designed to shut off the flow of gas to the kitchen appliances in the event of fire system activation. Electric gas shutoff valves must be installed with an upstream strainer to prevent debris from prohibiting gas valve function. New pipe, properly reamed and cleaned of metal burrs, should be used. Proper care is needed to ensure that the gas flow is in the same direction as indicated on the gas valve and strainer. Do not over-tighten pipe connections. Apply pipe dope to the male threads only. If necessary, install a drip leg in the gas line in accordance with the Authority Having Jurisdiction (AHJ).

120V AC gas valves 3/4" - 2" can be mounted with the solenoid in any position above horizontal.

120V AC gas valves 2-1/2" - 3" must be mounted with the solenoid vertical and upright. The pipe must be horizontal.

All **24V DC** gas valves must be mounted with the solenoid vertical and upright. The pipe must be horizontal.

Proper clearance must be provided in order to service the strainers. A minimum of 4" clearance distance must be provided at the base of the strainer.

Figure 6 - Electric Gas Valve

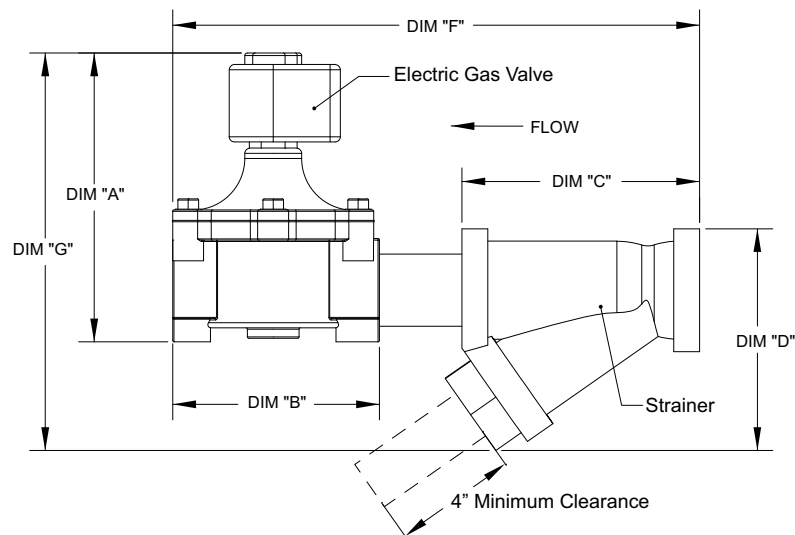

Table 8 - Gas Valve Details

Gas Valve ASCO	Size	DIM "A"	DIM "B"	DIM "C"	DIM "D"	DIM "E"	DIM "F"	DIM "G"
8214235	3/4"	6-15/16"	5-15/16"	4"	4-1/2"	11-15/16"	9-7/8"	
8214250	1"	6-15/16"	5-15/16"	4-7/8"	5-3/16"	12-13/16"	10-11/16"	
8214265	1-1/4"	7-5/8"	6-3/8"	5-1/8"	5-15/16"	13-1/2"	12-1/16"	
8214275	1-1/2"	7-5/8"	6-3/8"	5-3/4"	6-3/16"	14-1/8"	12-5/16"	
8214280	2"	7-5/8"	6-3/8"	7-1/4"	7-13/16"	15-5/8"	13-15/16"	
8214290	2-1/2"	10-5/16"	8-1/16"	8-7/8"	9-7/8"	18-15/16"	18-5/8"	
8214240	3"	10-5/16"	8-1/16"	10"	10-15/16"	20-1/16"	19-11/16"	

A gas strainer is supplied with the unit and recommended to be installed.

Wall-Mount Utility Cabinet Installation (Optional)

The utility cabinet must be secured to the wall using a minimum of eight fasteners and washers. Use four fasteners/washers on the top of the cabinet, and four fasteners/washers on the bottom, refer to **Figure 7**.

1. Mark locations in the top and bottom angle-iron of the utility cabinet.
2. Drill pilot holes for fasteners.
3. When installing to the wall:
 - Concrete/Masonry - use 5/16"x2-1/4" Tapcons.
 - Metal Studs - use 5/16"x1-1/2" Self Drilling Screws.
 - Wooden Studs - use 5/16"x3-1/2" Lag Bolts.
 - Drywall (only) - use 5/16"x4" Long Toggle Bolts.

NOTE: Wall-mounted utility cabinets up to 48" long, must be secured to 2 studs minimum (top and bottom of the utility cabinet). Wall-mounted utility cabinets over 48" long, must be secured to 3 studs minimum (top and bottom of the utility cabinet).

Figure 7 - Wall-Mount Utility Cabinet Details

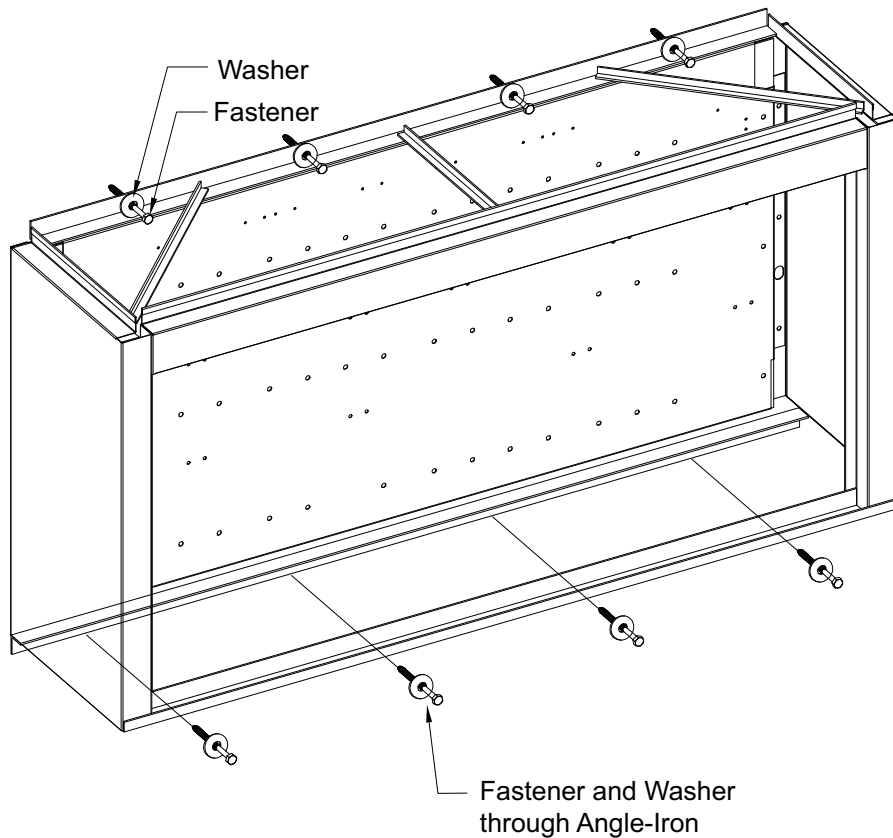

Electrical

WARNING!

Disconnect power before installing or servicing control. High voltage electrical input is needed for this equipment. A qualified electrician should perform this work.

Before connecting power to the control package, read and understand the entire section of this document. As-built wiring diagrams are furnished with each control package from the factory and are either attached to the door of the unit or provided with the paperwork packet.

Electrical wiring and connections must be made in accordance with local ordinances and the National Electric Code, ANSI/NFPA70. Verify the voltage and phase of the power supply, and the wire amperage capacity is in accordance with the unit's nameplate.

ATTENTION: LOW-VOLTAGE DC OR SIGNALING WIRE SHOULD BE ROUTED IN SEPARATE CONDUIT FROM ALL AC VOLTAGE SOURCES.

1. Always **disconnect power** before working on or near this equipment. Lock and tag the disconnect switch or breaker to prevent accidental power-up.
2. **There are multiple electrical connections** required for this control. **120V AC** should be wired to terminals **H1** and **N1**. If the hood is equipped with a separate light circuit, **120V AC** should power this circuit per the as-built schematic. **H1** and **N1** should not be connected to a shunt trip breaker.
3. The maximum distance between the CORE Protection System, PCU CORE Protection System, and a Hood CORE Protection System is 1000 feet. Shielded twisted pair cable must be used for this connection.
4. Verify that the power source is compatible with the requirements of your equipment. The system wiring schematic identifies the **proper phase and voltage** of the equipment.
5. Before connecting the control package to a power source, verify power source wiring is de-energized.
6. Secure the power cable to prevent contact with sharp objects.
7. Do not kink power cable and never allow the cable to come in contact with oil, grease, hot surfaces, or chemicals. Solenoid cables **must not** come in contact with hood surfaces.
8. **The supervised loop must be run through metallic conduit.** Do not run wiring with high voltage wires. Verify all supervised loop wires are free from damage/stress. All supervised loop wires must be terminated in terminal blocks, junction boxes, and push-stations.
9. If the system contains additional firestats, they must be wired into the supervised loop.
10. If the control package is a **wall-mount system**, a duct mounted temperature sensor will need to be wired. The temperature sensor must be wired to terminal blocks, as indicated on the wiring schematic.
11. If the control package is a **wall-mount system**, the hood lights wiring will need to be wired to terminals "B" and "W." Verify connections on wiring schematic.
12. Before powering up the system, make sure that the interior of the control package is free of loose debris or shipping materials.
13. If any original internal wire supplied with the system must be replaced, use type THHN wire or equivalent.
14. All field-supplied wire for the optional fire system release solenoid or firestat must be high temp wire rated for **842°F** minimum (#441601C6.FE9 White and #441601C6.FE0 Black).
15. The battery must be plugged in at connector J1 on the electrical board (PCBCORE) after wiring is complete.
16. All gas appliances under the hood must shut down in the event of an AC power loss. All electric appliances will shut down on building power loss.
17. Use Belden #6320UL, 18 Gauge, plenum-rated wire or similar, for the supervised loop that does not come in contact with the hood. Use Belden #88760 or similar for the fire system interlock network and CAT-5 for Modbus communications.
18. All exterior wiring connections to the PCU must be run inside liquid tight conduit. This includes the supervised loop and airflow switch wiring.

IMPORTANT!: The battery backup for the fire protection system produces output power even when main power is disconnected from system. When performing major electrical service to the control, the battery backup must be disconnected then reconnected before commissioning.

Wire Ampacity Rating

The load current rating and the over-current protection for conductor types shall not exceed 15 amperes for 14 AWG, 20 amperes for 12 AWG, and 30 amperes for 10 AWG aluminum and copper-clad aluminum after any correction factors for ambient temperature and number of conductors have been applied. Refer to **Table 9**.

Table 9 - Copper Wire Ampacity @ 75°C

Wire Size AWG	Maximum Amps
14	15
12	20
10	30
8	50
6	65
4	85

Distance Limitations

Wiring connections to remote fire protection system(s) must use shielded twisted pair wire. The maximum length of this connection is 1000 feet.

Wire size is an important consideration when making the connections between the fire protection system control package and a gas valve. Refer to **Table 10** for maximum wiring distance between the system and remote gas valve.

Table 10 - Wiring Maximum Distance

Wire Gauge	Distance (Feet)
12	1049
14	660
16	414
18	260
20	164
22	103
24	64

Fire Alarm Contacts

The fire protection system is equipped with optional normally open contacts (terminals **AL1** and **AL2**) for building applications that connect to the premise Fire Alarm Control Panel (FACP). Refer to **Figure 8** for wiring reference. During a fire condition, the contacts will close and trigger the premise FACP to initiate a general fire alarm.

Figure 8 - Fire Alarm Reference

1. Building Fire Alarm
2. Control Panel Fire Alarm Contact
3. End of Line Device
4. Alarm Input

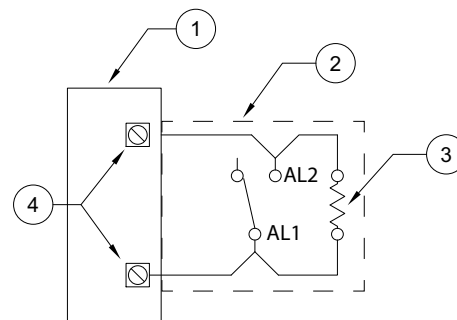

Fire Group

Fire Groups are for the purpose of using multiple CORE controlled fire systems and grouping specific fire systems together. This will allow the user the ability to assign different zones for independent activation.

In order to set a fire group, you will need to set the CORE board DIP switches as shown in **Table 11**.

Table 11 - Fire Group DIP Switch Position

6	7	Fire Group Number
Off	Off	1
On	Off	2
Off	On	3
On	On	4

Note: Every panel with matching fire group settings (DIP switches 6 and 7) will activate simultaneously in a fire condition.

Figure 9 shows an example of different zones on separate fire groups, but still connected via the interlock network. In the example, when 2 Fire groups (01 and 02) are assigned on the CORE boards, and if a fire condition exists in any one group, it will NOT activate the other fire group. However, both are connected to the same interlock network.

- Fire Group 01 CORE board DIP switch setting will be set to: Switch 6 Off and Switch 7 Off.
- Fire Group 02 CORE board DIP switch setting will be set to: Switch 6 On and Switch 7 Off.

Refer to “**Typical DIP Switch Arrangement**” on page 58 for setting multiple CORE controlled fire systems.

Figure 9 - Fire Group Reference

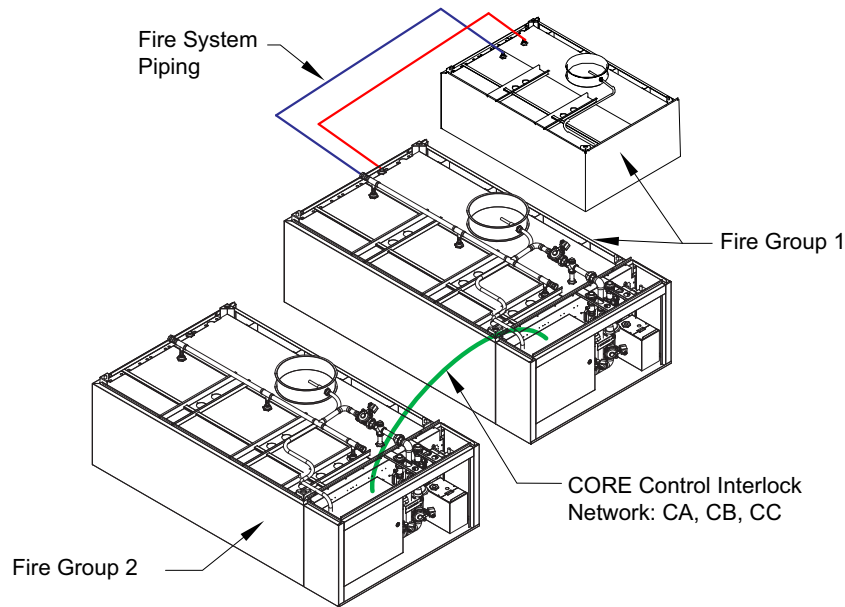

CORE Duct and Plenum Coverage

The CORE Protection System for Duct and Plenum coverage (**Figure 10**) can be utilized when specific appliances do not require total flood protection. When enclosed, appliances such as ovens are used duct and plenum coverage still offers protection for the plenum of the hood, as well as the ductwork.

IMPORTANT: All wiring between fire sensor and electrical control package that is on top of the hood must be high-temperature wire (842°F/450°C). Wire type MG or MGT, 16 gauge minimum.

Figure 10 - Duct and Plenum

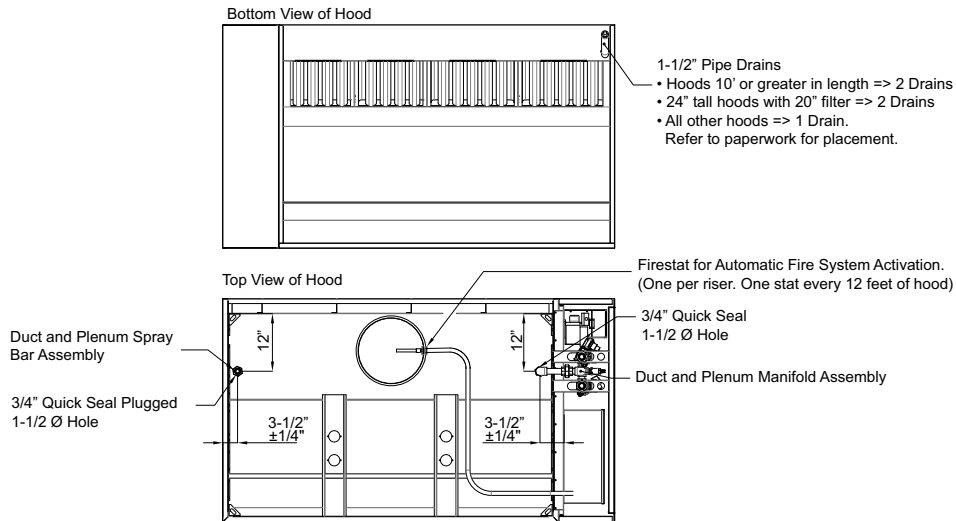

CORE Total Flood Coverage

The CORE Protection System for appliances depends on proper placement of the fire suppression nozzles. The fire system can be tailored to suit the individual needs of the appliances. The overall cooking surface of the appliances under the hood are called the hazard zone and will determine the fire protection system. It is important to remember that the nozzles will need an unobstructed path to the hazard zone for proper fire suppression.

Hazard Zone and Nozzle Placement

The Hazard Zone consists of the cooking surface of each appliance underneath each hood. All appliances outlined in UL300 and on the chart on the following page are suitable to be covered with the CORE total flood system. There are specific branch appliance drop requirements for upright charbroilers and salamanders. The lowest and highest cooking surface will determine the height of the fire suppression nozzles. This nozzle height can range between 30 and 55 inches. For applications where the appliance is vertical, such as an upright charbroiler, the nozzle setup will need to be adjusted. The sections below contain more detailed information about the Total Flood system.

Proper placement of the appliance hazard zone will maximize the performance of the fire system. There are several factors that need to be accounted for when placing the appliances under the fire system, such as the front and side overhang measurements of the hoods with respect to the hazard zone, and the appliance clearances to combustibles. The common line placement will depend on where the appliance hazard zone is installed under the hood. The common line is a 3/4" NPT line typically installed 24" off the back of the hood and will supply the nozzles. This line can be extended to additional CORE Protection hoods to continue the coverage of the hazard zone to a maximum of 48 feet.

The nozzles must be positioned along the hood length to allow Total Flood of each appliance in the hazard zone. The nozzles must be no more than 12" away from the end of the hazard zone, and the nozzles cannot be spaced further than 36" from each other. The nozzle must be no more than 18" away from the front or back of the hazard zone. The pipe for the nozzle drops cannot be sleeved in stainless steel, but can be made from polished stainless-steel or polished chrome-plated black iron. Refer to **Figure 4 on page 12**.

Appliance Coverage

The maximum permitted hazard zone depth to be covered by one row of CORE Protection nozzles for each individual appliance is shown in **Table 12**. Multiple or larger appliances may be covered under alternate nozzle configurations of the CORE Total Flood system. The maximum length of the hazard zone is 48 feet. It is important to note that the hazard zone is different than the appliance size. Examples of nozzle placements for CORE Total Flood are shown on **page 21** through **page 29**.

Table 12 - Appliance Coverages

Hazard	Fuel Source	Maximum Depth of Hazard Zones	Maximum Length of Hazard Zones	Maximum Height of Fuel
Deep Fat Fryer (with or without dripboard) ^{(3) (8)}	Gas or Electric	36" deep	Unlimited	N/A
Multi Vat Fryer (with or without dripboard) ⁽³⁾	Gas or Electric	36" deep	Unlimited	N/A
Split Vat Fryer (with or without dripboard) ⁽³⁾	Gas or Electric	36" deep	Unlimited	N/A
Griddle	Gas or Electric	36" deep	Unlimited	N/A
Charbroiler (Radiant or Standard)	Gas or Electric	36" deep	Unlimited	N/A
Up-Right Charbroiler (Upright, Salamander, Chain)	Gas or Electric	36" deep	Unlimited	N/A
Cook Range (with or without back shelf) ⁽⁵⁾	Gas or Electric	36" deep	Unlimited	N/A
Natural Charcoal Broiler ⁽⁶⁾	Charcoal	36" deep	Unlimited	8"
Solid Fuel Charbroiler ⁽⁶⁾	Mesquite or Hardwood	36" deep	Unlimited	8"
Lava Rock Charbroiler ⁽⁶⁾	Gas or Electric	36" deep	Unlimited	8"
Wok ⁽⁷⁾	Gas or Electric	11" - 20" diameter	11" - 20" diameter	5-1/4"

- All dimensions in **Table 12** are based off total flood overlapping protection.
- All dimensions and areas shown reference the hazard zone of the appliance, which is typically smaller than the outside dimensions of the appliance itself.
- Deep Fat Fryers, Multi Vat Fryers, and Split Vat Fryers are permitted to have a drip-board. Nozzle height(s) for fryers should be taken from the fryer's maximum level indicator.
- Deep Fat/Tilt Skillets will be standard overlapping, 36" max nozzle spacing. Max oil capacity: 24.75 gallons. If the oil capacity exceeds 24.75 gallons, refer to **page 29**.
- The Cook Range may have an integral back shelf that protrudes no more than 12 inches from the back of the appliance. The shelf is to be at least 18 inches above the hazard zone. The hazard zone of the range is defined as the raised portion of the appliance grating encompassing the burners as identified on **page 24**. The grating dimension may extend beyond this point.
- Dimensions above for the Natural Charcoal Broiler, Solid Fuel Charbroiler, and Lava Rock Charbroiler are referencing the metal housing containing the fuel source. All solid-fuel appliances must have additional firestats mounted near the fan. If the duct run is longer than 10 feet or horizontal, refer to **page 62**.
- If a Wok exceeds 20", Large Wok coverage must be used. Large Wok Coverage is for protection of Wok sizes greater than 20" and up to 24" in diameter, with a maximum fuel depth of 6.75". Refer to **page 26**.
- Protection for Tilt Skillets and Braising Pans are to be based on the coverage limitations provided for deep fat fryer appliance protection. When the depth exceeds the maximum listed size for single row protection, an additional row of nozzles may be used to provide proper coverage.

Standard Overlapping Protection

Standard overlapping protection allows up to 36" max nozzle spacing. All overlapping nozzles must be spaced no more than 12" from each end of the appliance, located at the centerline of the 36" cooking surface (front to back), at the same height, and aimed straight down. The nozzle height must be 30" to 55" above the appliance cooking surface, except for woks, where the height is measured 3 inches below the top rim of the wok. The nozzles must be positioned along the total cooking surface length to allow protection of each appliance in the hazard zone.

1. Pipe and fittings above the hood, after the second CORE solenoid will be 1" copper pipe and 1" copper Pro-press fittings with EPDM seals, unless otherwise noted.
2. Pipe and fittings inside the hood capture volume will be 3/8" NPT stainless-steel or chrome-plated black iron. No sleeving permitted.
3. Overlapping Female Nozzle Part Number: OL-F (previously p/n 3070-3/8H-10-SS).
4. Nozzle heights above cooking surface (DIM A) Min 30"/Max 55".
5. Install drops at 36" maximum spacing. If the hazard zone contains separations not covered by the fire system, install a quick seal and stainless steel plug to support the spray bar.
6. Drops must be installed with an internal pipe wrench, or another non-marring pipe tool.
7. Appliance drop fittings may be sealed with pipe dope or Teflon tape.
8. Nozzle height(s) for fryers should be taken from the fryer's maximum level indicator.

Figure 11 - Standard Overlapping Protection Details

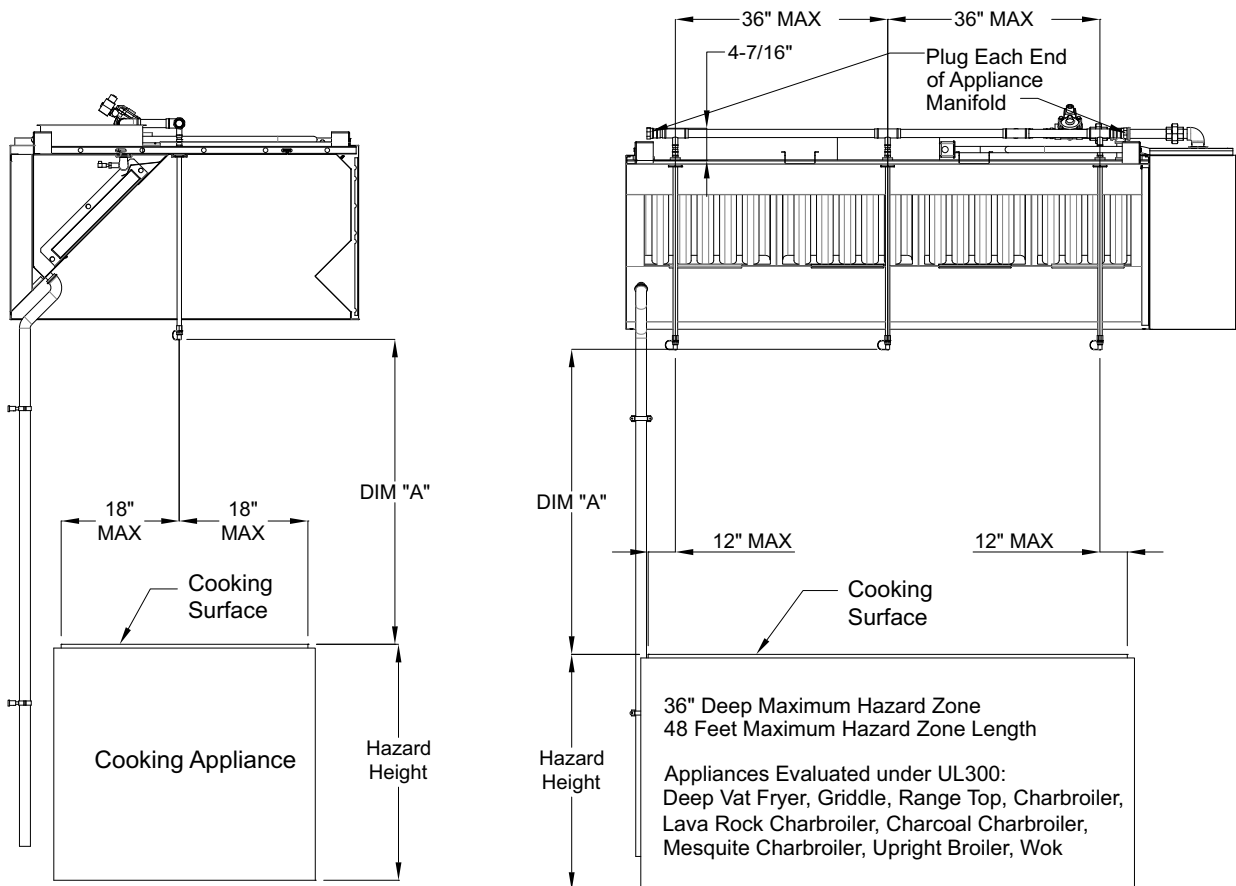

Appliance Spray Bar

1. Pipe and fittings above the hood, after the second CORE solenoid will be 1" copper pipe and 1" copper Pro-press fittings with EPDM seals, unless noted otherwise.
2. Pipe and fittings inside the hood capture volume will be 3/8" NPT stainless steel or chrome-plated black iron. No sleeving permitted.
3. Polished pipe and fittings must be installed with an internal pipe wrench or another non-marring pipe tool.

Figure 12 - Appliance Spray Bar Details

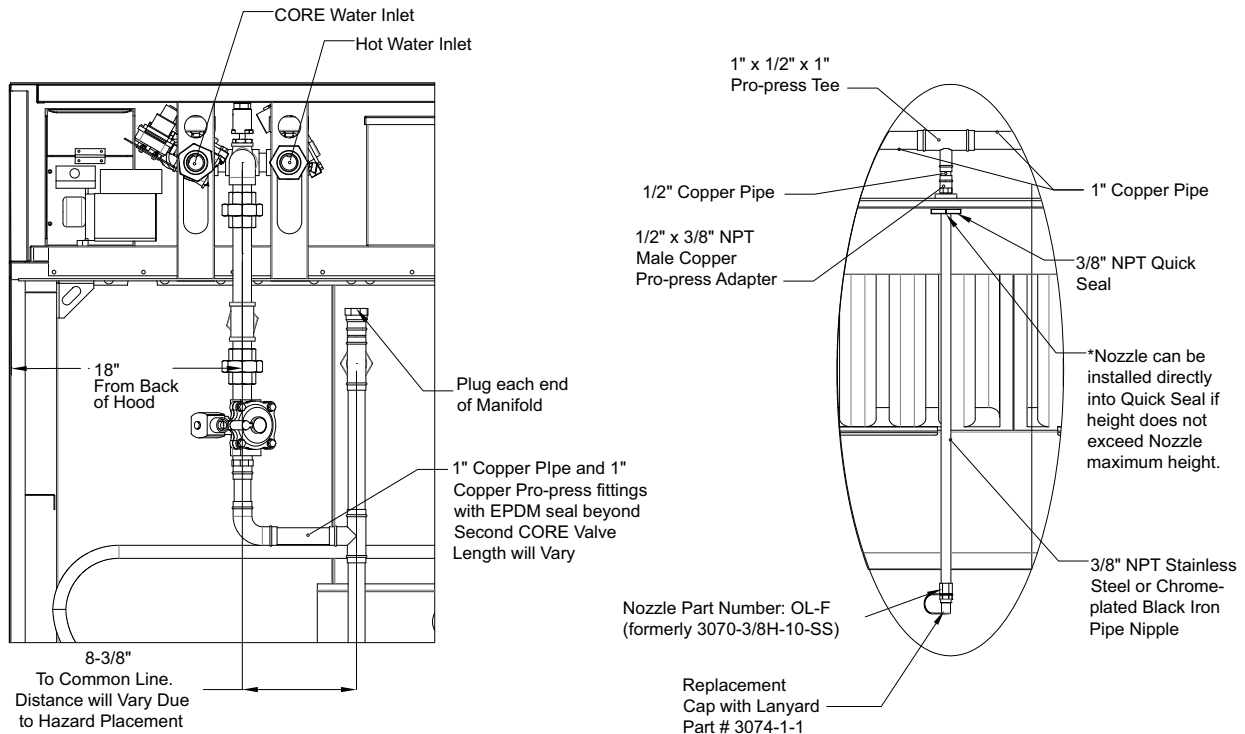

Upright Broiler Protection

Upright broilers, chain broilers, and cheese-melters have specific coverage requirements. Unlike appliances with an exposed flat cooking surface, these appliances have an internal cooking surface and only have a small opening in the face or end of the appliance.

To cover the internal hazard posed by these appliances, a nozzle must be placed at the opening and aimed at the opposite rear corner of the appliance. This nozzle must be branched off one of the nozzle drops and piped to the appliance opening. The drawing below illustrates how this should be accomplished. Should the cooking surface of the appliance exceed 675 in², an additional nozzle will be required on the opposite of the appliance for added fire protection. Each nozzle can cover 675 in².

1. Pipe and fittings above the hood, after the second CORE solenoid will be 1" copper pipe and 1" copper Pro-press fittings with EPDM seals, unless otherwise noted.
2. Pipe and fittings inside the hood capture volume will be 3/8" NPT stainless-steel or chrome-plated black iron. No sleeving permitted.
3. Overlapping Female Nozzle Part Number: OL-F (previously p/n 3070-3/8H-10-SS).
4. Nozzle heights above cooking surface (DIM A) Min 30"/Max 55".
5. In addition to Standard Overlapping Protection, additional nozzles may be utilized for supplemental appliance specific protection. No more than two (2) nozzles may be used on a single drop.
6. Appliance drop fittings may be sealed with pipe dope or Teflon tape.

Figure 13 - Upright Charbroiler/Salamander Protection

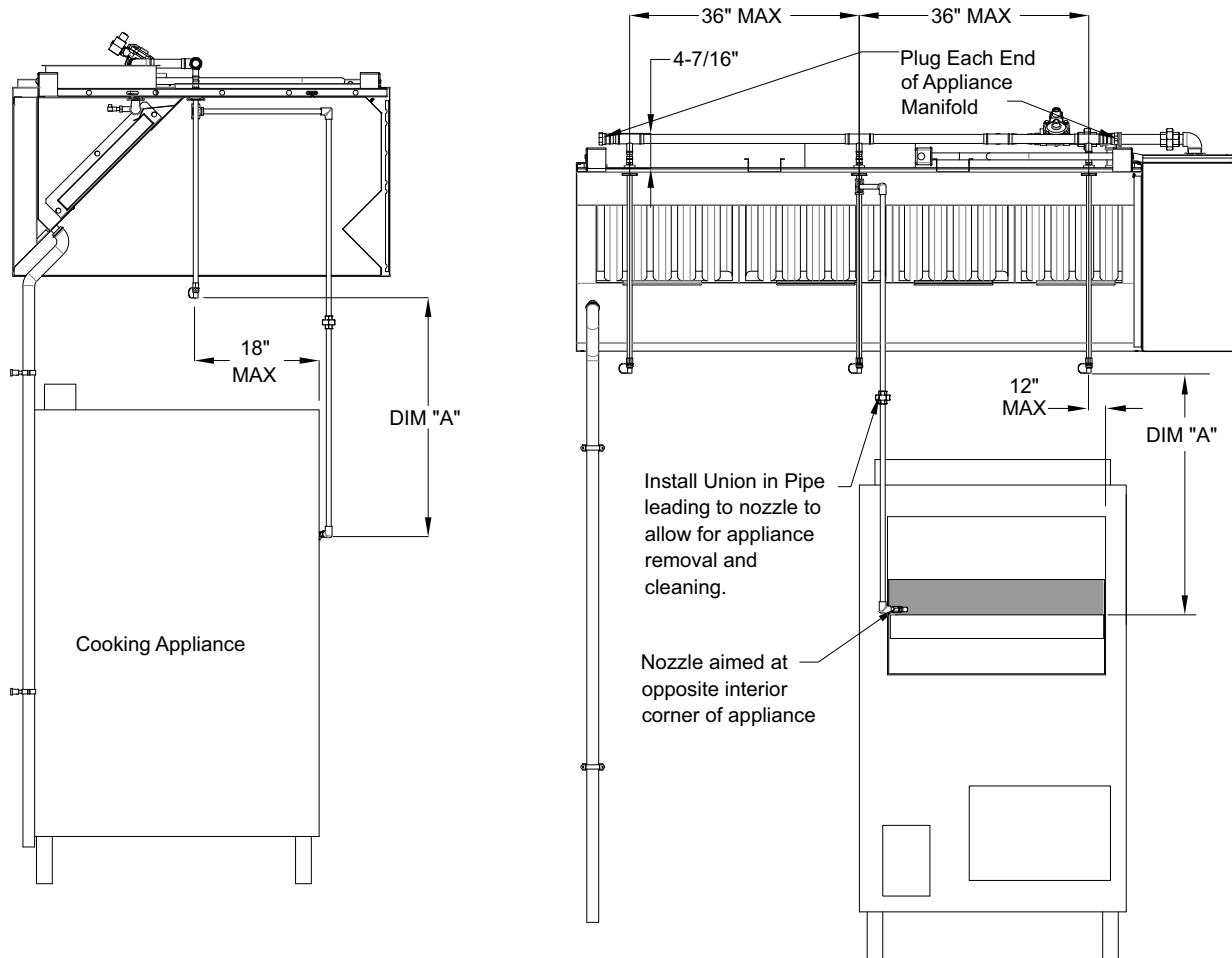

Wok Protection

Nozzle for Wok protection must be located within 12" from the left or right of the Wok and 18" from the front or back of the Wok. The Wok diameter range for CORE protection is 11" to 20" diameter.

1. Pipe and fittings above the hood, after the second CORE solenoid will be 1" copper pipe and 1" copper Pro-press fittings with EPDM seals, unless otherwise noted.
2. Pipe and fittings inside the hood capture volume will be 3/8" NPT stainless-steel or chrome-plated black iron. No sleeving permitted.
3. Overlapping Female Nozzle Part Number: OL-F (previously p/n 3070-3/8H-10-SS).
4. Nozzle heights above cooking surface (DIM A) Min 30"/Max 55".
5. Appliance drop fittings may be sealed with pipe dope or Teflon tape.

Figure 15 - Wok Diameter Protection (up to 20")

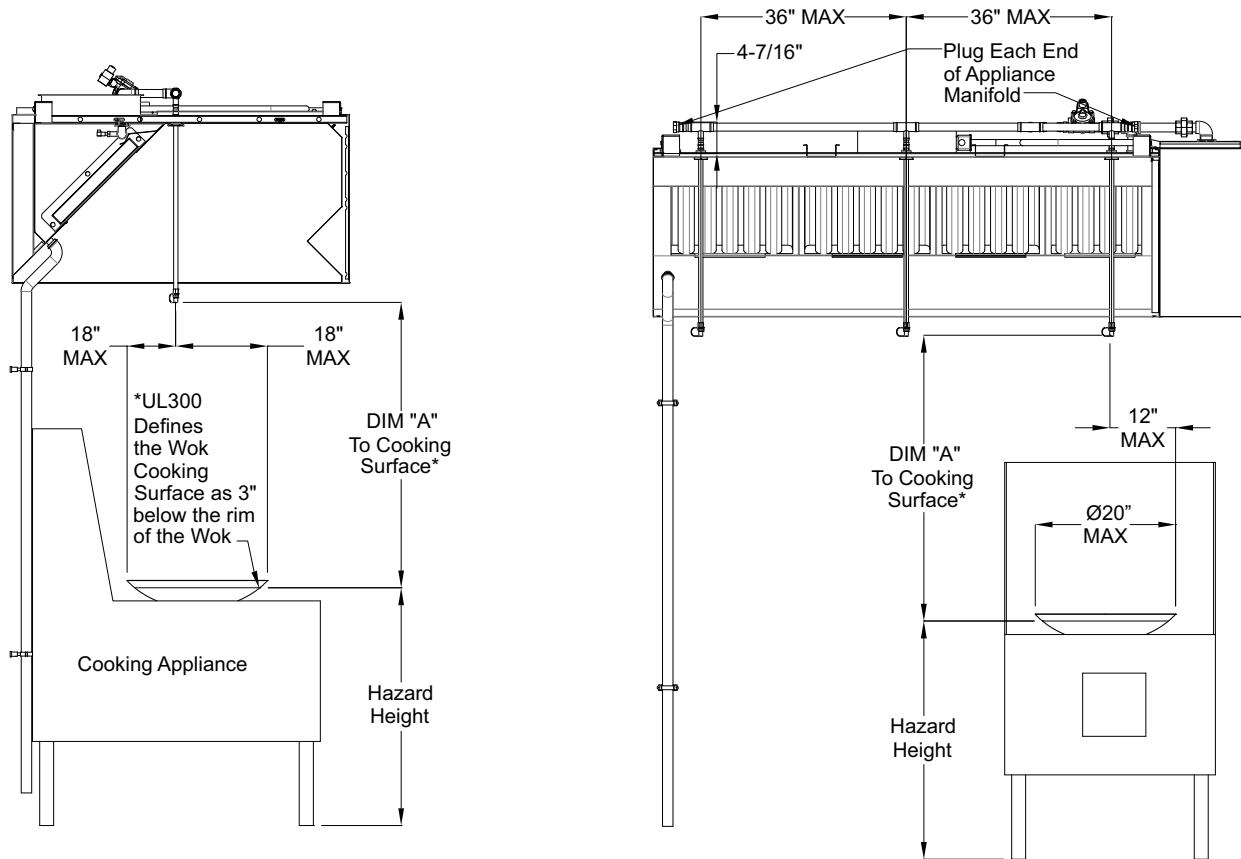

Large Wok Protection

Standard overlapping protection must be in place following the same guidelines for standard Wok Coverage. Overlapping Nozzle for Wok protection must be located within 12" from the left or right of the Wok and 18" from the front or back of the Wok.

Appliance specific protection is required for a Wok with a diameter larger than 20", not to exceed 24", with a maximum fuel depth of 6.75" protection. The appliance specific coverage includes two (2) WK-F nozzles, spaced 4" to 6" apart, located inside of the wok outer circumference. This nozzle arrangement is to be located 30" from the Wok cooking surface, defined in UL300 as 3" below the rim of the Wok.

1. Pipe and fittings above the hood, after the second CORE solenoid will be 1" copper pipe and 1" copper Pro-press fittings with EPDM seals, unless otherwise noted. Pipe and fittings inside the hood capture volume will be 3/8" NPT stainless-steel or chrome-plated black iron. No sleeving permitted.
2. Overlapping Female Nozzle Part Number: OL-F (previously p/n 3070-3/8H-10-SS).
3. Wok Female Part Number: WK-F (previously p/n 3070-3/8H-00120-SS).
4. Nozzle heights above cooking surface (DIM A) Min 30"/Max 55".
5. In addition to Standard Overlapping Protection, additional nozzles may be utilized for a wok diameter larger than 20", not to exceed 24". No more than two (2) nozzles may be used on a single drop.
6. Appliance drop fittings may be sealed with pipe dope or Teflon tape.

Figure 16 - Large Wok Diameter Protection (greater than 20", not to exceed 24")

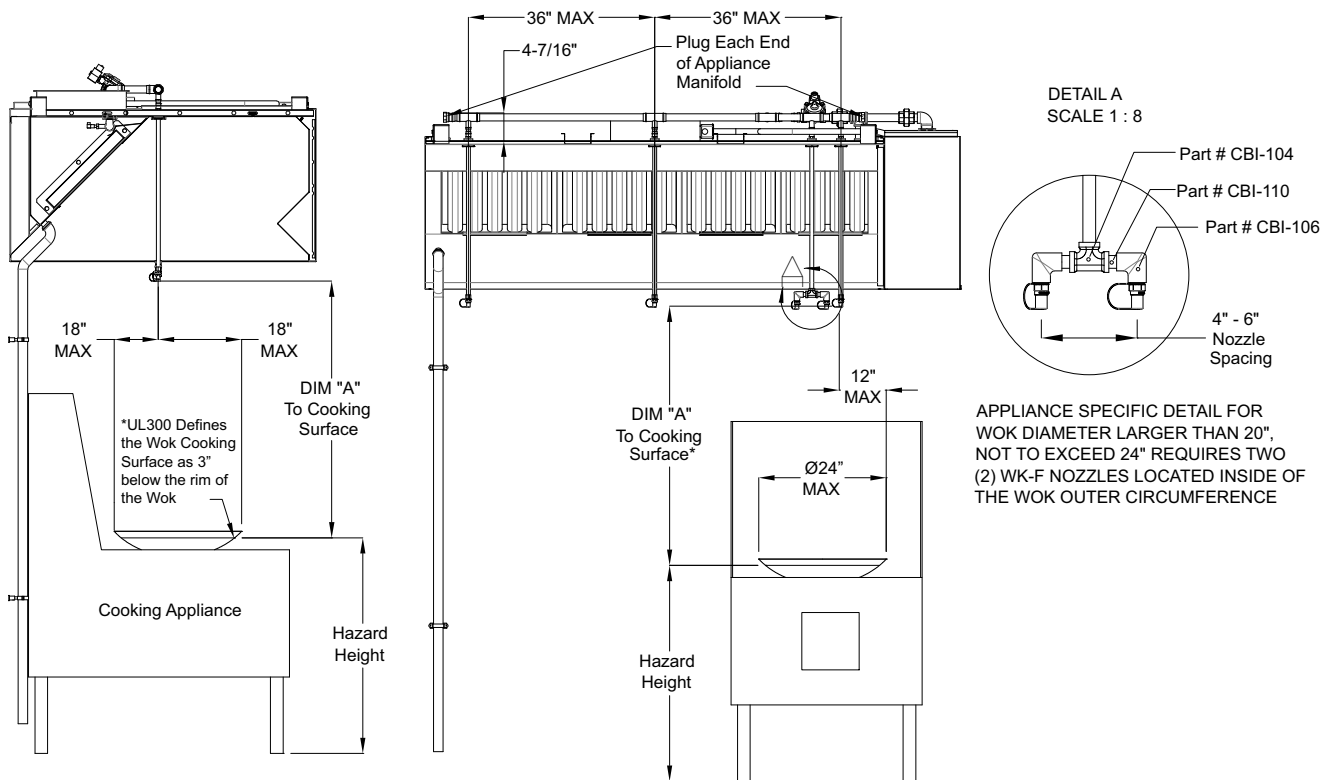

Salamander Protection

Salamanders have specific coverage requirements, unlike appliances with an exposed flat cooking surface, these appliances have an internal cooking surface and only have a small opening in the face or end of the appliance.

To cover the internal hazard posed by these appliances, a nozzle must be placed at the opening and aimed to the opposite rear corner of the appliance. This nozzle may be branched off one of the nozzle drops with a tee or have a dedicated nozzle drop and piped to the appliance opening. No more than two nozzles can be utilized for a single drop. Should the cooking surface of the appliance exceed 675 in², an additional nozzle will be required on the opposite side of the appliance for added fire protection. Each nozzle can cover 675 in².

Additional nozzles may be piped from nozzle drops nearest the appliance, or have a dedicated nozzle drop to cover the hazard underneath the salamander. These nozzles are aimed at the centerline of the cooking surface, a minimum of 30" away.

1. Pipe and fittings above the hood, after the second CORE solenoid will be 1" copper pipe and 1" copper Pro-press fittings with EPDM seals, unless otherwise noted.
2. Pipe and fittings inside the hood capture volume will be 3/8" NPT stainless-steel or chrome-plated black iron. No sleeving permitted.
3. Overlapping Female Nozzle Part Number: OL-F (previously p/n 3070-3/8H-10-SS).
4. Nozzle heights above cooking surface (DIM A) Min 30"/Max 55".
5. In addition to Standard Overlapping Protection, additional nozzles may be utilized for supplemental appliance specific protection. No more than two (2) nozzles may be used on a single drop.
6. Appliance drop fittings may be sealed with pipe dope or Teflon tape.

Figure 17 - Salamander Protection Details

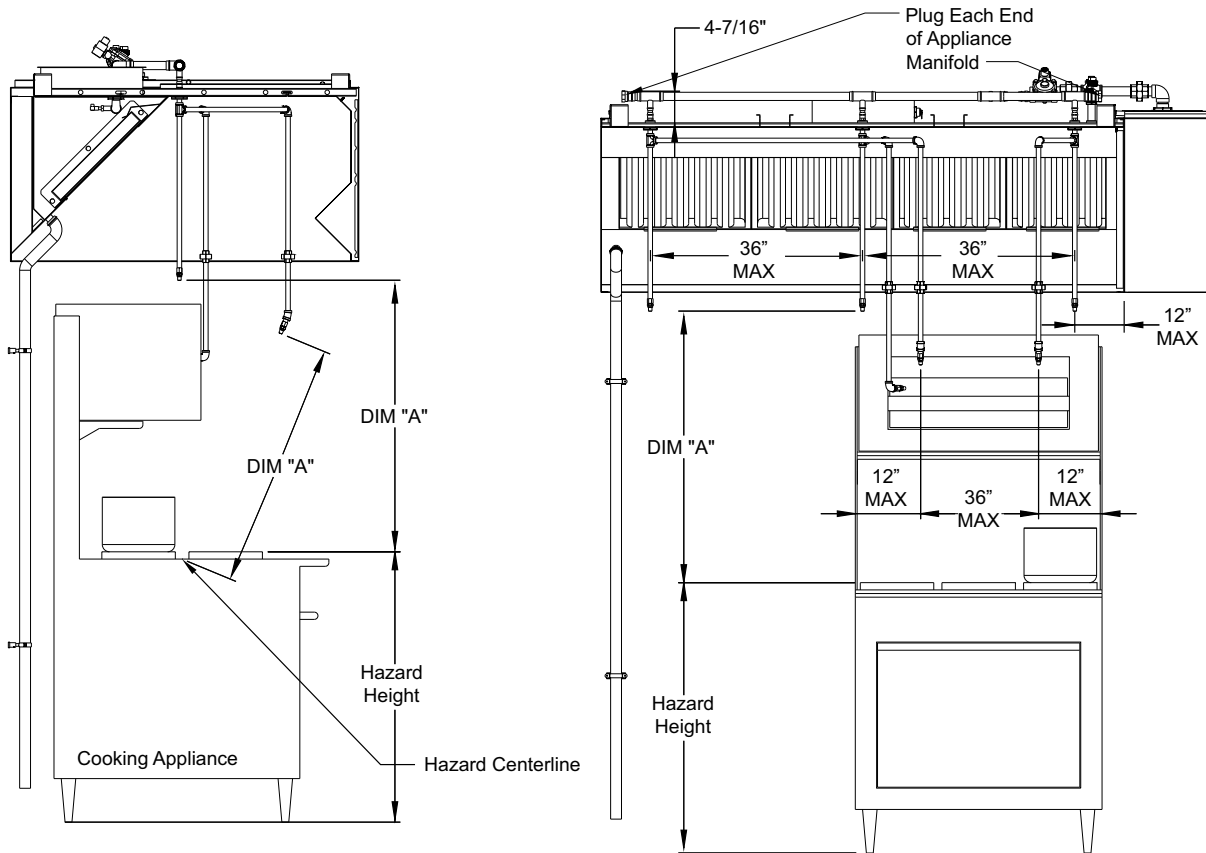

Large Appliance Protection

When the depth of the appliance's hazard zone exceeds the listed coverage on **page 20**, it can be covered by doubling the row of overlapping protection. By doubling the rows of overlapping protection, a greater surface area can be protected. When providing protection for large solid-fuel appliances a secondary row of nozzles will be required when:

- Gas or Electric fuel source appliances, excluding lava rock charbroilers, hazard zones that exceed 36" in depth will require a secondary row of appliance protection.
 - Solid fuel source appliances (lava rock, mesquite, hardwood, and/or charcoal) hazard zones that exceed 36" in depth will require a secondary row of appliance protection.
1. Pipe and fittings above the hood, after the second CORE solenoid will be 1" copper pipe and 1" copper Pro-press fittings with EPDM seals, unless otherwise noted.
 2. Pipe and fittings inside the hood capture volume will be 3/8" NPT stainless-steel or chrome-plated black iron. No sleeving permitted.
 3. Overlapping Female Nozzle Part Number: OL-F (previously p/n 3070-3/8H-10-SS).
 4. Nozzle heights above cooking surface (DIM A) Min 30"/Max 55".
 5. Install drops at 36" maximum spacing. If the hazard zone contains separations not covered by the fire system, install a quick seal and stainless-steel plug to support the spray bar.
 6. Drops must be installed with an internal pipe wrench, or another non-marring pipe tool.
 7. Appliance drop fittings may be sealed with pipe dope or Teflon tape.

Figure 18 - Large Appliance Protection Details

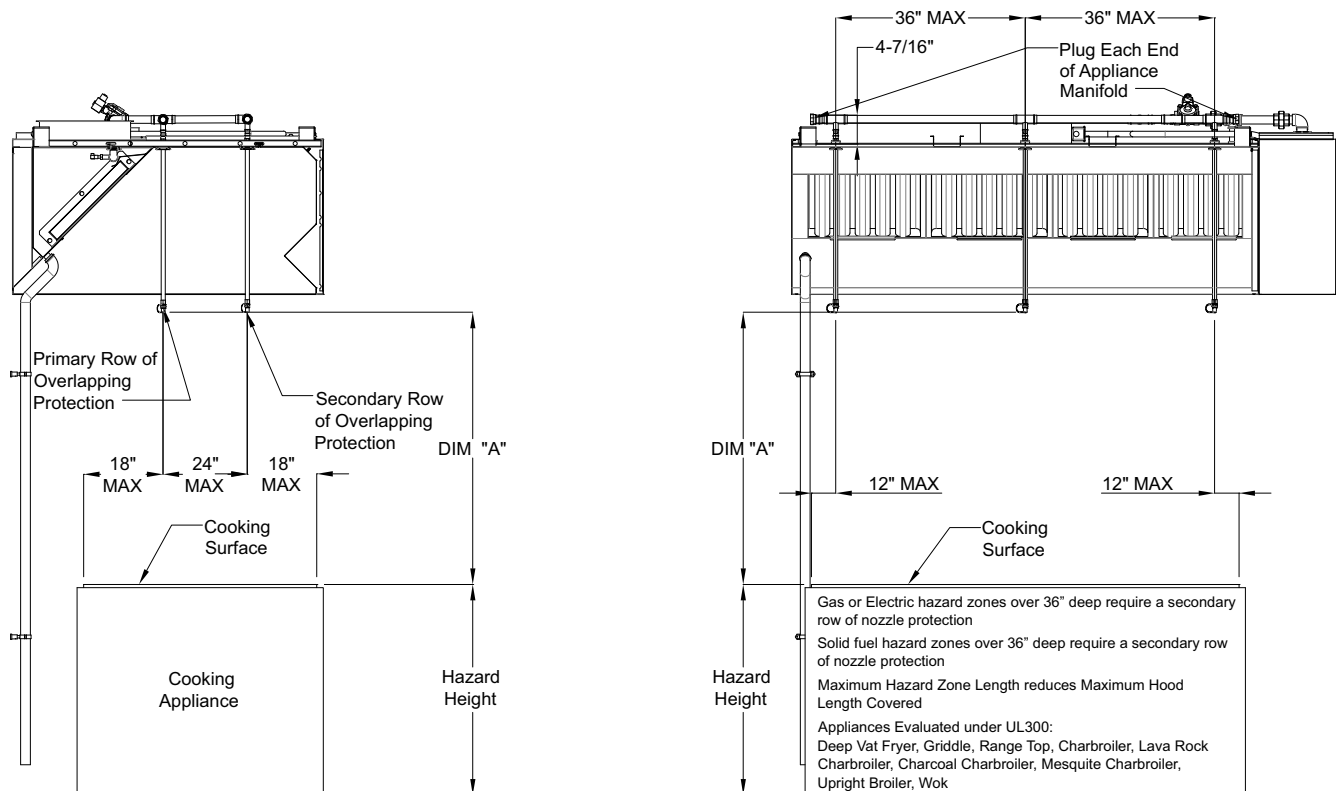

Large Industrial Fryer Protection

When providing protection for large industrial fryers, the nozzles are to be spaced no greater than 24" in a row, rows are spaced no more than 24" apart. Large Industrial Fryer coverage is limited to CORE manifolds 1" and 1-1/2" in size, and appliances with a capacity no greater than 80 gallons.

When providing protection for large solid-fuel appliances, coverage is limited to CORE manifolds 1" and 1-1/2" in size. A double row of protection will be provided for all large solid-fuel appliances, regardless of the appliance depth.

1. Pipe and fittings above the hood, after the second CORE solenoid will be 1" copper pipe and 1" copper Pro-press fittings with EPDM seals, unless otherwise noted.
2. Pipe and fittings inside the hood capture volume will be 3/8" NPT stainless-steel or chrome-plated black iron. No sleeving permitted.
3. Overlapping Female Nozzle Part Number: OL-F (previously p/n 3070-3/8H-10-SS).
4. Nozzle heights above cooking surface (DIM A) Min 30"/Max 55".
5. Install drops at 24" maximum spacing. If the hazard zone contains separations not covered by the fire system, install a quick seal and stainless-steel plug to support the spray bar.
6. Drops must be installed with an internal pipe wrench, or another non-marring pipe tool.
7. Appliance drop fittings may be sealed with pipe dope or Teflon tape.

Figure 19 - Large Fryer Protection Details

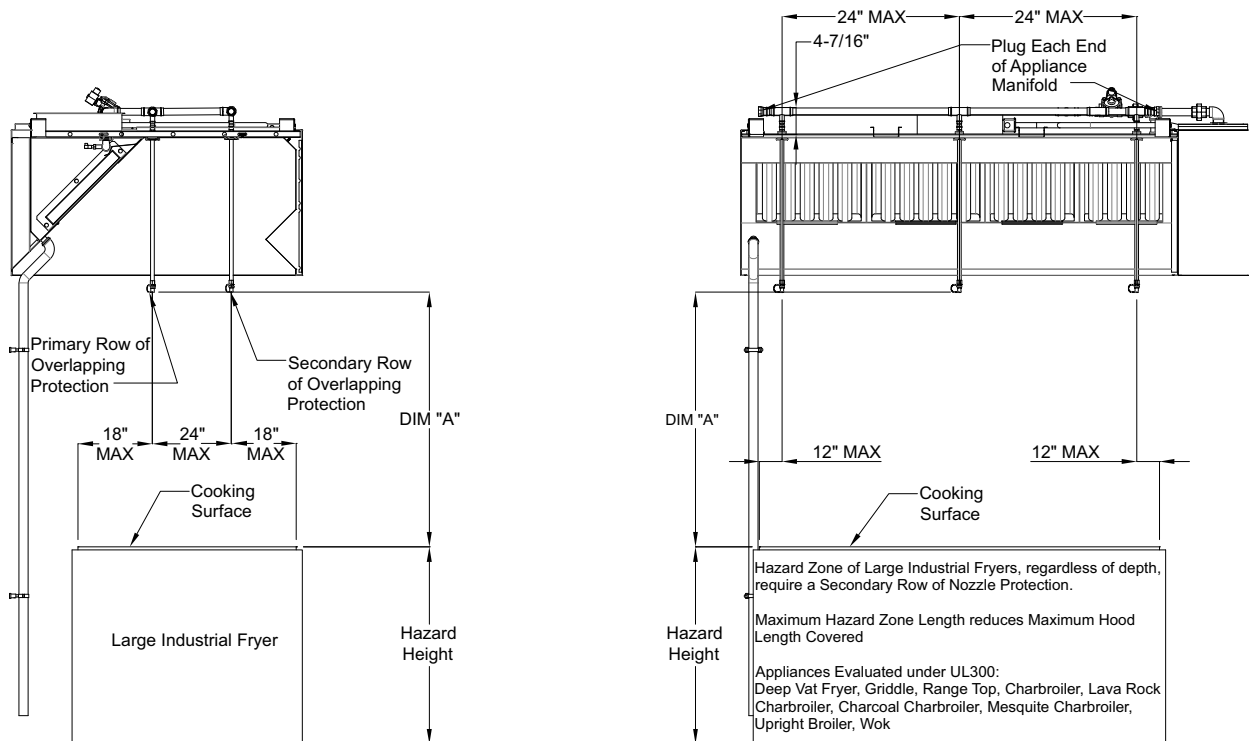

OPERATION

Prior to starting up or operating the system, check all fasteners for tightness. Ensure that the wiring is installed properly and that all nozzles and panels are installed.

Self Cleaning Hood

The self cleaning hood is designed to use hot water to wash the hood plenum and immediate duct section every time the fan switch is switched from the “ON” position on the main control panel. When the switching action occurs, hot water sprays along the entire length of the hood and towards the back of the hood for a factory setting of 3 minutes. During this time, surfactant is injected into the water stream for a duration of 1 second for each minute of wash time. Once the wash cycle is complete, water stops spraying, and the hood filters are to be removed and cleaned.

Self Cleaning System Overview

In self cleaning mode, the hot water solenoid opens, allowing hot water to flow to the duct and plenum of the hood. Surfactant is injected at a rate of one second per minute of wash. The diagram below shows the Hot Water side of the wall-mounted manifold that is activated during the “wash” cycle. The CORE sprinkler water solenoid remains closed during the wash cycle.

Figure 20 - Wall Mount CORE Manifold, Hot Water Flow

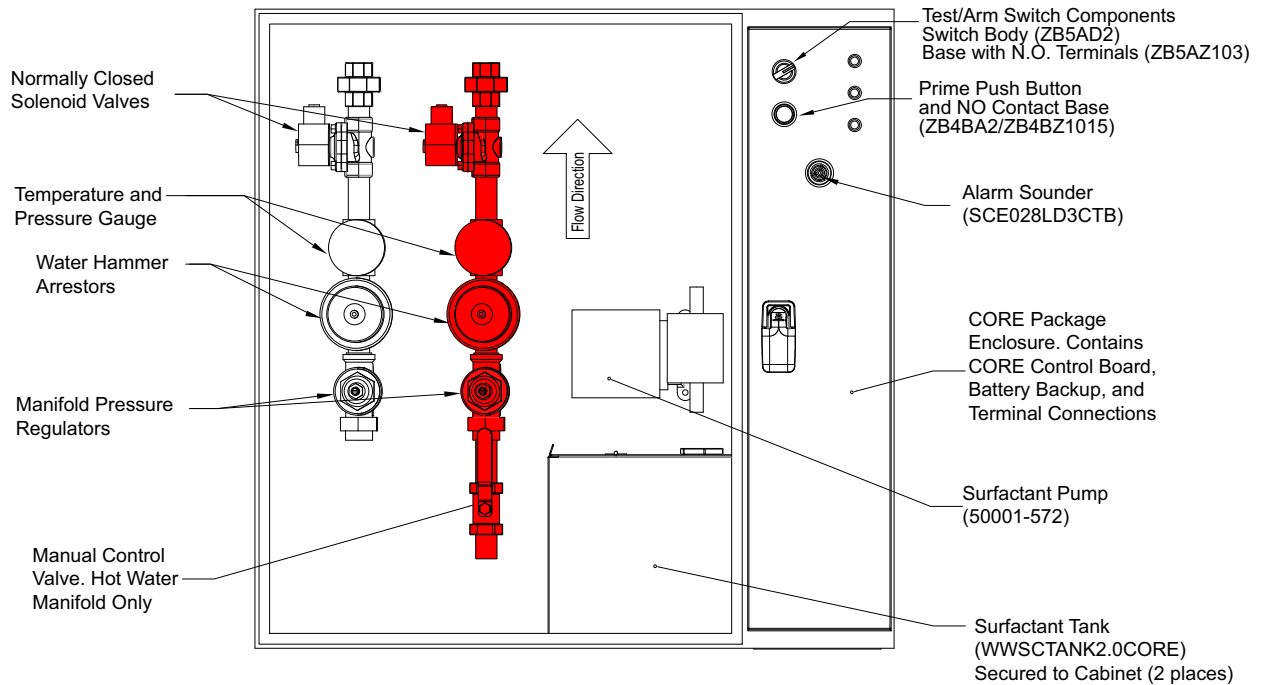

The appliance solenoid remains closed on top of the hood preventing hot water from spraying on the appliances. Hot Water only flows to the duct and plenum area during the self cleaning cycle.

Figure 21 - Top of Hood Connection for Wall Mount CORE Manifold, Hot Water Flow

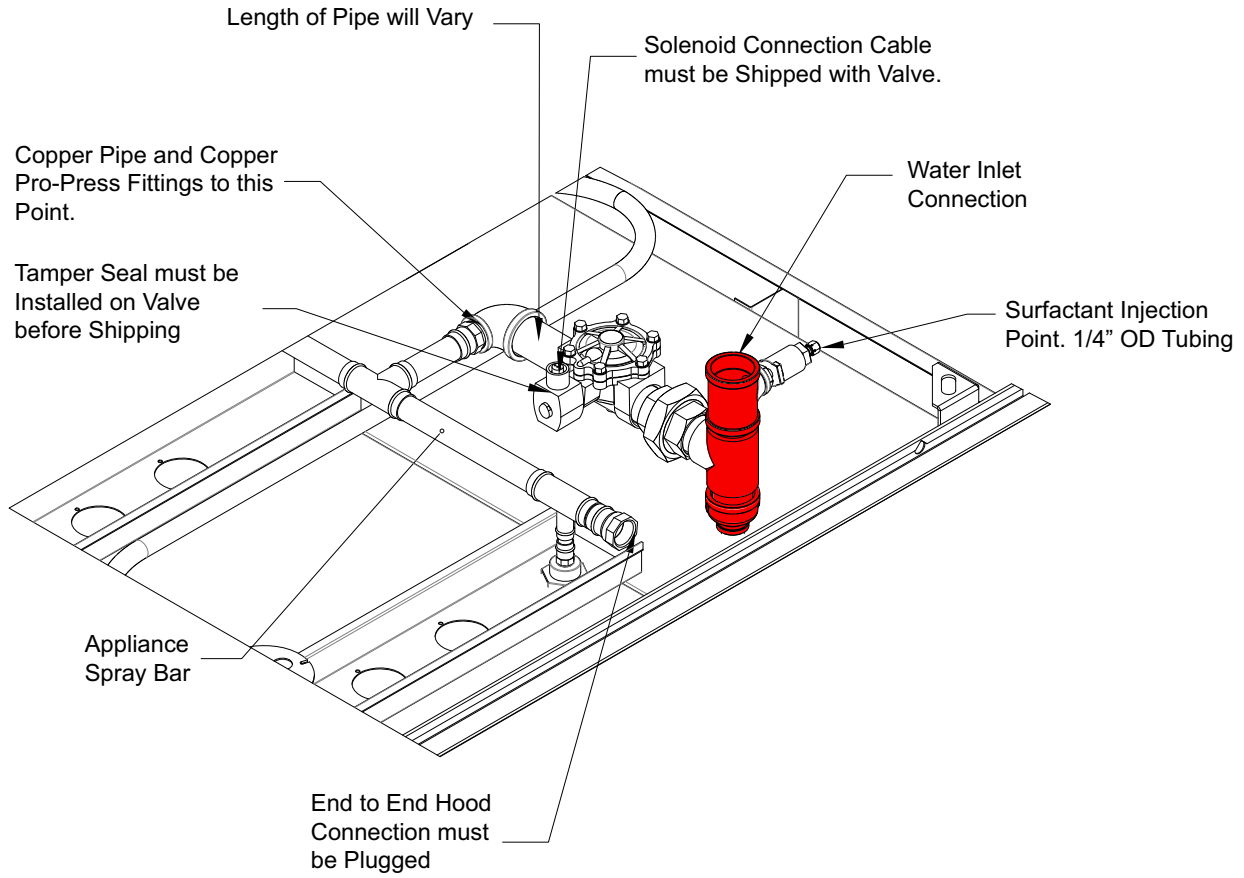

Self Cleaning Hood Start-up

Special Tools: AC Voltage Meter, Standard Hand Tools, Hand-held Heat Source, Surfactant (Part Number WWDETER for 4 Gallons, WWDETER-1G for 1 Gallon), High-Temperature Wire for Supervised Loop on Hood (Type MG, White Part Number 441601C6.FE9, Black Part Number 441601C6.FE0), Supervised Loop Wire for Off Hood Connections (Belden Part Number 6320UL or similar).

Jobsite Qualifications – Pre-installation Self Cleaning Hood

1. Verify the proper amount of water pressure and flow rate is available for self cleaning. If the operating and static pressures exceed maximum listing, identify and size a pressure reducing valve.
2. Determine the pressure drop from the connection at the source to the connection at the self cleaning manifold inlet.
3. Verify the location of the manifold, and if a backflow preventer is required.
4. Verify hot water minimum temperature rating of 140°F will be provided.

Start-Up Procedure – Self Cleaning Hood

1. Check all nozzles to make sure they are installed and tight.
2. Install all hood filters per the filter installation configuration, see **Figure 23 on page 33**. There are drip blanks secured to the filters to prevent water from exiting the hood between the filters.
3. Open all water valves to the hood.
4. Fill surfactant tank with surfactant. The “Add Surfactant” light should not be on, once the tank is full. Prime the surfactant pump with the push-button on the face of the electrical control package.
5. There are 2 timers that control the water wash spray and the surfactant injection. The wash timer is set to 3 minutes from the factory. The surfactant timer that is fixed and factory set for 1 second of injection during each minute of wash time. The injection occurs at the start of each minute. The Wash timer setting should be verified. For more detailed information on HMI navigation and settings, refer to the provided **Demand Control Ventilation** manual.
6. Turn the hood fan switch to the “ON” position. Fans should operate. If they do not, check wiring. If the hood has the cold water mist option, cold water should begin to spray.
7. To operate the wash cycle, simply turn the fan switch off. The wash cycle energizes automatically and will remain on for the duration of the wash timer setting. The wash cycle may not run if the minimum fan run time has not been met.
8. Verify that the surfactant is properly injected into the water stream.
9. Verify the pressure and temperature of the water via the pressure/temperature gauge (**Figure 22**). Self Cleaning pressure should be between the required minimum psi, refer to **Table 3 on page 9** through **Table 7 on page 11**. The maximum operating pressure cannot exceed 70 psi.
10. Check all manifold pipe connections to ensure there are no water leaks.
11. Check all filters to make sure that no water is leaking back through the filters.
12. Verify that the hood grease trough is draining properly and there are no clogs in the drain.

Figure 22 - CORE Pressure/Temperature Gauge

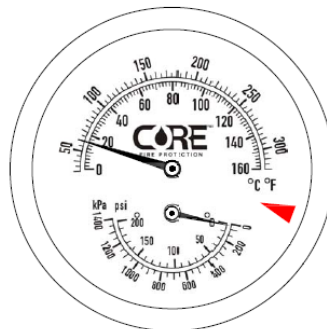

Filter Installation Configuration

The hood filters have drip blanks attached to them to prevent water leakage through the filters. **Figure 23** shows the location of the drip blanks and the last filter to be installed into the hood.

NOTE: Hoods with self cleaning filters do not have drip blanks installed.

Figure 23 - Filter Installation Chart

NOTE: Blue Filters designated the last filter that is installed in the hood.

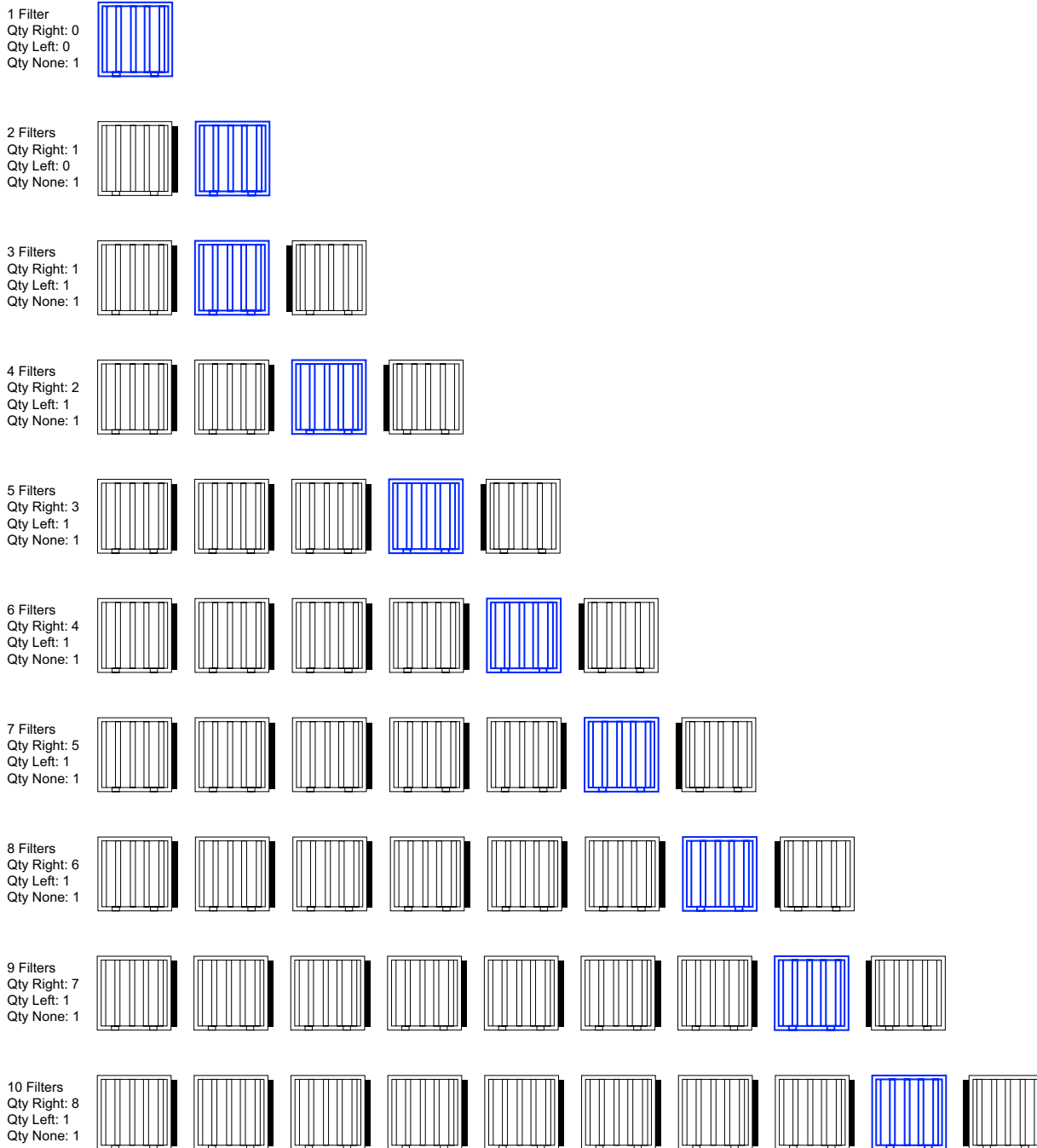

CORE Protection Fire System

A self cleaning hood is required to be installed to achieve CORE Protection. The basic daily operation of the CORE Protection system is identical to the self cleaning hood. In the event of a hood fire, CORE Protection will activate.

If the Firestat installed in the riser senses a temperature hotter than its internal setpoint, or if the remote manual actuation device (push/pull station) is pushed, an electric signal is sent to the appliance protection fire system solenoid and the hood duct and plenum water system solenoid. The two electric water solenoids energize, allowing the flow of water to the hood duct and plenum and the appliance nozzles. At the same time, the surfactant is continually injected into the water stream to help suppress the fire.

Once the fire system is activated, a "Fire System Activated" light is illuminated on the hood control panel and an audible alarm sounds. All gas and electric appliances under the hood must be electrically interlocked to shut off. This is achieved via a gas valve relay and/or a shunt trip breaker. A timer is also energized upon fire system activation. The timer is factory set for 15 minutes and keeps the duct and plenum water spray system running for a minimum of 15 minutes. The same timer also keeps the appliance water spray running for a minimum of 15 minutes. This is necessary to ensure all fire potentials are completely extinguished.

The fire system is electrically operated and thus requires a battery backup system. In the event of a loss of building electrical power, all gas and electric appliances under the hood must be electrically interlocked to shut off. This is achieved via a gas valve relay and/or a shunt trip breaker. The battery backup will automatically energize upon a loss of power. The battery backup will monitor the fire system circuit for up to 24 hours and be able to operate the fire system circuit for a minimum of 30 minutes. Once power is restored, the battery will automatically recharge.

CORE Protection Test Mode Overview

The fire protection system has an integrated option for testing. This test mode, when active, will shut down the appliance coverage solenoid and prevent the water from spraying on the appliances. It will allow activation of the fire system, including the water spray in the duct and plenum, audible alarm, shunt trip breaker (if applicable), and shut down of appliances via gas valve reset relay. This mode will also activate any additional CORE package attached to the system, including any Pollution Control Unit CORE Protection systems and other hood-mounted CORE Protection systems.

All additional PCBCORE controlled packages that are attached to the system must be in "Test Mode." This includes additional fire protection systems, Pollution Control Unit with CORE, and other hood-mounted CORE controlled protection systems.

Please note that the appliances must be started before test mode is entered on any PCBCORE protection package for proper demonstration of this function. If the fire protection system is left in "Test Mode" for more than 15 minutes, the appliances will shut down. This is to prevent cooking operations from occurring while the appliances and ventilation system are not protected.

ATTENTION: All interlocked PCBCORE controlled packages must be placed into "Test Mode" before cleaning the hood, Pollution Control Unit (PCU), or any other interlocked units.

CORE Protection Reset Overview

There are multiple actions required to reset the fire system. First, the duct Firestat must cool below its internal set point, and the remote manual actuation device (push/pull station) must be reset by twisting the button clockwise until it resets. Once both devices are reset, the timer will automatically stop the fire system after its time duration has ended. An alternative method to bypassing the timer is to press the fire system reset button on the face of the electrical control package. This will de-energize the timer and reset the system.

NOTE: The Firestat must be cool, and the remote manual actuation device (push/pull station) must be reset for this button to work.

After a fire, full inspection by a certified professional must be conducted prior to restarting the fire system.

Start-up Procedure – CORE Protection Fire System

1. Perform the self cleaning hood start-up as outlined in the Self Cleaning Hood Manual.
2. The CORE Protection water connection must be a minimum of 3/4" pipe. This must be connected to a water supply line immediately downstream from the building's main shut-off valve or a water fire system. This main valve must be continuously supervised. If other appliances are connected to the CORE water supply line, these appliances must be operated during CORE system testing and taken into consideration when calculating the size of the water line pipe.
3. Refer to **page 63** for Firestat installation overview.
4. Verify remote manual actuation device (push/pull station) is protected with provided clear cover.
5. Verify CORE Protection nozzle caps are easily removed. If nozzle caps stick on the nozzles during a fire system discharge, apply silicone lubricant to the O-ring. Use Danco 88693 lubricant.
6. Verify that all solenoid cables are secured to water lines and not touching the hood.
7. Ensure no supervision faults are reported by the "Fire System Activated" light and that the light flashes one brief flash every 3 seconds, indicating the CORE system is armed and ready.
8. Ensure that the maximum water static pressure on the panel is less than 125 psi.

NOTE: Activating a CORE system will also activate any other CORE, PCU, or HOOD fire system that is connected to the same fire group system. Ensure that all other systems are ready to be tested by placing the system panels in the test mode and ensuring hood filters and drains are in place.

Start-up Procedure – Firestat Activation

1. Place any PCU CORE panel (if present) in "Test Mode."
2. Place Hood CORE Package in Test Mode to prevent Appliances from getting wet.
3. Remove a hood filter directly below the Firestat.
4. Use a portable heat source to apply heat to the duct Firestat. Heat should activate the fire system, and water should begin to spray. The use of a torch or flame is strictly prohibited. Air pressure may exit the appliance drops.
5. Replace the filter and allow the water to spray while reviewing the system.
6. Verify that the water operating pressure is the required minimum psi. Refer to **Table 3 on page 9** through **Table 7 on page 11**. The maximum operating pressure cannot exceed 70 psi.
7. Verify that the surfactant is constantly being injected into the water stream.
8. Verify that all gas and electric cooking appliances have been disabled.
9. Verify that the "Fire System Activated" light illuminates on the control panel and that the audible alarm is sounding.
10. If all of the above is confirmed, reset the fire system by pressing the button on the face of the electrical control package.
11. Place the PCU CORE panel (if present) in "Armed Mode."
12. Place Hood CORE Package in "Armed Mode."

IMPORTANT!

The use of torch or flame to the CORE System Firestats is strictly prohibited.

Start-Up Procedure – Remote Manual Actuation Device Activation

1. Place the PCU CORE panel (if present) in “Test Mode.”
2. Place the Hood CORE Package in “Test Mode.”
3. Lift the clear, protective cover and depress push-button until it latches.
4. Verify that the water operating pressure is the required minimum psi, refer to refer to **Table 3 on page 9** through **Table 7 on page 11**. The maximum operating pressure cannot exceed 70 psi.
5. Verify surfactant is constantly injected into the water stream.
6. Reset the remote manual actuation device (push/pull station). Lift clear, protective cover and rotate push-button clockwise to release push-button.
7. Verify that all gas and electric cooking appliances have been disabled.
8. Verify that the “Fire System Activated” light illuminates on the control panel and that the audible alarm is sounding.
9. If all of the above is confirmed, reset the fire system by pressing the button on the face of the electrical control package.
10. Place the PCU CORE panel (if present) in “Armed Mode.”
11. Place Hood CORE Package in “Armed Mode.”

Start-up Procedure – Battery Back-Up

1. Place the PCU CORE panel (if present) in “Test Mode.”
2. Place the Hood CORE Package in “Test Mode.”
3. Remove **120V AC** to the hood control panel by shutting down the circuit breaker to the panel. After a few seconds, the “Fire System Activated” light will flash a power failure supervision fault code (11 flashes followed by a pause).
4. Lift the clear, protective cover and depress push-button until it latches.
5. Verify that the water operating pressure is the required minimum psi, refer to refer to **Table 3 on page 9** through **Table 7 on page 11**. The maximum operating pressure cannot exceed 70 psi.
6. Verify that the surfactant is constantly being injected into the water stream.
7. Reset the remote manual actuation device (push/pull station). Lift clear, protective cover and rotate push-button clockwise to release push-button.
8. Verify that all gas appliances have been disabled. In the event of power loss to the building, electric appliances will be disabled.
9. If all of the above is confirmed, reset the fire system by pressing the button on the face of the electrical control package.
10. Reset the circuit breaker applying power to the hood panel.
11. Place the PCU CORE panel (if present) in “Armed Mode.”
12. Place the Hood CORE Package in “Armed Mode.” The “Fire System Activated” light will begin flashing one brief flash every 3 seconds, indicating the CORE system is armed and ready.

Start-Up Procedure – Final

1. Verify that the “Fire System Activated” light is flashing one brief flash every 3 seconds, indicating the CORE system is armed and ready.
2. Verify the remote manual actuation device (push/pull station) is reset.
3. Fill the surfactant tank with surfactant.

Reset Procedure – CORE Protection Fire System

1. Fully inspect the system to make sure fire is extinguished.
2. If the fire is out, Firestat should be cool.
3. Reset remote manual actuation device (push/pull station) if tripped.
4. If the Firestat is cool and the remote manual actuation device (push/pull station) has been reset, the CORE system will automatically reset once the fire system timer expires after 15 minutes. Alternatively, the reset button on the face of the electrical control package can be pressed to reset the system.
5. Fill the surfactant tank with surfactant.
6. Inspect or replace the appliance coverage nozzles.
7. Inspect all piping and connections, hood lights, wiring, and hood insulation for integrity.

CORE Total Flood Fire System Overview

In a fire condition, the CORE water solenoid is open, allowing sprinkler water to flow through the manifold. The surfactant is injected continuously throughout the fire system activation. shows the Sprinkler Water side of the wall-mounted manifold that is activated during a “fire” condition. The hot water solenoid remains closed during a fire condition.

Figure 24 - Wall Mount CORE Manifold, Cold Water Flow

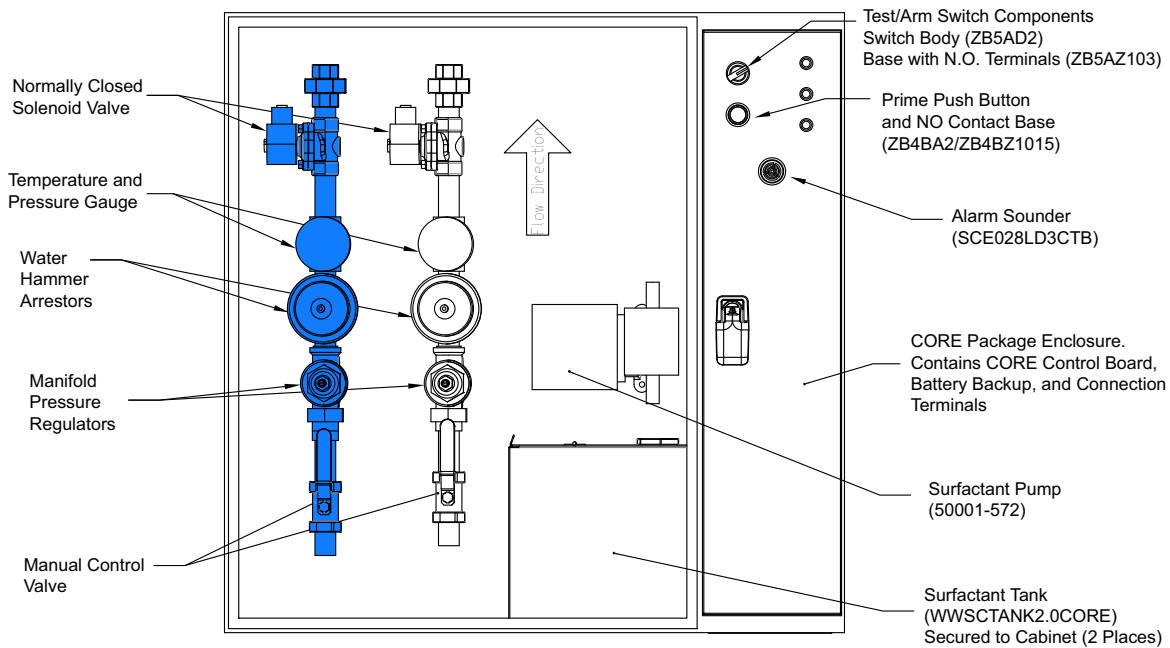

The appliance solenoid on top of the hood opens, allowing water to flow to the duct, plenum, and appliance spray bar.

Figure 25 - Top of Hood Connection for Wall Mount CORE Manifold, Cold Water Flow

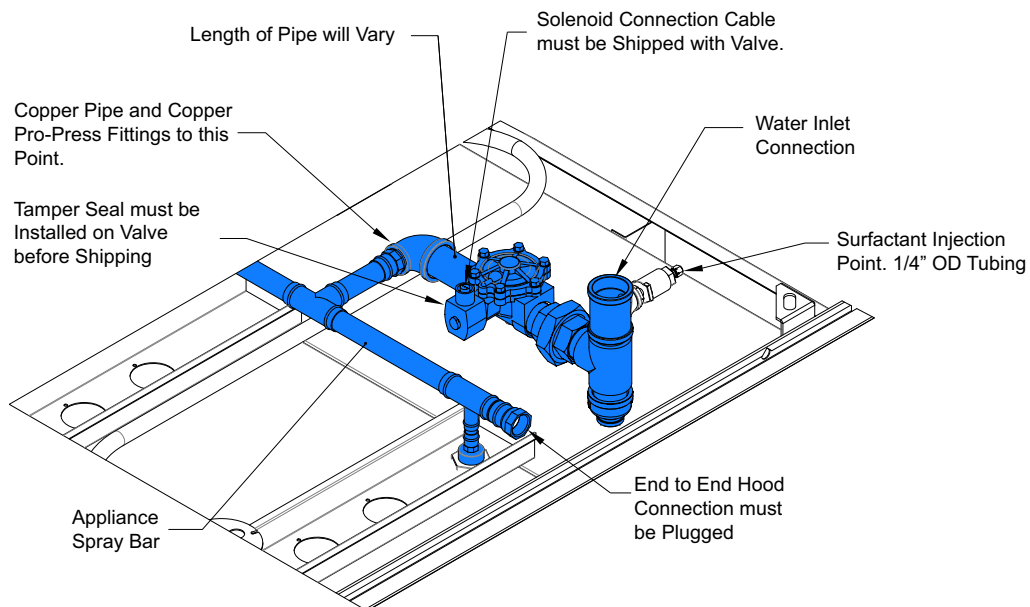

CORE Total Flood Protection Fire System Start-Up

This test method is for hoods with CORE Total Flood Protection. For CORE Protection with separate appliance coverage, refer to “**CORE Protection Test Mode Overview**” on page 34.

Special Tools:

- AC Voltage Meter
- Standard Hand Tools
- Hand-held Heat Source
- Surfactant - Part Number WWDETER for 4 Gallons, WWDETER-1G for 1 Gallon
- Silicone Lubricant - Danco 88693
- High-Temperature Wire for Supervised Loop on Hood:
 - Type MG, White Part Number 441601C6.FE9
 - Type MG, Black Part Number 441601C6.FE0
 - Supervised Loop Wire for Off Hood Connections - Belden Part Number 6320UL or similar

NOTE: The supervised loop must be run through metallic conduit. Do not run wiring with high voltage wires.

Jobsite Qualifications – Pre-installation CORE Protection Fire System

1. Verify the source for the CORE water supply (domestic or sprinkler), and determine the pressure drop from the connection at the source to the connection at the CORE manifold inlet.
2. Verify the proper amount of water pressure and flow-rate is available for CORE Protection. If the operating and static pressures exceed the maximum listing, identify and size a pressure reducing valve.
3. Verify if a shut-off valve will be required on the CORE supply line.
4. Verify the manifold location, and if a backflow preventer is required.
5. Verify the availability of a grease drain and grease trap size.
6. Verify there is access to the top of the hood.
7. Verify a network connection for CASLink.
8. Verify duct location.

Start-up Checklists

Self Cleaning Hood

Action	Completed (Yes/No)	Result
Check All Nozzles are Tight		
Open all Valves to Hood		
Fill Surfactant Tank		
Prime Surfactant Pump		
Set All Timers		
Check Fan Operation		
Operate Wash Cycle		
Verify Surfactant Pump Operation		
Verify Operating Hot Water Pressure		
Verify Max Water Static Pressure (125 PSI)		
Verify Min Hot Water Temperature (140°F)		
Check For Leaks in Manifold		
Check For Leaks through Filters		
Verify that Water is Draining Properly		

CORE Protection System

Action	Completed (Yes/No)	Result
Self Cleaning Startup Complete		
Main Water line 3/4" or Larger		
Main Water Line from Supervised Supply		
"Fire System Activated" light is illuminated.		
Verify there are no fault lights/messages active.		
Test Firestat System Activation		
Test Remote Manual Actuation Device (push/pull station) System Activation		
Verify Manual Actuation Device Cover Installed		
Verify Water Pressure		
Verify Max Water Static Pressure (125 PSI)		
Verify Constant Surfactant Injection		
Verify Appliance Solenoid Activates		
All Gas and Electric Appliances Shut Down		
Audible Alarm Sounds		
Verify Reset Button Works Correctly		
System Activates on Battery Backup		
Verify Surfactant Tank is Full		
Verify Appliance System Test Switch is in Armed Mode		
Reset Remote Manual Actuation Device (push/pull station)		

CORE Protection System Reset

Action	Completed (Yes/No)	Result
Ensure Fire is Extinguished		
Reset Remote Manual Actuation Device (if pushed)		
Press The CORE Reset Button		
Verify Surfactant Tank is Full		
Verify Appliance System Test Switch is in Armed Mode		
Inspect or Replace All Appliance Nozzles After a Fire		
Inspect All Piping Connections After a Fire		
Inspect All Hood Lights After a Fire		
Inspect All Wiring and Hood Insulation After a Fire		

Component Description

The following section lists the major controls and components used in the self cleaning hood and the CORE Protection fire system.

Self Cleaning Spray Bar/CORE Duct and Plenum Coverage

The self cleaning hood contains a spray bar (**Figure 26 on page 42**) that extends the entire length of the hood immediately behind the filters in the hood. The bar is 3/4" brass fittings with nozzles that spray directly toward the back of the hood. The same spray bar is used in hot water wash, cold water mist, and CORE Protection fire systems. Water enters the spray bar through a 3/4" quick-seal. The other end of the spray bar is plugged. If hoods are installed back-to-back or end-to-end, the plugged end of the spray bar can be unplugged and connected to the next spray bar.

1. All pipe will be Copper. Pipe fittings will be Brass/Copper Pro-Press.
2. Sections of pipe and tees can be pre-assembled for use. Refer to **Table 13** and **Table 14** for details.
3. Ends will be made using a Street elbow inside a quick-seal.
4. The variable length section of pipe will be used to complete the spray assembly.
5. On hoods 6' and longer, a tee will be installed at the center of the spray bar for support. This will be a 3/4" x 3/4" NPT x 3/4" Pro-Press Tee with a plugged quick-seal. If there is interference with the riser, move supports to both sides of riser. On hoods 12' and longer, two (2) tees will be installed spaced evenly to support the spray bar.
6. Riser plumbing will be 1/4" NPT Brass. The placement of the elbow is dependent on the riser location. The nozzle needs be centered, both vertically and horizontally, within the riser. Riser nozzle must follow **Table 14**.
7. When riser nozzle is located directly under center of riser on spray bar, main elbow must point upwards.
8. Omit plenum nozzle on riser nozzle branch.

Table 13 - Pro-Press Parts for Plenum Spray Bar

Item	Description	Part Number	A/X
1	3/4" x 3/4" NPT Male Pro-Press Adapter	79230	A0028284
2	3/4" x 1/4" NPT x 3/4" Pro-Press Tee	79585	A0028285
Not Shown	3/4" x 3/4" NPT x 3/4" Pro-Press Tee	79595	A0028286

Table 14 - Nozzles for Hot Water Wash (W1)

Description	Part Number (P/N)	Previous P/N	A/X	Flow Rate
Nozzles for Hot Water Wash (W1)				
CORE Plenum Male Riser Nozzle	CPL-M	1/4TT+TG-4.3W	A0025166	0.70 GPM @ 30 PSI
CORE Plenum Male Spray Bar Nozzle	CPL-M	1/4TT+TG-4.3W	A0025166	0.70 GPM @ 30 PSI
Nozzles for CORE Protection (WC)				
CORE Riser Male Nozzle	CR-M	1/4TT+TP1530+CP1325	A0002784	0.70 GPM @ 30 PSI
CORE Plenum Male Spray Bar Nozzle	CPL-M	1/4TT+TG-4.3W	A0025166	0.70 GPM @ 30 PSI

NOTE: 100" perimeter per riser nozzle for CORE.

Figure 26 - Spray Bar Details

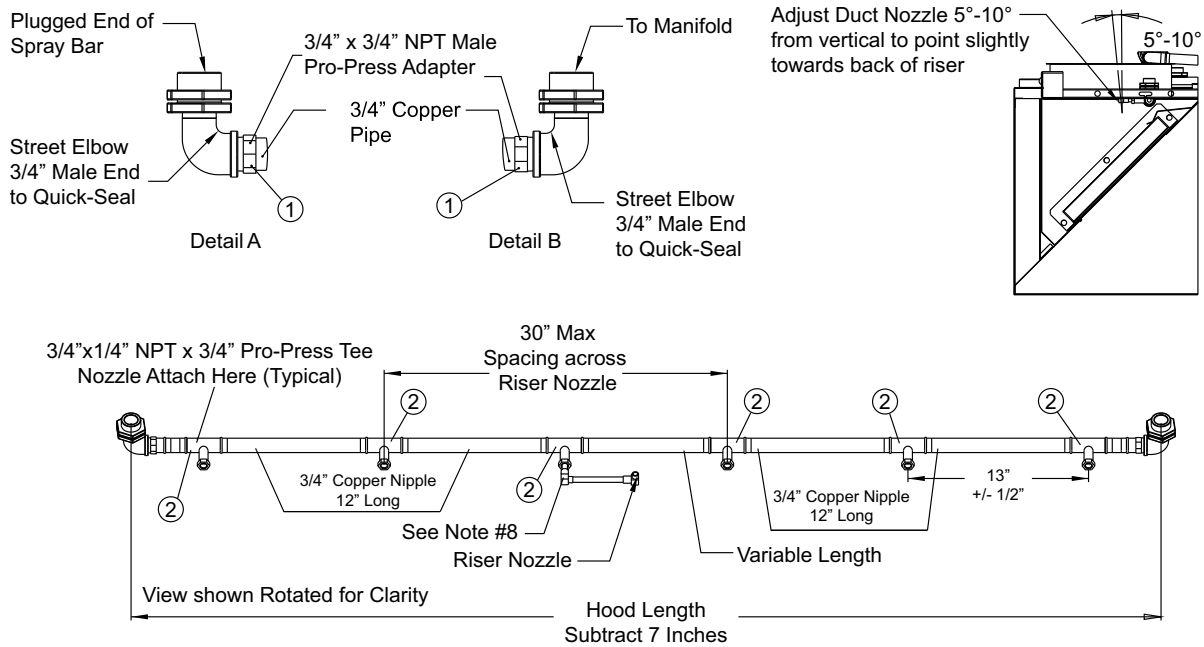

Water Manifolds

The self cleaning with CORE Protection fire system has one hot water connection and one supervised water source connection for CORE.

Figure 27 - Hood Mounted Utility Cabinet

Notes:

1. All manifold fittings and pipe will be Brass. Drain components are Chrome-plated 17 ga. Brass
2. All wiring must be located inside liquid tight conduit

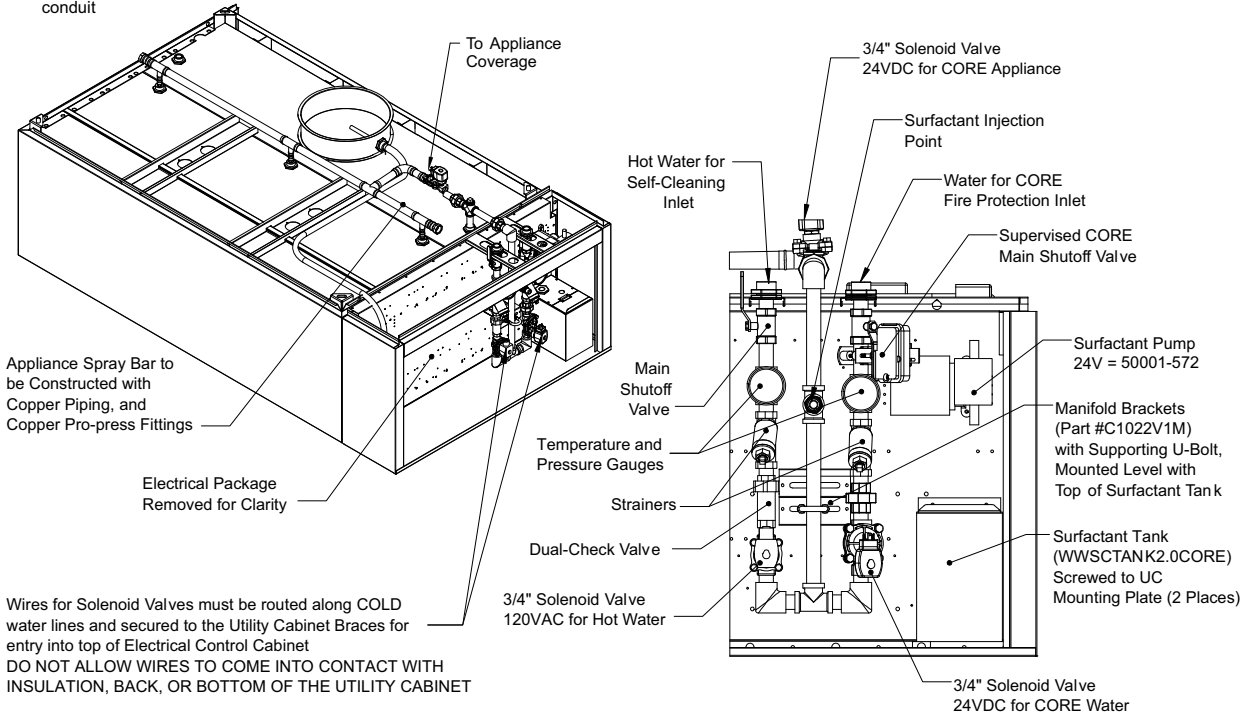

3/4" Self Cleaning with CORE Total Flood Protection Manifold

1. All fittings and pipe will be brass. Drain components are chrome-plated 17-gauge brass.
2. Length and width of manifold must match measurements listed in **Figure 28**.
3. All pipe nipples are close, unless otherwise noted.
4. For 30" tall hoods, plumbing must be lengthened in three places by 5", noted with an *.
5. Valves and gauges can be rotated for best fit in cabinet. Gauge faces must be visible.
6. Optional slow-close solenoid part # SC8221G005-120VAC may be used as an alternative.
7. Optional slow-close solenoid part # SC8221G005-24VDC may be used as an alternative.
8. Slow-close solenoids cannot be used as an appliance solenoid in this location.

NOTE: Pipe dope must be used to seal threads. DO NOT USE TEFLON TAPE.

Figure 28 - 3/4" Self Cleaning CORE Total Flood Protection Details

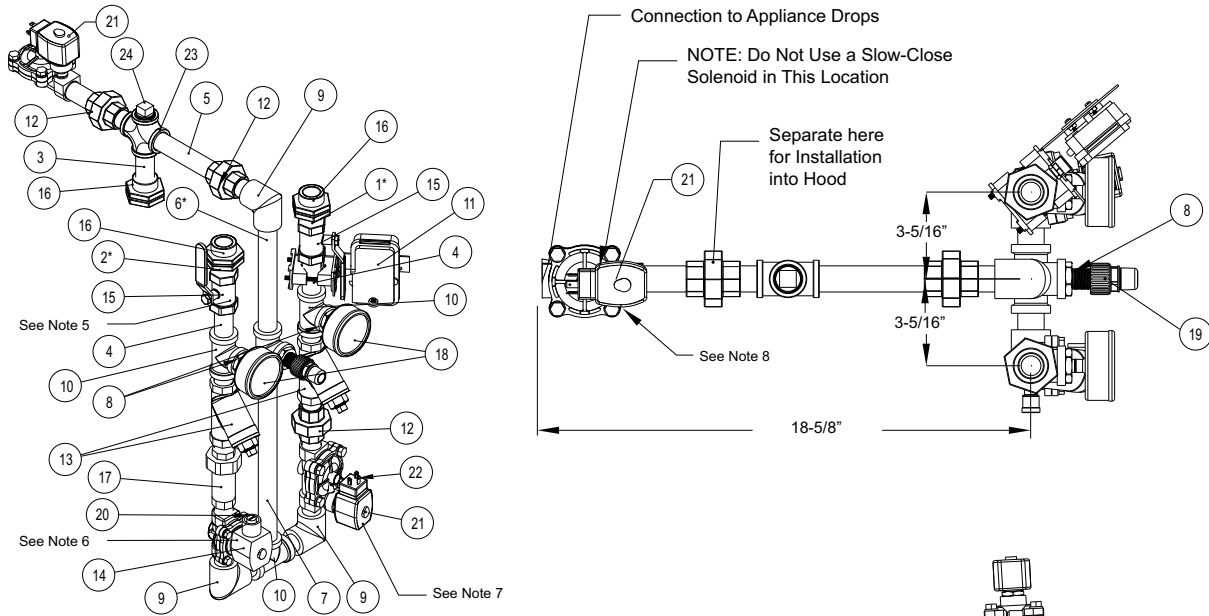

Manifold Parts					
#	Description	Part #		Macola #	Quantity Used
		24" Tall Hoods	30" Tall Hoods		
1	3/4" Close Brass Nipple	4568K191	4568K191	4568K191	12
2	3/4" x 2" Brass Nipple	4568K192	4568K375	VARIES	1
3	3/4" x 2-1/2" Brass Nipple	4568K193	4568K193	4568K193	1
4	3/4" x 3" Brass Nipple	4568K194	4568K194	4568K194	2
5	3/4" x 5" Brass Nipple	4568K198	4568K198	4568K198	1
6	3/4" x 7" Brass Nipple	4568K375	4568K215	VARIES	1
7	3/4" x 12" Brass Nipple	4568K215	4568K215	4568K215	1
8	3/4" x 1/4" Adapter	AQ2564	AQ2564	AQ2564	3
9	3/4" Brass Elbow	4429K164	4429K164	4429K164	3
10	3/4" Brass Tee	BRF205IG	A0007789	A0007789	5
11	Potter Ball Valve Monitoring Switch	PL-RVBS	A0024584	A0024584	1
12	3/4" Brass Union	4429K215	4429K215	4429K215	3
13	3/4" Brass Wye Strainer	43935K24	43935K24	43935K24	2
14	3/4" Brass Solenoid Valve, 120V	SC8210G009 120/60, 110/50	AQ3105	AQ3105	1
15	3/4" Manual Ball Valve	47865K24	47865K24	47865K24	2
16	3/4" Quick Seal	172	372	372	3
17	3/4" Backflow Preventer	LF7RU22	A0025518	A0025518	1
18	Temperature and Pressure gauge	DPTG3-2-1/2	AQ2516	AQ2516	2
19	1/4" Check Valve	47715K21	47715K21	47715K21	1
20	Solenoid Connection Cable 120V	5J684-551-US0A	AQ3602	AQ3602	1
21	3/4" Brass Solenoid Valve, 24V	SC8210G003-24DC	AQ3205	AQ3205	2
22	Solenoid Connection Cable, 24V	5J684-251-US0A	AQ3603	AQ3603	2
23	3/4" Cross	4429K354	A0032043	A0032043	1
24	3/4" Brass Plug	4429K315	A0021678	A0021678	1

All Nipples are Close, Unless Noted Otherwise

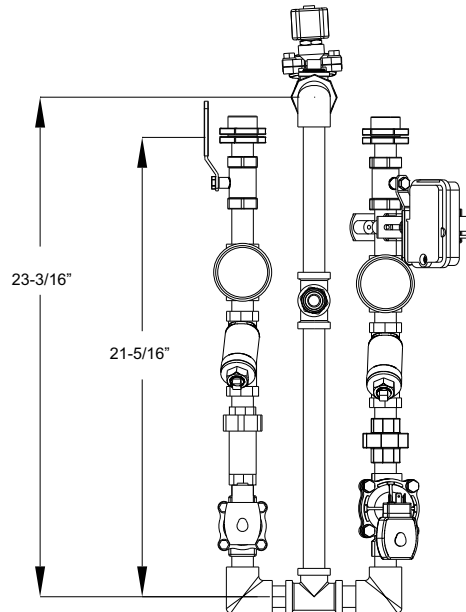

1" Self Cleaning with CORE Total Flood Protection Manifold

1. All fittings and pipe will be brass. Drain components are chrome-plated 17-gauge brass.
2. Length and width of manifold must match measurements listed in **Figure 29**.
3. All pipe nipples are close, unless otherwise noted.
4. For 30" tall hoods, plumbing must be lengthened in three places by 3", noted with an *.
5. Valves and gauges can be rotated for best fit in cabinet. Gauge faces must be visible.
6. Optional slow-close solenoid part # SC8221G007-120VAC may be used as an alternative.
7. Optional slow-close solenoid part # SC8221G007-24VDC may be used as an alternative.
8. Slow-close solenoids cannot be used as an appliance solenoid in this location.

NOTE: Pipe dope must be used to seal threads. DO NOT USE TEFLON TAPE.

Figure 29 - 1" Self Cleaning CORE Total Flood Protection Details

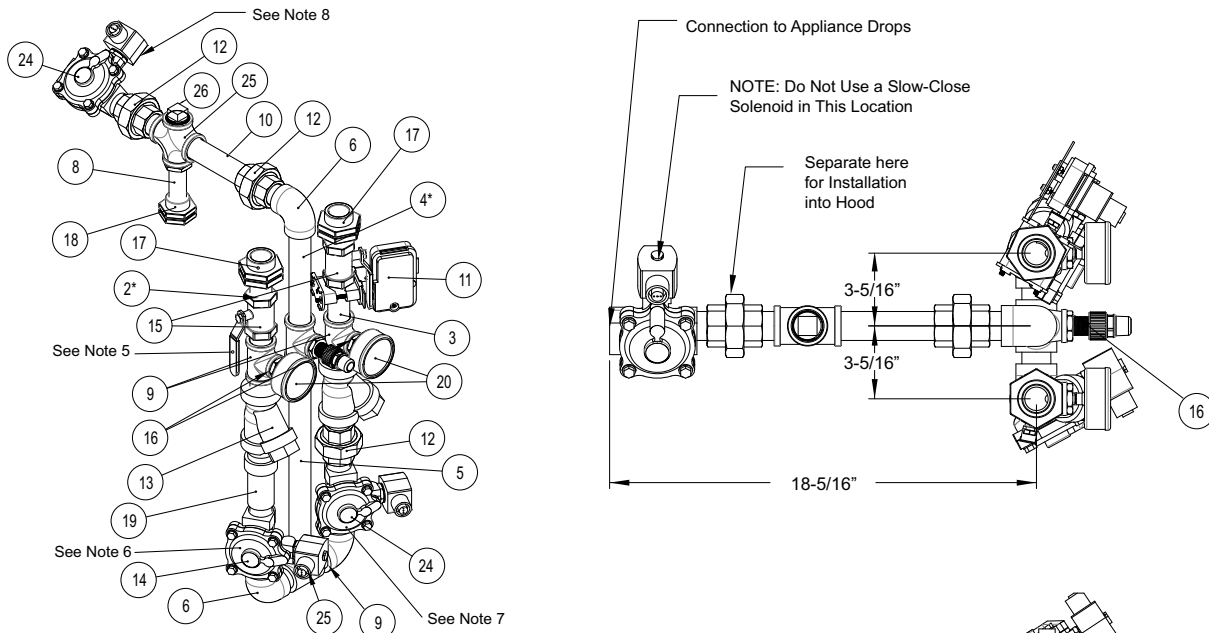

#	Description	Part #		Macola #	Quantity Used
		24" Tall Hoods	30" Tall Hoods		
1	1" Close Brass Nipple	AQ2522	AQ2522	AQ2522	13
2	1" Close Brass Nipple	AQ2522	4568K228	VARIABLE	2
3	1" x 3" Brass Nipple	4568K224	4568K228	4568K224	2
4	1" x 7" Brass Nipple	4568K367	4568K234	VARIABLE	1
5	1" x 14" Brass Nipple	4568K751	4568K751	4568K751	1
6	1" Brass Elbow	4429K165	A0014022	A0014022	3
7	1" Brass Tee	AQ2578	AQ2578	AQ2578	1
8	3/4" x 2-1/2" Brass Nipple	4568K193	4568K193	4568K193	1
9	1" x 3/4" x 1" Brass Tee	4429K238	A0024232	A0024232	4
10	1" x 5" Brass Nipple	4568K228	4568K228	4568K228	1
11	Potter Ball Valve Monitoring Switch	PL-RVBS			1
12	1" Brass Union	BR106A	A0007774	A0007774	3
13	1" Brass Wye Strainer	43935K25	A0026974	A0026974	2
14	1" Brass Solenoid Valve, 120V	SC8210G004-120VAC	A0017119	A0017119	1
15	1" Manual Ball Valve	MBV-1.0NN (EC)	10406	10406	2
16	3/4" To 1/4" Brass Bushing	AQ2564	AQ2564	AQ2564	3
17	1" Quick Seal	213	A0003378	A0003378	2
18	3/4" Quick Seal	172	372	372	1
19	1" Backflow Preventer	LF7RU2-2	A0026338	A0026338	1
20	Temperature and Pressure gauge	DPTG3-2-1/2	AQ2516	AQ2516	2
21	Surfactant Injection Point	AQ2542	A0007013	A0007013	1
22	1" Brass Solenoid Valve, 24V	SC8210G004-24DC	A0019960	A0019960	2
23	Solenoid Connection Cable 120V	5J684-551-US0A	AQ3602	AQ3602	1
24	Solenoid Connection Cable 24V	5J684-251-US0A	AQ3603	AQ3603	2
25	1" Cross	4429K355	A0034109	A0034109	1
26	1" Brass Plug	4429K287	A0028378	A0028378	1

All Nipples are Close, Unless Noted Otherwise

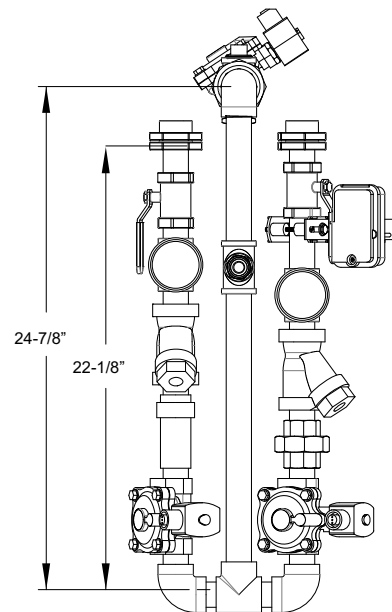

1-1/2" Self Cleaning with CORE Total Flood Protection Manifold

1. All fittings and pipe will be brass. Drain components are chrome-plated 17-gauge brass.
2. Length and width of manifold must match measurements listed in **Figure 30**.
3. All pipe nipples are close, unless otherwise noted.
4. Valves and gauges can be rotated for best fit in cabinet. Gauge faces must be visible.
5. Optional slow-close solenoid part # SC8221G011-120VAC may be used as an alternative.
6. Optional slow-close solenoid part # SC8221G011-24VDC may be used as an alternative.
7. Slow-close solenoids cannot be used as an appliance solenoid in this location.

NOTE: Pipe dope must be used to seal threads. DO NOT USE TEFLON TAPE.

Figure 30 - 1-1/2" Self Cleaning CORE Total Flood Protection Details

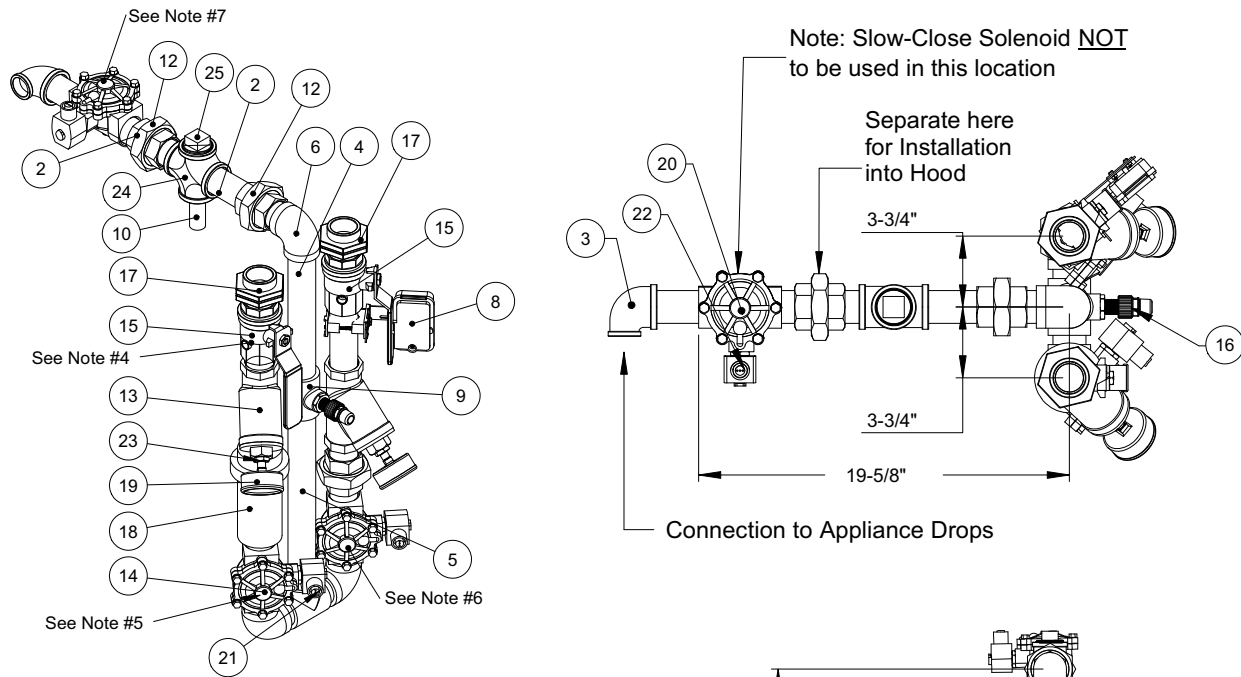

Manifold Parts				
#	Description	Part #	Macola #	Quantity Used
1	1-1/2" Close Brass Nipple	AQ2520	A0007003	14
2	1-1/2" x 3-3/4" Brass Nipple	4568K266	4568K266	2
3	1-1/2" x 1" Brass Reducing Elbow	4429K175	4429K175	1
4	1-1/2" x 10" Brass Nipple	4568K274	4568K274	1
5	1-1/2" x 14" Brass Nipple	4568K771	4568K771	1
6	1-1/2" Brass Elbow	AQ2502	A0006996	3
7	1-1/2" Brass Tee	4429K257	A0021582	1
8	Potter Ball Valve Monitoring Switch	PL-RVBS	-	1
9	1-1/2" x 3/4" x 1-1/2" Brass Tee	4429K341	A0024232	2
10	3/4" x 3" Brass Nipple	4568K194	4568K194	1
11	3/4" Quick Seal	172	372	1
12	1-1/2" Brass Union	1BR125UJ	A0023262	3
13	1-1/2" Brass Wye Strainer	43935K27	43935K27	2
14	1-1/2" Brass Solenoid Valve, 120V	SC8210G022-120VAC	A0017120	1
15	1-1/2" Gauge Port Ball Valve	4085T25	A0027373	2
16	Surfactant Injection Point	AQ2542	A0007013	1
17	1-1/2" Quick Seal	HMU375	376	2
18	1-1/2" Backflow Preventer	LF07S	A0027372	1
19	Temperature and Pressure Gauge	DPTG3-2-1/2	AQ2516	2
20	1-1/2" Brass Solenoid Valve, 24V	SC8210G022-24DC	A0019960	2
21	Solenoid Connection Cable 120V	5J684-551-US0A	AQ3602	1
22	Solenoid Connection Cable 24V	5J684-251-US0A	AQ3603	2
23	1/2" x 1/4" NPT Bushing	4429K422	4429K422	2
24	1-1/2" Cross	4429K356	A0015569	1
25	1-1/2" Brass Plug	4429K318	A0024254	1

All Nipples are Close, Unless Noted Otherwise

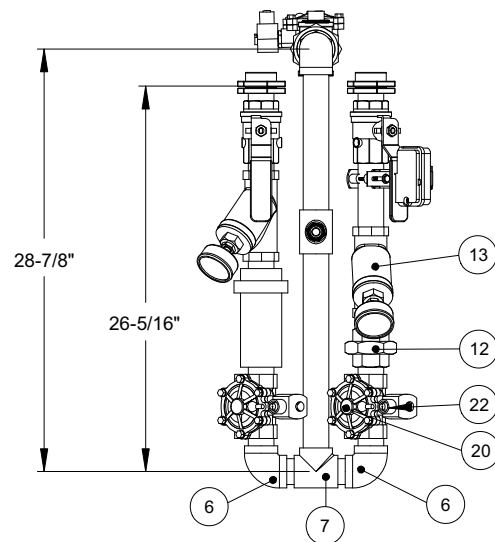

3/4" Self Cleaning with CORE Wall Mounted Utility Cabinet Manifold

1. All fittings and pipe will be brass. Drain components are chrome-plated 17-gauge brass.
2. Length and width of manifold must match measurements listed in **Figure 31**.
3. All pipe nipples are close, unless otherwise noted.
4. For 30" tall hoods, plumbing must be lengthened in three places by 5", noted with an *.
5. Valves and gauges can be rotated for best fit in cabinet. Gauge faces must be visible.
6. Optional slow-close solenoid part # SC8221G005-120VAC may be used as an alternative.
7. Optional slow-close solenoid part # SC8221G005-24VDC may be used as an alternative.

NOTE: Pipe dope must be used to seal threads. DO NOT USE TEFLON TAPE.

Figure 31 - 3/4" Self Cleaning with CORE WM UC Manifold Detail

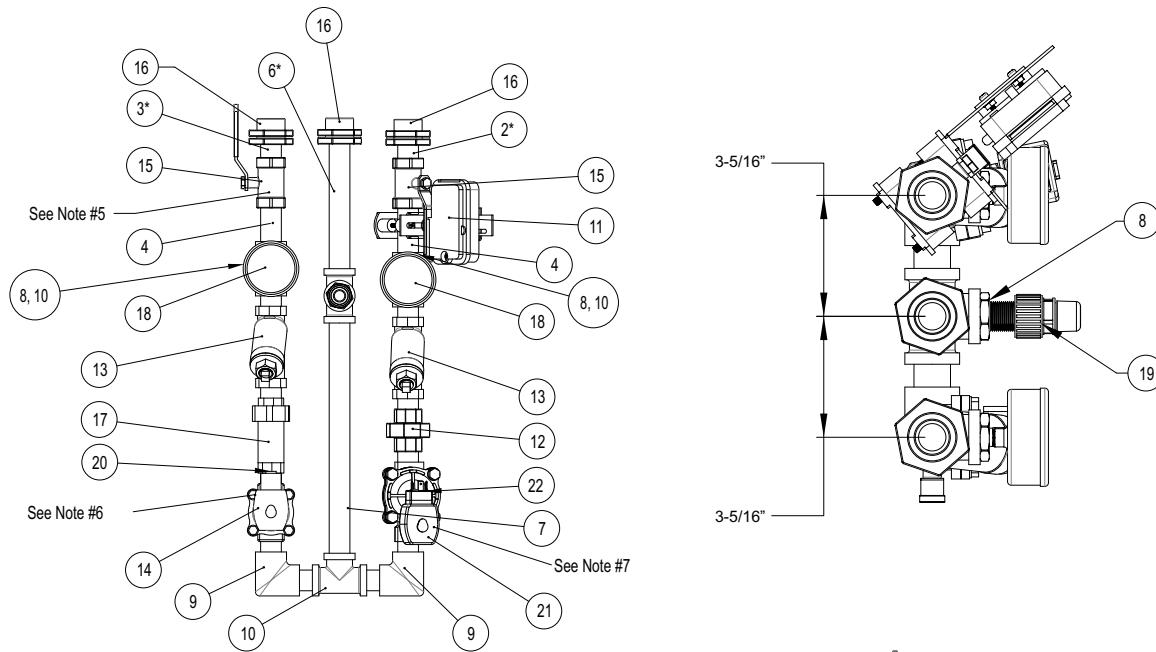

Manifold Parts					
#	Description	Part #		Macola #	Quantity Used
		24" Tall Hoods	30" Tall Hoods		
1	3/4" Close Brass Nipple	4568K191		4568K191	12
2	3/4" x 2" Brass Nipple	4568K192	4568K375	VARIABLES	1
3	3/4" x 2-1/2" Brass Nipple	4568K193		4568K193	1
4	3/4" x 3" Brass Nipple	4568K194		4568K194	2
5	3/4" x 5" Brass Nipple	4568K198		4568K198	1
6	3/4" x 7" Brass Nipple	4568K375	4568K215	VARIABLES	1
7	3/4" x 12" Brass Nipple	4568K215		4568K215	1
8	3/4" x 1/4" Adapter	AQ2564		AQ2564	3
9	3/4" Brass Elbow	4429K164		4429K164	3
10	3/4" Brass Tee	BRF205IG		A0007789	5
11	Potter Ball Valve Monitoring Switch	PL-RVBS		A0024584	1
12	3/4" Brass Union	4429K215		4429K215	3
13	3/4" Brass Wye Strainer	4393K24		4393K24	2
14	3/4" Brass Solenoid Valve, 120V	SC8210G009 120/60, 110/50		AQ3105	1
15	3/4" Manual Ball Valve	47865K24		47865K24	2
16	3/4" Quick Seal	172		372	3
17	3/4" Backflow Preventer	LF7RU22		A0025518	1
18	Temperature and Pressure gauge	DPTG3-2-1/2		AQ2516	2
19	1/4" Check Valve	47715K21		47715K21	1
20	Solenoid Connection Cable 120V	5J684-551-US0A		AQ3602	1
21	3/4" Brass Solenoid Valve, 24V	SC8210G003-24DC		AQ3205	2
22	Solenoid Connection Cable, 24V	5J684-251-US0A		AQ3603	2

All Nipples are Close, Unless Noted Otherwise

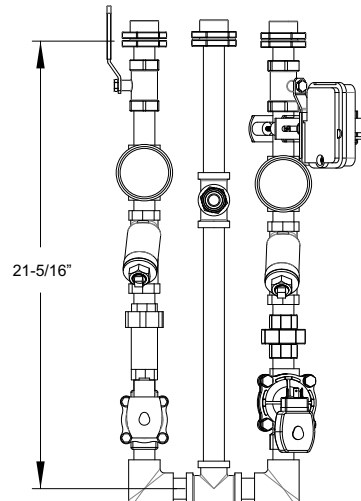

1" Self Cleaning with CORE Wall Mounted Utility Cabinet Manifold

1. All fittings and pipe will be brass. Drain components are chrome-plated 17-gauge brass.
2. Length and width of manifold must match measurements listed in **Figure 32**.
3. All pipe nipples are close, unless otherwise noted.
4. For 30" tall hoods, plumbing must be lengthened in three places by 3", noted with an *.
5. Valves and gauges can be rotated for best fit in cabinet. Gauge faces must be visible.
6. Optional slow-close solenoid part # SC8221G007-120VAC may be used as an alternative.
7. Optional slow-close solenoid part # SC8221G007-24VDC may be used as an alternative.

NOTE: Pipe dope must be used to seal threads. DO NOT USE TEFLON TAPE.

Figure 32 - 1" Self Cleaning with CORE WM UC Manifold Detail

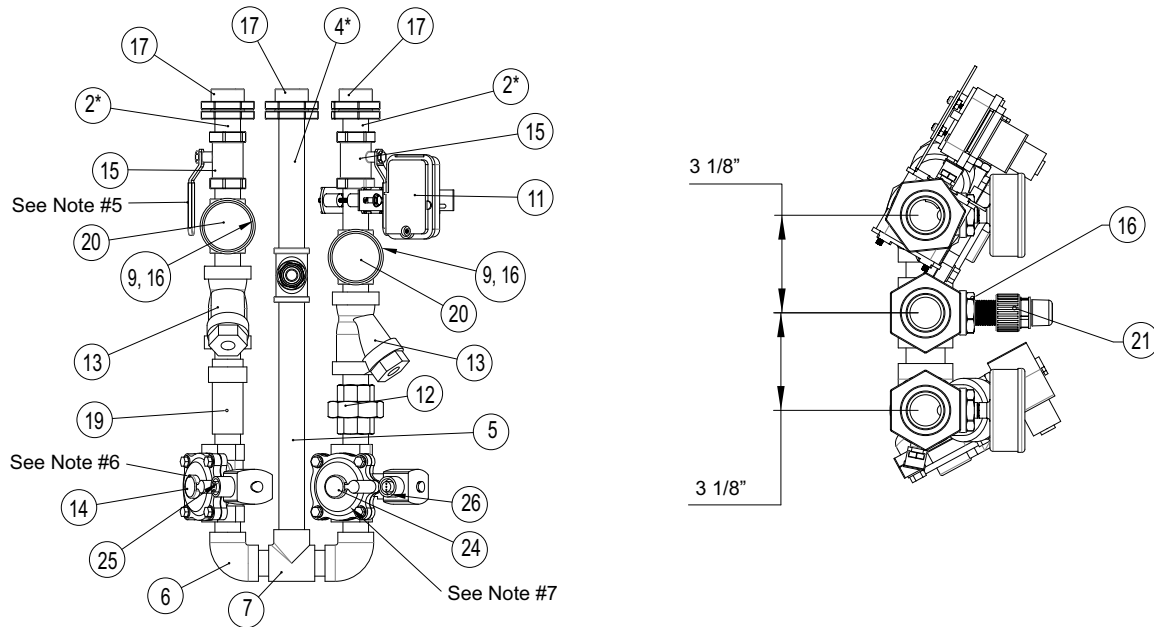

#	Description	Part #		Macola #	Quantity Used
		24" Tall Hoods	30" Tall Hoods		
1	1" Close Brass Nipple	AQ2522		AQ2522	13
2	1" Close Brass Nipple	AQ2522	4568K228	VARIES	2
3	1" x 3" Brass Nipple	4568K224	4568K228	4568K224	2
4	1" x 7" Brass Nipple	4568K367	4568K234	VARIES	1
5	1" x 14" Brass Nipple	4568K751		4568K751	1
6	1" Brass Elbow	4429K165		A0014022	3
7	1" Brass Tee	AQ2578		AQ2578	1
8	3/4" x 2-1/2" Brass Nipple	4568K193		4568K193	1
9	1" x 3/4" x 1" Brass Tee	4429K238		A0024232	4
10	1" x 5" Brass Nipple	4568K228		4568K228	1
11	Potter Ball Valve Monitoring Switch	PL-RVBS			1
12	1" Brass Union	BR106A		A0007774	3
13	1" Brass Wye Strainer	43935K25		A0026974	2
14	1" Brass Solenoid Valve, 120V	SC8210G004-120VAC		A0017119	1
15	1" Manual Ball Valve	MBV-1.0NN (EC)		10406	2
16	3/4" To 1/4" Brass Bushing	AQ2564		AQ2564	3
17	1" Quick Seal	213		A0003378	2
18	3/4" Quick Seal	172		372	1
19	1" Backflow Preventer	LF7RU2-2		A0026338	1
20	Temperature and Pressure gauge	DPTG3-2-1/2		AQ2516	2
21	Surfactant Injection Point	AQ2542		A0007013	1
22	1" Brass Solenoid Valve, 24V	SC8210G004-24DC		A0019960	2
23	Solenoid Connection Cable 120V	5J684-551-US0A		AQ3602	1
24	Solenoid Connection Cable 24V	5J684-251-US0A		AQ3603	2

All Nipples are Close, Unless Noted Otherwise

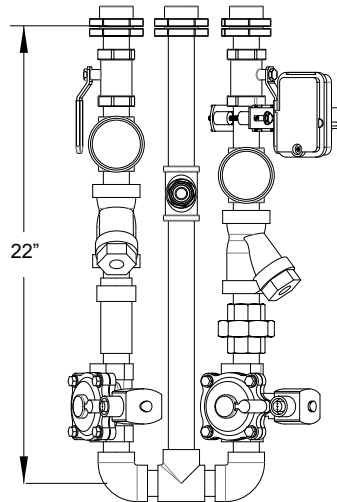

1-1/2" Self Cleaning with CORE Wall Mounted Utility Cabinet Manifold

1. All fittings and pipe will be brass. Drain components are chrome-plated 17-gauge brass.
2. Length and width of manifold must match measurements listed in **Figure 33**.
3. All pipe nipples are close, unless otherwise noted.
4. Valves and gauges can be rotated for best fit in cabinet. Gauge faces must be visible.
5. Optional slow-close solenoid part # SC8221G011-120VAC may be used as an alternative.
6. Optional slow-close solenoid part # SC8221G011-24VDC may be used as an alternative.
7. Slow-close solenoids cannot be used as an appliance solenoid in this location.

NOTE: Pipe dope must be used to seal threads. DO NOT USE TEFLON TAPE.

Figure 33 - 1-1/2" Self Cleaning with CORE WM UC Manifold

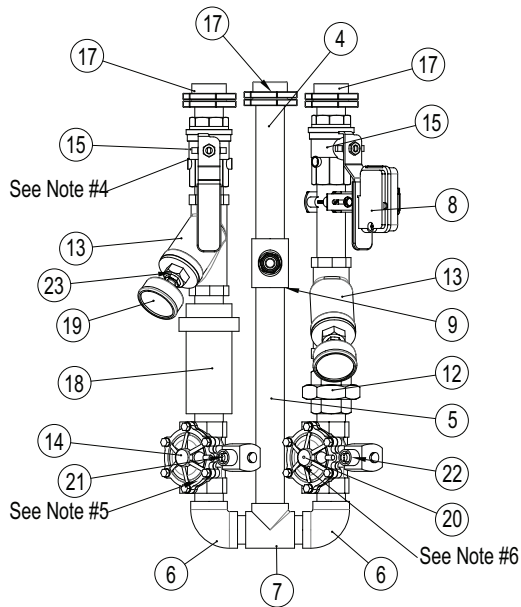

Manifold Parts				
#	Description	Part #	Macola #	Quantity Used
1	1-1/2" Close Brass Nipple	AQ2520	A0007003	14
2	1-1/2" x 3-3/4" Brass Nipple	4568K266	4568K266	2
3	1-1/2" x 1" Brass Reducing Elbow	4429K175	4429K175	1
4	1-1/2" x 10" Brass Nipple	4568K274	4568K274	1
5	1-1/2" x 14" Brass Nipple	4568K771	4568K771	1
6	1-1/2" Brass Elbow	AQ2502	A0006996	3
7	1-1/2" Brass Tee	4429K257	A0021582	1
8	Potter Ball Valve Monitoring Switch	PL-RVBS	-	1
9	1-1/2" x 3/4" x 1-1/2" Brass Tee	4429K341	A0024232	2
10	3/4" x 3" Brass Nipple	4568K194	4568K194	1
11	3/4" Quick Seal	172	372	1
12	1-1/2" Brass Union	1BR125UJ	A0023262	3
13	1-1/2" Brass Wye Strainer	43935K27	43935K27	2
14	1-1/2" Brass Solenoid Valve, 120V	SC8210G022-120VAC	A0017120	1
15	1-1/2" Gauge Port Ball Valve	4085T25	A0027373	2
16	Surfactant Injection Point	AQ2542	A0007013	1
17	1-1/2" Quick Seal	HMU375	376	2
18	1-1/2" Backflow Preventer	LF07S	A0027372	1
19	Temperature and Pressure Gauge	DPTG3-2-1/2	AQ2516	2
20	1-1/2" Brass Solenoid Valve, 24V	SC8210G022-24VDC	A0019960	2
21	Solenoid Connection Cable 120V	5J684-551-US0A	AQ3602	1
22	Solenoid Connection Cable 24V	5J684-251-US0A	AQ3603	2
23	1/2" x 1/4" NPT Bushing	4429K422	4429K422	2

All Nipples are Close, Unless Noted Otherwise

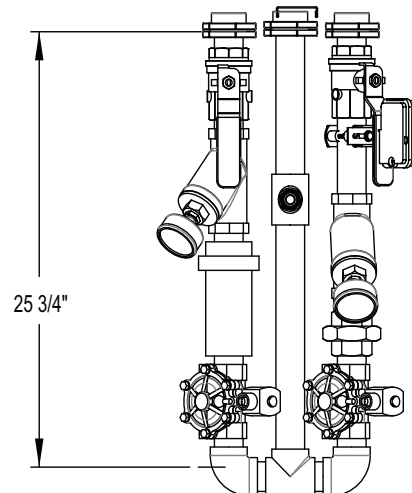
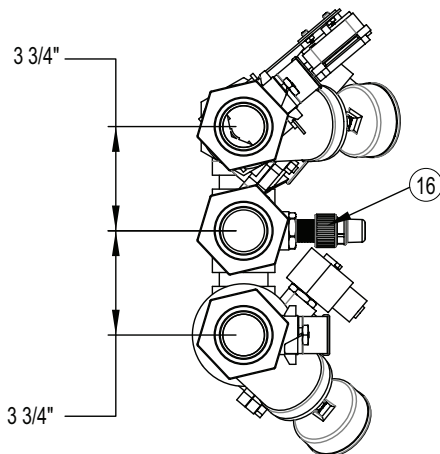

3/4" Duct & Plenum Protection Manifold

1. All fittings and pipe will be brass. Drain components are chrome-plated 17-gauge brass.
2. Length and width of manifold must match measurements listed in **Figure 34**.
3. All pipe nipples are close, unless otherwise noted.
4. For 30" tall hoods, plumbing must be lengthened in three places by 5", noted with an *.
5. Valves and gauges can be rotated for best fit in cabinet. Gauge faces must be visible.
6. Optional slow-close solenoid part # SC8221G005-120VAC may be used as an alternative.
7. Optional slow-close solenoid part # SC8221G005-24VDC may be used as an alternative.

Figure 34 - 3/4" CORE Duct and Plenum Protection Manifold Detail

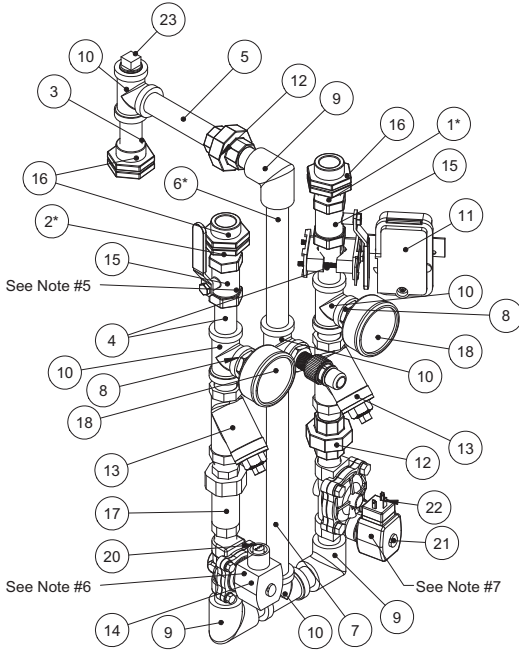

Manifold Parts				
#	Description	Part #		Quantity Used
		24" Tall Hoods	30" Tall Hoods	
1	3/4" Close Brass Nipple	4568K191	4568K191	12
2	3/4" x 2" Brass Nipple	4568K192	4568K375	1
3	3/4" x 2-1/2" Brass Nipple	4568K193	4568K193	1
4	3/4" x 3" Brass Nipple	4568K194	4568K194	2
5	3/4" x 5" Brass Nipple	4568K196	4568K196	1
6	3/4" x 7" Brass Nipple	4568K375	4568K215	1
7	3/4" x 12" Brass Nipple	4568K215	4568K215	1
8	3/4" x 1/4" Adapter	AQ2564		3
9	3/4" Brass Elbow	4429K164	4429K164	3
10	3/4" Brass Tee	4429K254	4429K254	5
11	Potter Ball Valve Monitoring Switch	PL_RVBS		1
12	3/4" Brass Union	4429K215	4429K215	3
13	3/4" Brass Wye Strainer	4393K24	4393K24	2
14	3/4" Brass Solenoid Valve, 120V	SC8210G009 120/60, 110/50	AQ3105	1
15	3/4" Manual Ball Valve	4786SK24	4786SK24	2
16	3/4" Quick Seal	172	372	3
17	3/4" Backflow Preventer	LF77RU22	A0025518	1
18	Temperature and Pressure gauge	DPTG3-2-1/2	AQ2516	2
19	Surfactant Injection Point	AQ2542	A0007013	1
20	Solenoid Connection Cable, 120V	5J884-551-US0A	AQ3602	1
21	3/4" Brass Solenoid Valve, 24V	SC8210G003-24DC	AQ3205	1
22	Solenoid Connection Cable, 24V	5J884-251-US0A	AQ3603	1
23	3/4" Brass Plug	4429K315	A0021678	1

All Nipples are Close, Unless Noted Otherwise

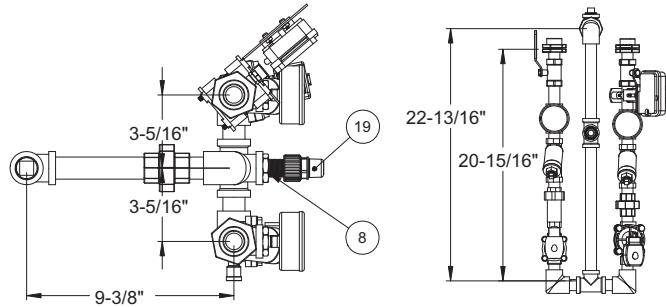

1" CORE Duct and Plenum Protection Manifold

1. All fittings and pipe will be brass. Drain components are chrome-plated 17-gauge brass.
2. Length and width of manifold must match measurements listed in **Figure 35**.
3. All pipe nipples are close, unless otherwise noted.
4. For 30" tall hoods, plumbing must be lengthened in three places by 3", noted with an *.
5. Valves and gauges can be rotated for best fit in cabinet. Gauge faces must be visible.
6. Optional slow-close solenoid part # SC8221G007-120VAC may be used as an alternative.
7. Optional slow-close solenoid part # SC8221G007-24VDC may be used as an alternative.

NOTE: Pipe dope must be used to seal threads. DO NOT USE TEFLON TAPE.

Figure 35 - 1" CORE Duct and Plenum Protection Manifold Detail

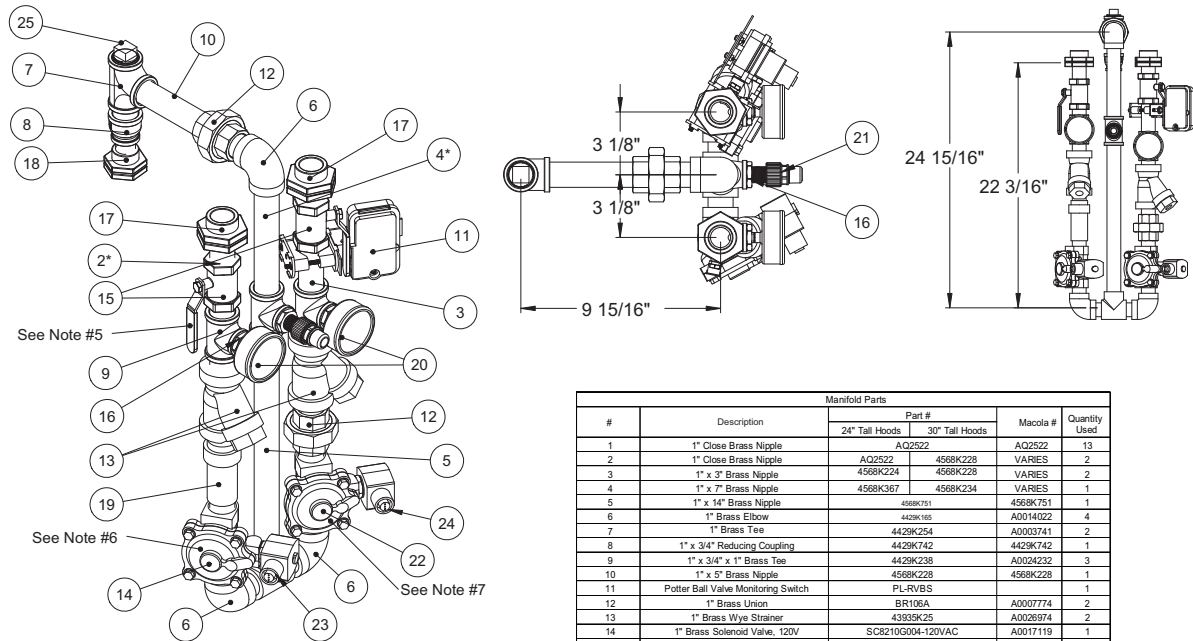

#	Description	Manifold Parts		Macola #	Quantity Used
		24" Tall Hoods	30" Tall Hoods		
1	1" Close Brass Nipple	AQ2522	AQ2522	AQ2522	13
2	1" Close Brass Nipple	AQ2522	4568K228	VARIES	2
3	1" x 3" Brass Nipple	4568K224	4568K228	VARIES	2
4	1" x 7" Brass Nipple	4568K367	4568K234	VARIES	1
5	1" x 14" Brass Nipple	4696K761	4568K751	1	1
6	1" Brass Elbow	4429K165	A0014022	4	4
7	1" Brass Tee	4429K254	A0003741	2	2
8	1" x 3/4" Reducing Coupling	4429K742	4429K742	1	1
9	1" x 3/4" x 1" Brass Tee	4429K238	A0024232	3	3
10	1" x 5" Brass Nipple	4568K228	4568K228	1	1
11	Potter Ball Valve Monitoring Switch	PL-RVBS			1
12	1" Brass Union	BR106A	A0007774	2	2
13	1" Brass Wye Strainer	4333K25	A0028974	2	2
14	1" Brass Solenoid Valve, 120V	SC8210G004-120VAC	A0017119	1	1
15	1" Manual Ball Valve	MBV-1.0NN (EC)	10406	2	2
16	3/4" To 1/4" Brass Bushing	AQ2564	AQ2564	3	3
17	1" Quick Seal	213	A0003378	2	2
18	3/4" Quick Seal	172	372	1	1
19	1" Backflow Preventer	LF7RU2-2	A0028338	1	1
20	Temperature and Pressure gauge	DP TG3-2-1/2	AQ2516	2	2
21	Surfactant Injection Point	AQ2542	A0007013	1	1
22	1" Brass Solenoid Valve, 24V	SC8210G004-24DC	A0019960	1	1
23	Solenoid Connection Cable, 120V	5J684-551-US0A	AQ3602	1	1
24	Solenoid Connection Cable, 24V	5J684-251-US0A	AQ3603	1	1
25	1" Brass Plug	4429K287	A0028378	1	1

All Nipples are Close, Unless Noted Otherwise

1-1/2" CORE Duct and Plenum Protection Manifold

1. All fittings and pipe will be brass. Drain components are chrome-plated 17-gauge brass.
2. Length and width of manifold must match measurements listed in **Figure 36**.
3. All pipe nipples are close, unless otherwise noted.
4. Valves and gauges can be rotated for best fit in cabinet. Gauge faces must be visible.
5. Optional slow-close solenoid part # SC8221G011-120VAC may be used as an alternative.
6. Optional slow-close solenoid part # SC8221G011-24VDC may be used as an alternative.
7. Slow-close solenoids cannot be used as an appliance solenoid in this location.

NOTE: Pipe dope must be used to seal threads. DO NOT USE TEFLON TAPE.

Figure 36 - 1-1/2" CORE Duct and Plenum Protection Manifold Detail

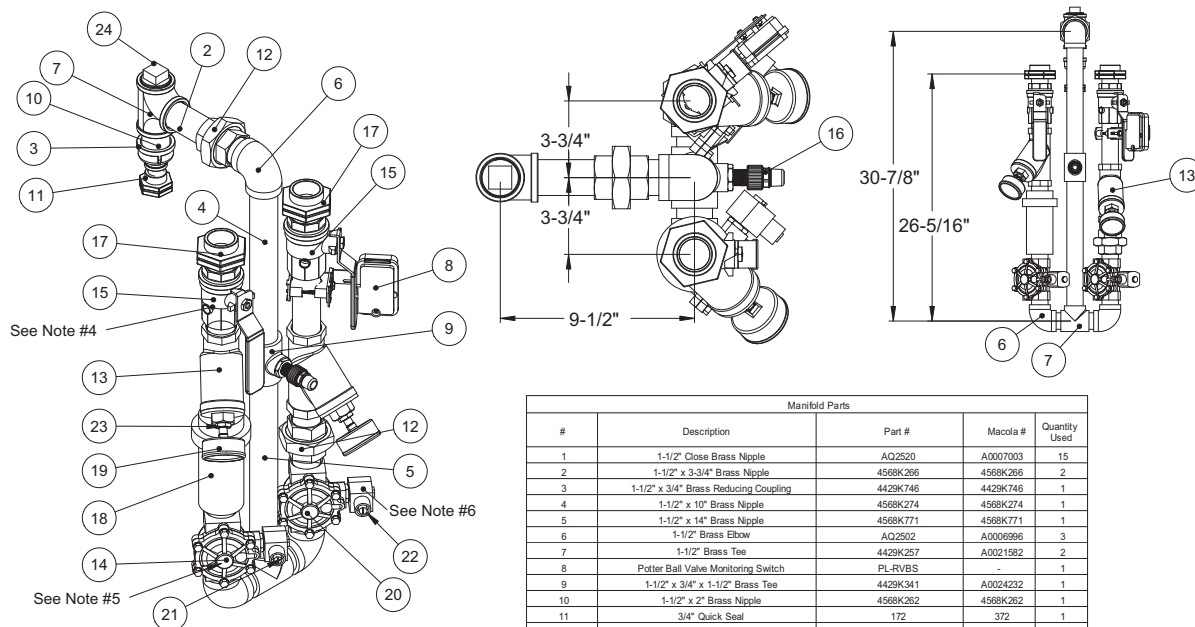

Manifold Parts				
#	Description	Part #	Macola #	Quantity Used
1	1-1/2" Close Brass Nipple	AQ2520	A0007003	15
2	1-1/2" x 3-3/4" Brass Nipple	4568K266	4568K266	2
3	1-1/2" x 3/4" Brass Reducing Coupling	4429K746	4429K746	1
4	1-1/2" x 10" Brass Nipple	4568K274	4568K274	1
5	1-1/2" x 14" Brass Nipple	4568K771	4568K771	1
6	1-1/2" Brass Elbow	AQ2502	A0006996	3
7	1-1/2" Brass Tee	4429K257	A0021582	2
8	Potter Ball Valve Monitoring Switch	PL-RVBS	-	1
9	1-1/2" x 3/4" x 1-1/2" Brass Tee	4429K341	A0024232	1
10	1-1/2" x 2" Brass Nipple	4568K262	4568K262	1
11	3/4" Quick Seal	172	372	1
12	1-1/2" Brass Union	1BR125LJ	A0023262	2
13	1-1/2" Brass Wye Strainer	4393K27	4393K27	2
14	1-1/2" Brass Solenoid Valve, 120V	SC8210G022-120VAC	A0017120	1
15	1-1/2" Gauge Port Ball Valve	4085T25	A0027373	2
16	Surfactant Injection Point	AQ2542	A0007013	1
17	1-1/2" Quick Seal	HMLJ375	376	2
18	1-1/2" Backflow Preventer	LF07S	A0027372	1
19	Temperature and Pressure gauge	DPTG3-2-1/2	AQ2516	2
20	1-1/2" Brass Solenoid Valve, 24V	SC8210G022-24DC	A0019960	1
21	Solenoid Connection Cable 120V	5J684-551-US0A	AQ3602	1
22	Solenoid Connection Cable 24V	5J684-251-US0A	AQ3603	1
23	1/2" x 1/4" NPT Bushing	4429K422	4429K422	2
24	1-1/2" Brass Plug	4429K318	A0024254	1

All Nipples are Close, Unless Noted Otherwise

Wall Mounted Self Cleaning and CORE Manifold

1. All fittings and pipe will be brass. Drain components are chrome-plated 17-gauge brass.
2. Length and width of manifold must match measurements listed in **Figure 37**.
3. All pipe nipples are close, unless otherwise noted.
4. Valves can be rotated for best fit inside cabinet.
5. CORE appliance solenoid DIN connection cables must be shipped with hoods.
6. Package also includes one vacuum breaker to be installed in the field. This will also ship loose with the package.
7. Optional Slow-Close Solenoids Part # SC8821G005-120VAC (3/4"); SC8221G007-120VAC (1"); SC8221G011-120VAC (1-1/2") may be used as an alternative.
8. Optional Slow-Close Solenoids Part # SC8821G005-24DC (3/4"); SC8221G007-24DC (1"); SC8221G011-24DC (1-1/2") may be used as an alternative.

NOTE: Pipe dope must be used to seal threads. DO NOT USE TEFLON TAPE.

Figure 37 - WM Self Cleaning and CORE Manifold Details

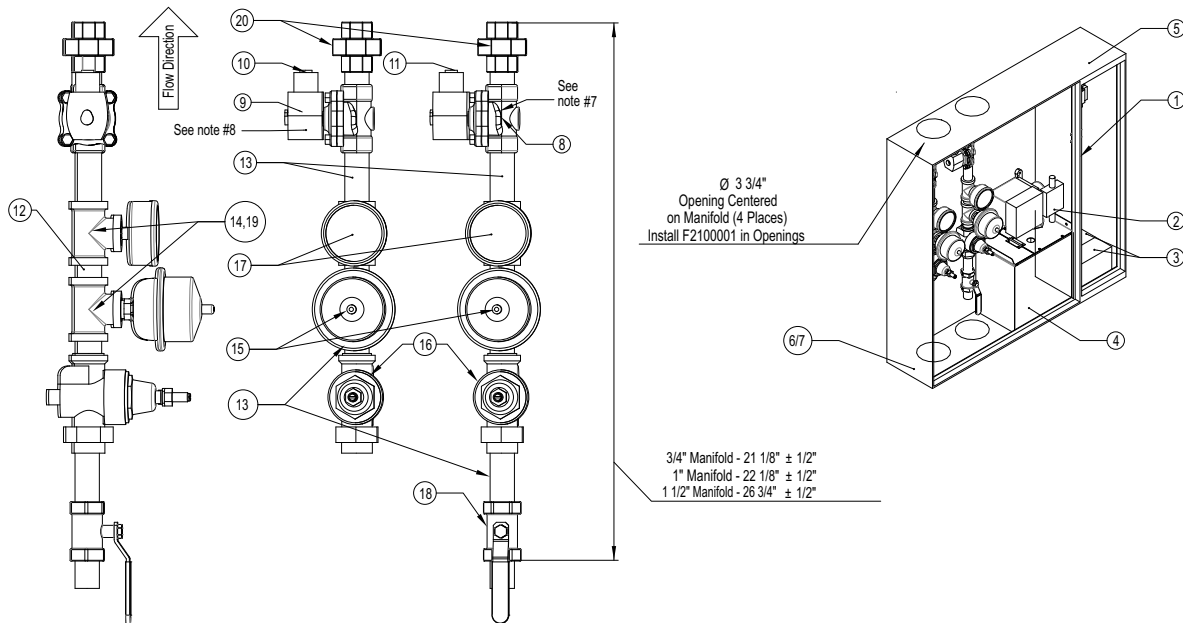

Item Number	Description	Quantity	Part Number			Quantity
			3/4" Manifold	1" Manifold	1 1/2" Manifold	
1	Core Board	1	PCBCORE			1
2	24V Detergent pump	1	50001-572			1
3	Battery	2	BP7-12			2
4	Detergent tank	1	WWSTANK2.0			1
5	24v Power Supply	1	1606-XPL			1
6	30" x 30" x 7" Stainless Cabinet (3/4" and 1" Manifolds)	1	AQ5005		N/A	1
7	30" x 30" x 10" Stainless Cabinet (1 1/2" Manifold Only)	1	N/A		AQ5006	1
8	Main Wash Solenoid (120 Vac)	1	SC8210G009-120Vac	SC8210G004-120Vac	SC8210G022-120Vac	1
9	CORE Solenoid (24 Vdc)	1	SC8210G003-24Vdc	SC8210G004-24Vdc	SC8210G022-24Vdc	1
10	24V Cord Connection	1	AQ3603			1
11	120V Cord Connection	1	AQ3602			1
12	Brass Close Nipple	3	AQ2524A	AQ2522	AQ2520	3
13	Brass 3" Nipple	4	AQ2525	AQ2523	AQ2521	4
14	Brass Tee	4	AQ2580	AQ2578	AQ2577	4
15	Water Hammer Arrestor	2		AQ2574		2
16	Water Pressure Regulator	2	LFN558M1-U (3/4)	LFN558M1-U (1)	LFN558U (1.5)	2
17	Temperature and Pressure Gauge	2	DPTG3-2-1/2			2
18	Manual Hot Water Control Valve	1	MBV-3.4NN	MBV-1.0NN	MBV-11.2NN	1
19	Brass Manifold to 1/2" Bushing	4	AQ2567	AQ2569	AQ2572	4
20	Top Connection Union	2	BR106	BR106A	1BR125UJ	2
Not Shown	Lift Off Hinges	4		AQ5012		4
Not Shown	Pipe Opening Grommet	4		F2100001		4
Not Shown	25 Feet of 1/4" Surfactant Tubing	1		Included with Surfactant Pump		1
Not Shown	1/4" Tubing Surfactant Injection Point	1		Included with Surfactant Pump		1
Not Shown	Trim Ring for Flush Mounting	1		AQ5015		1
Not Shown	Vacuum Breaker (shipped loose)	1	AQ2584	AQ2585	AQ2586	1

All Pipe Nipples Are Close, Unless Otherwise Noted.

Wall Mount CORE Manifold with Monitored Ball Valve

1. All fittings and pipe will be Brass. Drain components are Chrome-plated 17-gauge brass.
2. Length and width of manifold must match measurements listed in **Figure 38**.
3. All pipe nipples are close unless otherwise noted.
4. Valves can be rotated for best fit inside cabinet
5. CORE appliance solenoid DIN connection cable must be shipped with hoods.
6. Package also includes one vacuum breaker, to be installed in the field. This will also ship loose with the package.
7. Optional Slow-Close Solenoids Part # SC8821G005-120VAC (3/4"); SC8221G007-120VAC (1"); SC8221G011-120VAC (1-1/2") may be used as an alternative.
8. Optional Slow-Close Solenoids Part # SC8821G005-24DC (3/4"); SC8221G007-24DC (1"); SC8221G011-24DC (1-1/2") may be used as an alternative.

NOTE: Pipe dope must be used to seal threads. DO NOT USE TEFLON TAPE.

Figure 38 - WM CORE Manifold with Monitored Ball Valve Details

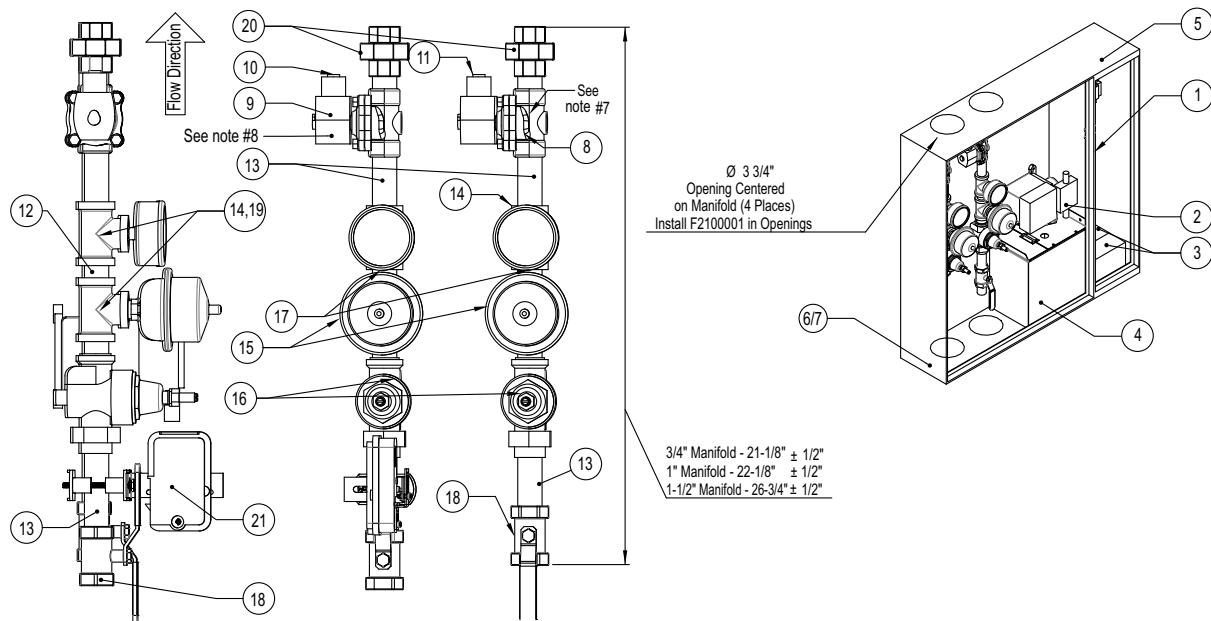

Item Number	Description	Part Number			Quantity
		3/4" Manifold	1" Manifold	1 1/2" Manifold	
1	Core Board		PCBCORE		1
2	24V Detergent pump		50001-572		1
3	Battery		BPT-12		2
4	Detergent tank		WWSCTANK2.0		1
5	24v Power Supply		1806-XPL		1
6	30" x 30" x 7" Stainless Cabinet (3/4" and 1" Manifolds)		AQ5005	N/A	1
7	30" x 30" x 10" Stainless Cabinet (1 1/2" Manifold Only)		N/A	AQ5006	1
8	Main Wash Solenoid (120 Vac)	SC8210G009-120Vac	SC8210G004-120Vac	SC8210G022-120Vac	1
9	CORE Solenoid (24 Vdc)	SC8210G003-24Vdc	SC8210G004-24Vdc	SC8210G022-24Vdc	1
10	24V Cord Connection		AQ3603		1
11	120V Cord Connection		AQ3602		1
12	Brass Close Nipple	AQ2524A	AQ2522	AQ2520	3
13	Brass 3" Nipple	AQ2525	AQ2523	AQ2521	5
14	Brass Tee	AQ2580	AQ2578	AQ2577	4
15	Water Hammer Arrestor		AQ2574		2
16	Water Pressure Regulator	LFN55BM1-U (3/4)	LFN55BM1-U (1)	LFN55BU (1.5)	2
17	Temperature and Pressure Gauge		DPTG3-2-1/2		2
18	Manual Control Valve	MBV-3.4NN	MBV-1.0NN	MBV-11.2NN	2
19	Brass Manifold to 1/2" Bushing	AQ2567	AQ2569	AQ2572	4
20	Top Connection Union	BR106	BR106A	1BR125UJ	2
21	Manual Control Valve Supervision Switch	PL-RVBS-3/4	PL-RVBS-1	PL-RVBS-1-1/2	1
Not Shown	Lift Off Hinges		AQ5012		4
Not Shown	Pipe Opening Grommet		F2100001		4
Not Shown	25 Feet of 1/4" Surfactant Tubing		Included with Surfactant Pump		1
Not Shown	1/4" Tubing Surfactant Injection Point		Included with Surfactant Pump		1
Not Shown	Trim Ring for Flush Mounting		AQ5015		1
Not Shown	Vacuum Breaker (shipped loose)	AQ2584	AQ2585	AQ2586	1

All Pipe Nipples Are Close, Unless Otherwise Noted.

Fire Protection System Printed Circuit Board

The CORE Fire System printed circuit board (**Figure 39**) is a microprocessor-based controller that provides all the necessary monitoring, timing, and supervision functions required for the reliable operation of the CORE Protection Fire System.

Under normal conditions, the “Fire System Activated” light is on. This indicates the CORE system is armed and active. If a fault is detected anywhere in the CORE system, the audible alarm will periodically sound, and the “Fire System Activated” light will flash a fault code to indicate the fault that was detected.

NOTE: CORE Boards with software version 1.68 and prior will use one brief flash every 3-seconds to indicate there are no faults in the fire system.

Fault codes consist of a series of flashes followed by a pause. Count the number of flashes between the pauses and refer to **“CORE Board Faults” on page 71**. Any fault is extremely important and must be dealt with and rectified immediately to ensure continued CORE protection.

The connections for building fire panels are located at AL1 and AL2 as dry contacts.

For remote mounted Ansul Automans, use terminals AU1 and AU2. This will provide a dry contact connection point to provide power for activating the Ansul Automan.

NOTE: When a CORE board is connected to an ECPM03 board, if a fire condition happens, the “Last Fire Info” will be stored on the ECPM03 screen. “Last Fire Info” will be available on CASLINK as well.

Figure 39 - Printed Circuit Board

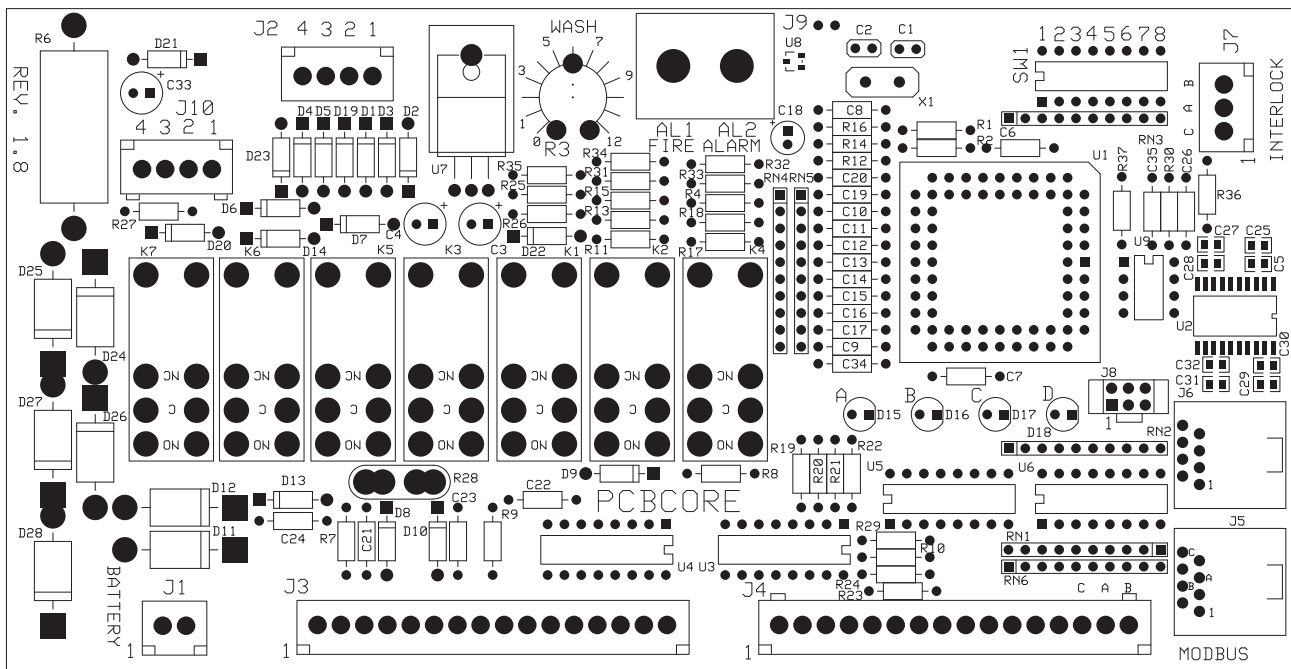

Connector Descriptions

Note: Some connections may not be used dependent on system configurations.

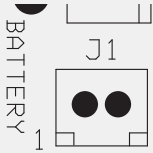
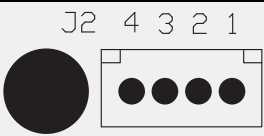
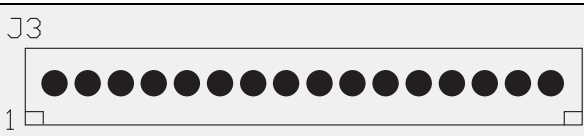
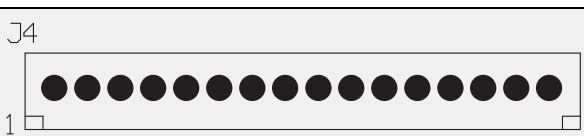
<p>Connector J1 contains battery pack connections for battery charging and monitoring.</p>	
<p>Pin 1 – Battery Positive</p>	<p>Pin 2 – Battery Negative</p>
<p>Connector J2 contains Supervised Sensor Loop connections</p>	
<p>Pin 1 – Start Positive Loop Pin 2 – Start Negative Loop</p>	<p>Pin 3 – Finish Negative Loop Pin 4 – Finish Positive Loop</p>
<p>Connector J3 contains Power Supply and Device connections</p>	
<p>Pin 1 and Pin 2 – Positive Input, Power Supply Pin 3 and Pin 4 – Negative Input, Power Supply Pin 5 – Positive Output, Gas Valve Solenoid Pin 6 – Positive Output, Surfactant Pump Pin 7 – Positive Output, Release Valve Solenoid Pin 8 and Pin 9 – 24V DC Input, Shutoff Valve Supervision</p>	<p>Pin 10 – Positive Output, CORE Appliance Water Valve Solenoid Pin 11 – Drive Output, Fire Relay Pin 12 – Drive Output, 100% Relay Pin 13 – Drive Output, Trouble Relay Pin 14 – Drive Output, Wash Relay Pin 15 – Drive Output, Spare Relay Pin 16 – Drive Output, Auto-Man Relay</p>
<p>Connector J4 contains Power Supply and Device connections</p>	
<p>Pin 1 – Positive Input, Power Supply Pin 2 – Output, Panel Mounted Audible Alarm Pin 3 – Output, Panel Mounted LED Fire/Fault Indicator Pin 4 – Output, Panel Mounted LED Surfactant Low Indicator Pin 5 – Drive Output, Cooking Equipment Disable Relay Pin 6 – Negative Input, Power Supply Pin 7 – Input, Surfactant Level Float Switch</p>	<p>Pin 8 – Input, Pump Prime/Reset Push Button Pin 9 – Input, Test Switch Pin 10 – Input, Fan Switch Pin 11 – Input, Gas Valve Reset Push Button Pin 12 – Input, Door/Tamper Switch Pin 13 – Input, Override Push Button Pin 14 – Modbus Network, Common Signal (C) Pin 15 – Modbus Network, Negative Signal (A) Pin 16 – Modbus Network, Positive Signal (B)</p>

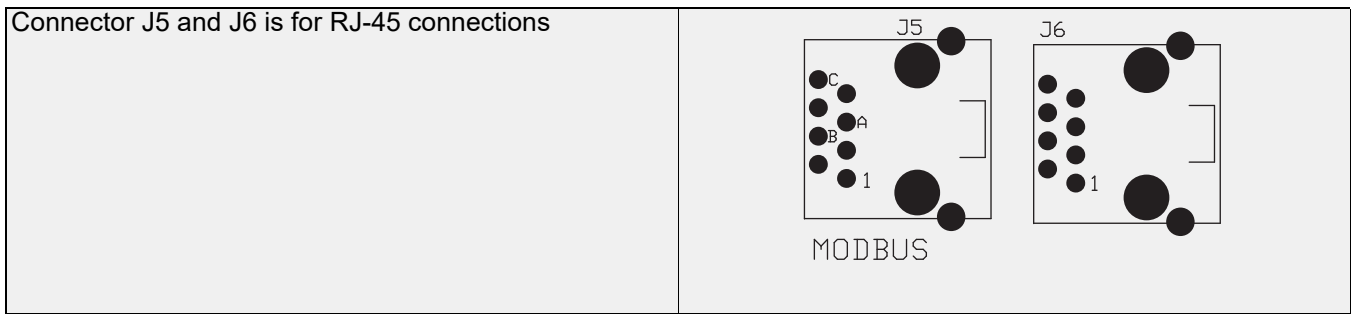

These two connections are for the Modbus Network. This network may be used by non-fire system related equipment to monitor operating conditions of the electrical (PCBCORE) board.

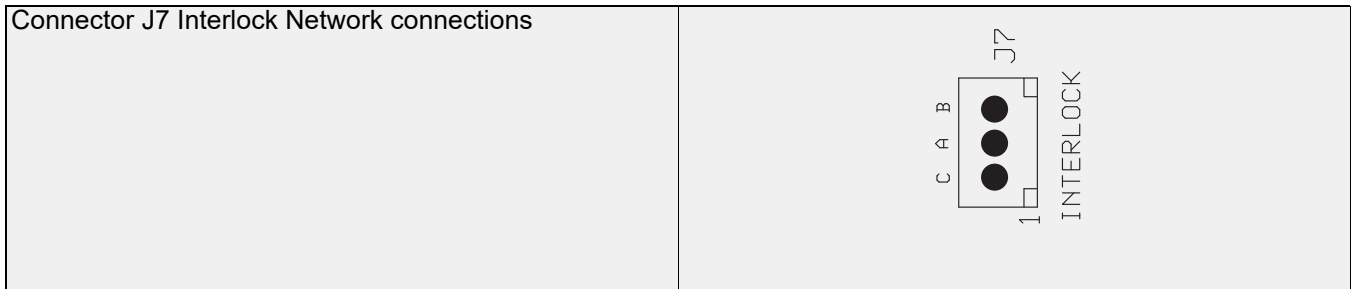

Pin 1 – Interlock Network, Common Signal (C)
Pin 2 – Interlock Network, Negative Signal (A)

Pin 3 – Interlock Network, Positive Signal (B)

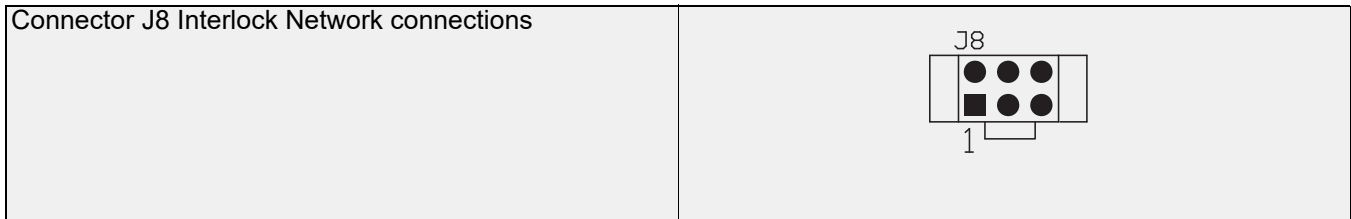

Factory Use Only

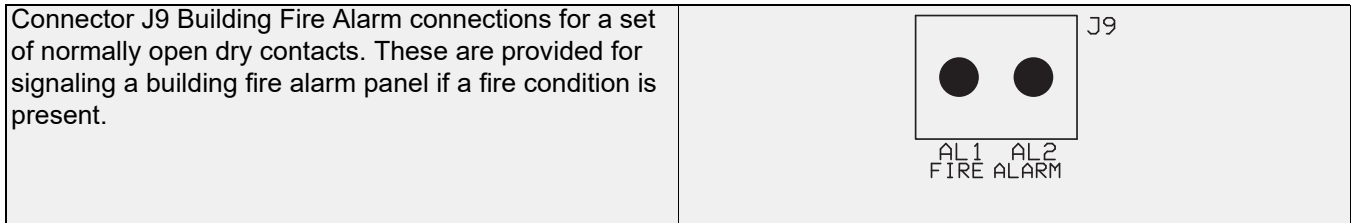

Pin 1 – Dry Contact Closure

Pin 2 – Dry Contact Closure

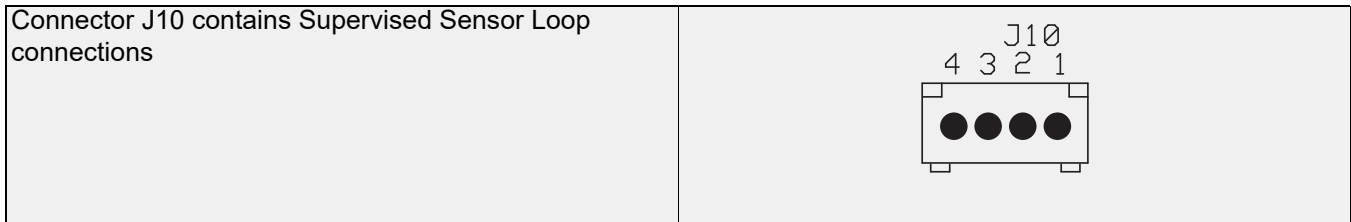

Pin 1 – Start Positive Loop
Pin 2 – Start Negative Loop

Pin 3 – Finish Negative Loop
Pin 4 – Finish Positive Loop

DIP Switch Settings

When set from the factory (**Figure 40**), switches 1, 5, and 8 are in the On (Closed) positions. Switch 2, 3, 4, 6, 7 are in the Off (Open) position. This should be considered the default positions and should not be changed.

Table 15 - DIP Switch Settings

DIP Switch #	Description				
1 through 4	DIP Switch Position				Interlock Network Address
	1	2	3	4	
	On	Off	Off	Off	1
	Off	On	Off	Off	2
	On	On	Off	Off	3
	Off	Off	On	Off	4
	On	Off	On	Off	5
	Off	On	On	Off	6
	On	On	On	Off	7
	Off	Off	Off	On	8
	On	Off	Off	On	9
	Off	On	Off	On	10
	On	On	Off	On	11
	Off	Off	On	On	12
	On	Off	On	On	13
	Off	On	On	On	14
On	On	On	On	15	
Off	Off	Off	Off	This unit is not part of an interlock network	
5	Set this switch to On (Closed) if this unit has the highest address on the interlock network. Otherwise, this switch must be Off (Open)				
6 and 7 Fire Group	6		7		Fire Group Number
	Off		Off		1
	On		Off		2
	Off		On		3
On		On		4	
8	Setting switch 8 to its On (Closed) position connects a 120 Ohm terminating resistor to the interlock network. This switch must be On if this unit is at either physical end of the interlock network cable. Otherwise, it must be Off (Open).				

Figure 40 - DIP Switch

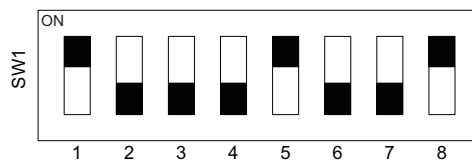

- Each unit has a unique address based on the DIP switch 1-4 settings, 15 units max on a network.
- If address is 0 (all switches off), the unit will not accept or send any network traffic.
- The unit that has switch 5 set to on will be the “master” and will be in charge of polling all the units below it and waiting for a reply. The lack of 3 replies in a row will cause an “interlock network supervision fault.” All units will be polled in a burst every 3 seconds.
- For all non-master units, the lack of being polled for 10 seconds will cause an “interlock network supervision fault.”
- Any unit detecting a fire condition will broadcast the notification once every second for as long as the condition persists.
- When the Fire condition is cleared, 10 notifications will be sent, one every second.
- Any unit detecting a supervisory fault will broadcast the notification every 2 seconds until the condition is cleared.
- When the supervisory fault condition is cleared, 10 notifications will be sent, one every 2 seconds.

Typical DIP Switch Arrangement

Only One Fire Protection System Panel on the network:

Core Board #	DIP 1	DIP 2	DIP 3	DIP 4	DIP 5	DIP 6	DIP 7	DIP 8
#1 (Hood Master)	On	Off	Off	Off	On	Off	Off	On

Two Fire Protection System (or CORE) Panels on the network:

Core Board #	DIP 1	DIP 2	DIP 3	DIP 4	DIP 5	DIP 6	DIP 7	DIP 8
#1 (2nd Hood Slave)	On	Off	Off	Off	Off	Off	Off	On
#2 (Hood Master)	Off	On	Off	Off	On	Off	Off	On

Two Fire Protection System (or CORE) Panels on the network:

Core Board #	DIP 1	DIP 2	DIP 3	DIP 4	DIP 5	DIP 6	DIP 7	DIP 8
#1 (PCU Slave)	On	Off	Off	Off	Off	Off	Off	On
#2 (Hood Master)	Off	On	Off	Off	On	Off	Off	On

Three Fire Protection System (or CORE) Panels on the network:

Core Board #	DIP 1	DIP 2	DIP 3	DIP 4	DIP 5	DIP 6	DIP 7	DIP 8
#1 (2nd Hood Slave)	On	Off	Off	Off	Off	Off	Off	On
#2 (PCU Slave)	Off	On	Off	Off	Off	Off	Off	Off
#3 (Hood Master)	On	On	Off	Off	On	Off	Off	On

Four Fire Protection System (or CORE) Panels on the network:

Core Board #	DIP 1	DIP 2	DIP 3	DIP 4	DIP 5	DIP 6	DIP 7	DIP 8
#1 (2nd Hood Slave)	On	Off	Off	Off	Off	Off	Off	On
#2 (PCU Slave)	Off	On	Off	Off	Off	Off	Off	Off
#3 (2nd PCU Slave)	On	On	Off	Off	Off	Off	Off	Off
#4 (Hood Master)	Off	Off	On	Off	On	Off	Off	On

For additional configurations, refer to **Table 15** for the electrical board (PCBCORE) DIP switch settings.

The configurations above are shown with all electrical boards (PCBCORE) in the same Fire Group and may be configured differently, even if the control panels are on the same network. Every panel with matching fire group settings (DIP switches 6 and 7) will activate simultaneously in a fire condition.

Fire Protection System Supervised Loops

The supervised loops are integral to proper operation and activation of the Fire Protection System. All systems have two supervised loops; each loop consists of two conductors, one positive and one negative. One loop is dedicated to all sensors, while the other is dedicated to all manual actuation devices (push/pull stations). The supervised loop connections are located at the front edge of the hoods for accessibility. Connections beyond the hood, like the connections at the manual actuation device, must be made with a plenum-rated wire. It is recommended to use a two-conductor Belden 6320UL, 18 AWG, wire, or similar for these connections. Refer to **Figure 41** for supervised loop details.

The supervised loop must be run through metallic conduit. Do not run wiring with high voltage wires. Verify all supervised loop wires are free from damage/stress. All supervised loop wires must be terminated in terminal blocks, junction boxes, and push-stations.

- Connections to the firestat will use two Wago connectors. One for an incoming loop and one for an outgoing loop.
- Flexible metallic conduit is used to route the wiring that connects the firestat to the remote loop junction box. Secure conduit to hood hat channel when possible.

Figure 41 - Supervised Loop Connections

1. Firestat
2. Conduit
3. Junction Box
4. Wago Connector

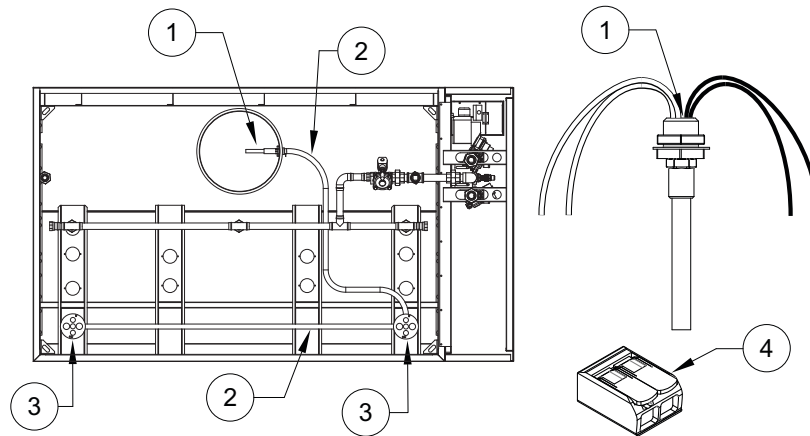

For connections on or above the hood, use Type MG or MGT wiring with Wago connectors. A Supervised Loop Connection kit is available to connect back to back or end to end hoods. This kit will come with the necessary hardware and wire.

Table 16 - Supervised Loop Components

Connection Kit Part Number	Length	Location
SLPCON-03	3 Feet	End to End Hoods
SLPCON-05	5 Feet	End to End Hoods
SLPCON-10	10 Feet	End to End and Back to Back Hoods
SLPCON-15	15 Feet	End to End and Back to Back Hoods
SLPCON-20	20 Feet	End to End and Back to Back Hoods

High Temperature Supervised Loop Components	Part Number
Type MG Wire, White, 16 AWG	441601C6.FE9
Type MG Wire, Black, 16 AWG	441601C6.FE0
Wago Connectors	221-412

Supervised Loop Electrical Details

NOTE: Place the panel in test mode when checking the supervised loop circuit.

Before checking the supervised loop circuit (**Figure 42**), verify all CORE power supplies (PS-02) are set to 27.5V +/- 0.1V DC. Check all supervised loop connections. Verify wiring is properly connected and secure. If any of the readings in **Table 17** are out of range or other faults are present, there is an issue with that loop or associated components/wiring. Refer to **page 74** for troubleshooting.

Figure 42 - Wiring for Supervised Loop

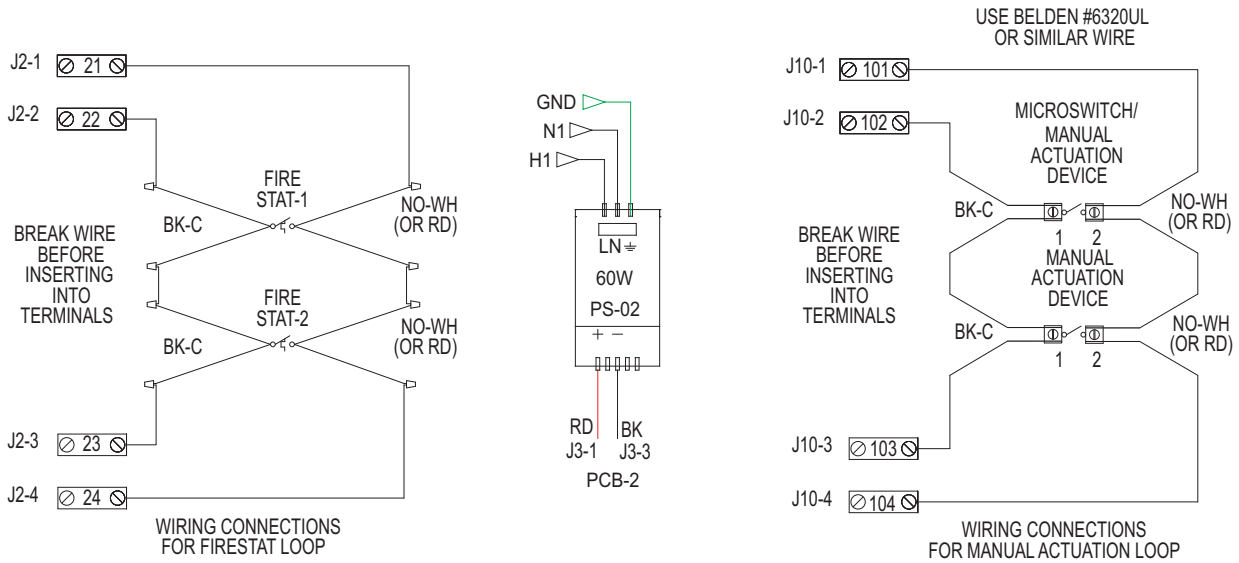

Table 17 - Supervised Loop Circuit Readings

Component Check	Procedure: Check for continuity between terminals. Place the breaker off. Disconnect the batteries at connector J1	Expected Readings
Firestat(s)	Terminals 21 and 24; Terminals 22 and 23	Continuity
	Terminals 21 and 22; Terminals 21 and 23 Terminals 24 and 23; Terminals 24 and 22	No Continuity
Manual Activation Device (MAD)	Terminals 101 and 104; 102 and 103	Continuity
	Terminals 101 and 102; Terminals 101 and 103 Terminals 104 and 103; Terminals 104 and 102	No Continuity
Component Check	Procedure: Measure voltage between terminals. Place the breaker on. Reconnect the batteries at connector J1	Expected Readings
Power Supply	PS-02 (DC+) and PS-02 (DC-)	27.5 +/- 0.1V DC
Firestat(s)	PS-02 (DC-) and Terminal 21; PS-02 (DC-) and Terminal 24 Terminal 21 and Terminal 22; Terminal 23 and Terminal 24	26.5 +/- 0.2V DC
	PS-02 (DC-) and Terminal 22; PS-02 (DC-) and Terminal 23	0 +/- 0.2V DC
	Terminal 24 and Chassis Ground	1.8 +/- 0.2V DC
Manual Activation Device (MAD)	PS-02 (DC-) and Terminal 101; PS-02 (DC-) and Terminal 104 Terminal 101 and Terminal 102; Terminal 103 and Terminal 104	26.5 +/- 0.2V DC
	PS-02 (DC-) and Terminal 102; PS-02 (DC-) and Terminal 103	0 +/- 0.2V DC
	Terminal 104 and Chassis Ground	1.8 +/- 0.2V DC

Fire Protection Manual Actuation Device

The push/pull station (**Figure 43**) is a remote manual actuation device to activate the fire system. This remote manual actuation device (push/pull station) contains one set of normally open contacts and mounts to any standard single gang junction box. When the front button is pressed, the electrical connection to the fire system is completed, thus activating the fire system.

The remote manual actuation device (push/pull station) should be mounted at a point of egress and positioned at a height determined by the Authority Having Jurisdiction (AHJ). This position is usually 10 to 20 feet from hood and 42 to 48 inches above the floor. Multiple remote manual actuation devices (push/pull stations) are acceptable to use in the fire system and are wired in parallel per the electrical schematic. The remote manual actuation device (push/pull station) is reset by twisting the push-button clockwise until the internal latch is released.

The clear protective cover must be installed to protect the device from accidental activations. This cover is provided as part of the manual actuation device. Refer to **Table 18** for device part numbers and replacement parts.

NOTE: When connecting the wires to the push/pull station, do not twist the wire ends together. Insert each wire on the opposite side of the screw.

Figure 43 - Manual Actuation Device

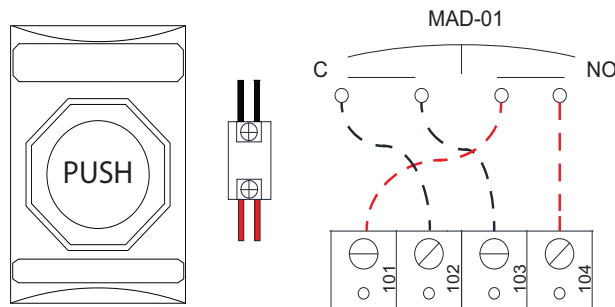

Table 18 - Activation Device Part Numbers

Part Description	Part Number
Push-Button with Clear Cover	STI-SS2431
Push-Button with Clear Cover and Horn	STI-SS2441
Blue Extension for Surface Mounted Push/Pull Stations	SF-1331
Blue Junction Box with Deep Back for Surface Mount	STI-KIT71101AB
Normally Open Contact	STI-10196
Contact Housing Assembly	SF-10197H

Trouble contacts and supervision switches from each device may be connected to the optional trouble input of the building fire alarm panel to indicate a trouble condition.

Fire Protection System Firestat

The Firestat (**page 63**) is a device installed in the riser of the hood, at the duct connection, that measures temperature. One sensor shall be installed in each exhaust riser. Secondary downstream detectors in the duct are not required except as outlined in the **Non-Solid Fuel Appliances** and **Solid Fuel Appliances** section. Sensors are not required above each appliance or in the hood grease plenum. The standard temperature setting is 360°F. Depending on heat produced by appliance, a higher rated temperature Firestat will be required. If a temperature higher than the setpoint is sensed, the Firestat contacts will close and energize the electrical control board. The fire system will activate, the system will run for a minimum of 15 minutes and then recheck the temperature. If the temperature is still higher than the setpoint, the process restarts immediately.

The supervised loop must be run through metallic conduit. Do not run wiring with high voltage wires. Verify all supervised loop wires are free from damage/stress. All supervised loop wires must be terminated in terminal blocks, junction boxes, and push-stations.

The Firestat has 2 black wires and 2 white wires. These wires must be connected to the supervised loop. Use high-temperature wiring when installing Firestat components. Wago connectors (part number: 221-412) must be used. There must be one sensor installed for every 12 feet of hood length.

Multiple sensors are wired in parallel in the supervised loop. The Firestat may be installed on the opposite side of the quick seal for access in the duct.

Non-Solid Fuel Appliances (Rated 450°F)

Non-solid fuel appliances rated for 450°F will not require additional firestats, regardless of the configuration and length of ductwork.

Non-Solid Fuel Appliances (Rated 600°F)

Non-solid fuel appliances rated for 600°F will require downstream detection if the duct run contains any horizontal section over 25 feet in length. Downstream detection should be installed at the end of a horizontal section. Duct layouts that include less than 25 feet of horizontal ductwork will not require additional detection.

Solid Fuel Appliances (Rated 700°F)

Solid fuel appliances produce effluents that can accumulate inside the duct, especially in long horizontal duct runs. Sparks from solid fuel appliances can travel into the ductwork and create fires that occur beyond the point where the hood riser Firestat can detect them. Additional downstream Firestats ensure that these duct fires are detected and the fire system actuates. Solid fuel applications require 600°F rated Firestats, and SOLO filters.

In addition to the 600°F rated Firestat, located in the hood riser, a second Firestat is required at the duct discharge for solid fuel applications when the ductwork exceeds 10 feet in length or contains horizontal runs. Even if the entire duct run is inaccessible, this additional Firestat is still needed. Mounting a Firestat in the fan may be an option. On duct runs longer than 50 feet, a third Firestat will be required somewhere in the duct run, ideally at the end of a horizontal run, if present. Duct runs longer than 100 feet will require additional Firestats, **contact your local sales office for more information.**

NOTE: When additional Firestats are required, install in an accessible location near an access door, hood riser, or fan. The door will provide access to install, clean, and replace the Firestat when needed. If a PCU is equipped with electronic detection, PCU Firestats can serve as downstream detectors, if present. The temperature rating of the Firestat in the duct must always match the temperature rating of the Firestat in the riser.

Figure 44 - Firestat Installation Details

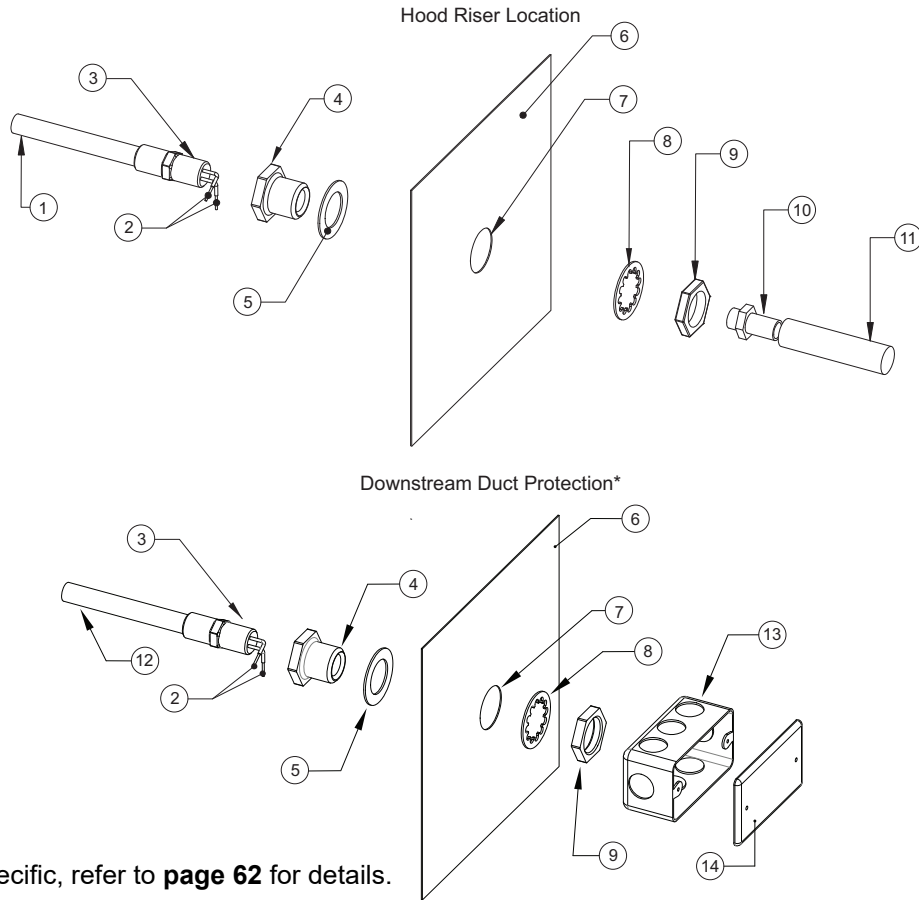

* Application specific, refer to **page 62** for details.

Firestat Components

1. Hood Riser Firestat
 - Fenwal Part Number - 12-F28021-32144-OT-360 - Normally Open, Close on Rise @ 360°F
 - Fenwal Part Number - 12-H28021-12144-OT-600 - Normally Open, Close on Rise @ 600°F
2. Wiring - 2 black wires/2 white wires.
3. Seal threads with Teflon Tape before installation
4. 1/2" NPT Quick Seal (Adapter Body) - Part Number Kit 32-00002
5. 1/2" NPT Quik Seal (Gasket) - Part Number Kit 32-00002
6. External Surface of hood/duct.
7. 1 1/8" - 1 1/4" diameter hole.
8. 1/2" NPT Quik Seal (Lock Washer) - Part Number Kit 32-00002
9. 1/2" NPT Quik Seal (Nut) - Part Number Kit 32-00002
10. 1/2" flex conduit connector - Part Number A009088
11. Flex metallic conduit to ECP junction box (closest to the hood) - Part Number A0005719
12. Duct Protection Firestat
 - Fenwal Part Number 12-F28021-005360 - Normally Open, Close on Rise @ 360°F
 - Fenwal Part Number 12-H28021-005-OT-600 - Normally Open, Close on Rise @ 600°F
13. Extension Ring - Part Number 59361-1/2
14. Extension Ring Cover - Part Number 100-BW

Hood Riser Sensor Replacement

The following instructions are for replacing a hood duct stat or fire stat located in the riser.

NOTE: Make sure the fire system is deactivated and all controls are powered down before servicing the unit. Service should only be performed by trained personnel.

1. Locate faulty sensor in hood riser. Remove the hood filters to access from the hood plenum.
2. Determine the location of the sensor's lead ends. This will either be on the top of the hood, in the junction box which has conduit routed to the riser, or in the electrical control package that is mounted on the hood (if it is a stand-alone hood).
3. Access the sensor's lead ends and remove Wago connectors. Attach a fish tape (or pulling rope) to the lead ends.
4. Unscrew the sensor from the quick seal in hood plenum. Pull leads completely out, pulling the fish tape until exposed.
5. Attach replacement sensor to fish tape and pull back through conduit until lead ends are back in the original location.
6. Replace Wago connectors on the new sensor's lead ends.
7. Twist new sensor counterclockwise, 2-1/2 turns to pre-tension wires. Thread sensor in riser quick seal (using Teflon tape on threads).
8. Replace hood filters.
9. Power up the system to test functionality.

Figure 45 - Sensor Replacement

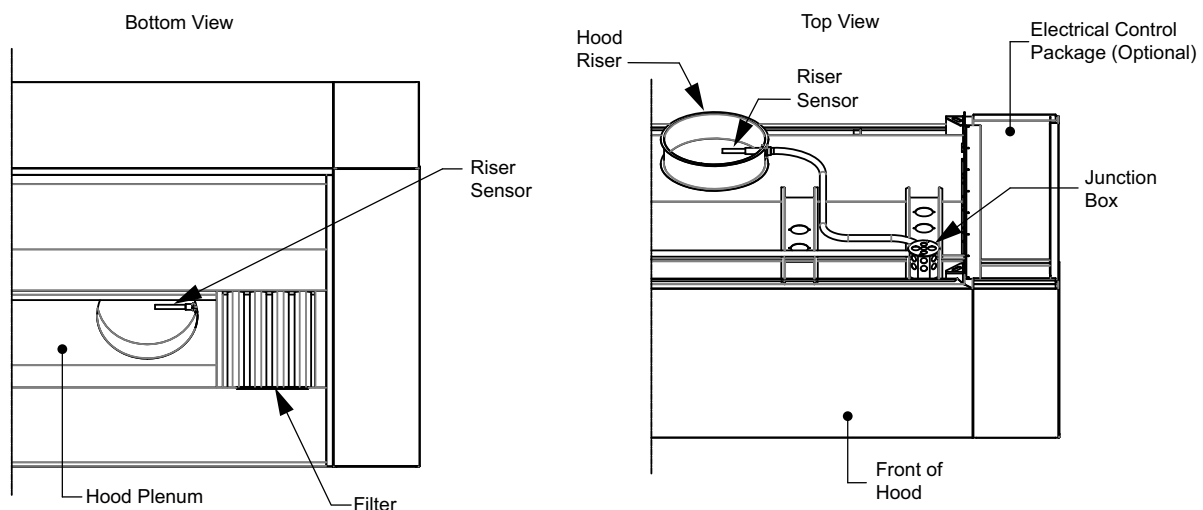

Surfactant Tank

The CORE Protection Fire System utilizes a two-gallon surfactant tank (**Figure 46**). For this package, the low-level control is located at the 1-gallon mark. In the event of a fire, surfactant is continuously injected into the water spray to help suppress the fire. One gallon of surfactant will last for approximately 15 minutes of fire protection. In the event that the low-level sensor is activated, an “Add Surfactant” light will illuminate on the control panel. To reset light, simply fill the surfactant tank with surfactant.

NOTE: SC-5 surfactant from 20/10 Products Incorporated must be used. Lift the front lid to fill the tank, fill to top.

Figure 46 - Surfactant Tank Details

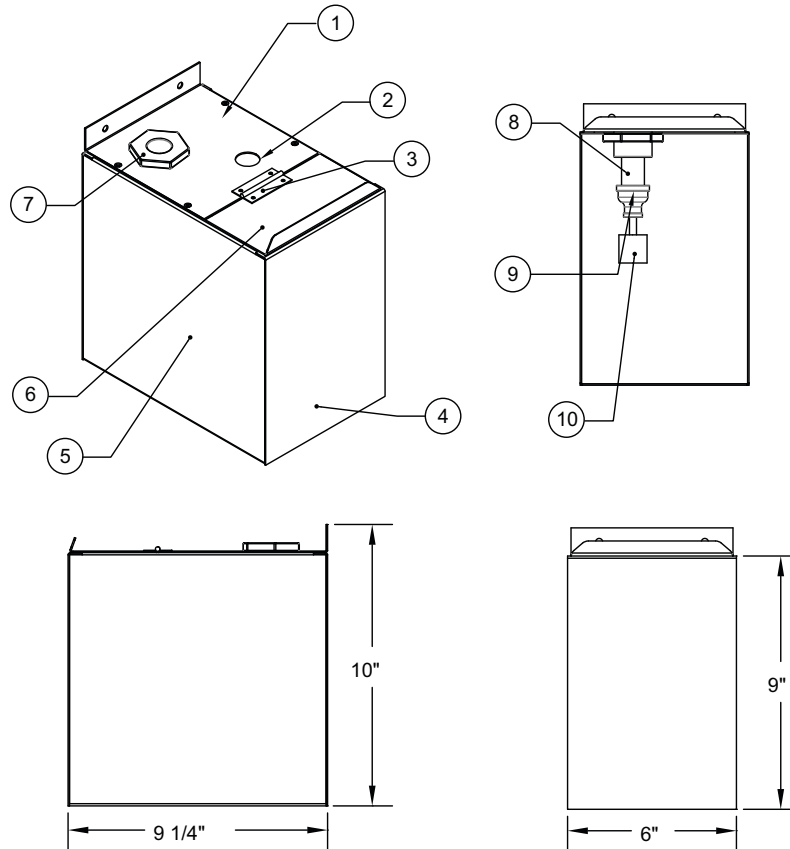

Callout	Description	Part Number
1	Rear Lid	WWSTRLID
2	7/8" Grommet	N/A
3	Spring Hinge	531944-0104
4	Tank Side	WWSTSIDE
5	Tank Body	WWSTBODY
6	Front Lid	WWSTFLID
7	1/2" Quick Seal	32-00002
8	2" x 1/2" Brass Nipple	4568K173
9	1/2" to 1/8" Reducing Coupling	4429K733
10	Level Switch	AQ5510

CORE Protection Waterline Supervision

The CORE Total Flood manifold is listed for use with water pressures up to and including 70 psi (operating pressure) and 125 psi (static pressure). When the inlet connection to the manifold exceeds the max listed pressures, a pressure reducing valve must be installed (**Figure 47**). The valve is capable of reducing the wet pipe sprinkler line supply pressure and flow rate down to the CORE control package requirements. The valve is capable of shutting down the water flow, therefore it must be monitored to ensure the valve is open. The pressure reducing valve is an Elkhart Brass UR series and includes a supervision switch. The valve is available in 1-1/2" NPT (UR-30-Series) and in 2-1/2" NPT (URFA-Series). Refer to **Table 19** for pressure reducing valve ratings.

The optional Pressure Supervision Switch (PL-PS402), is used to verify incoming water pressure. This switch is preset at 40 psi, but is adjustable up to 60 psi, to account for different hood system lengths.

Figure 47 - Pressure Valve

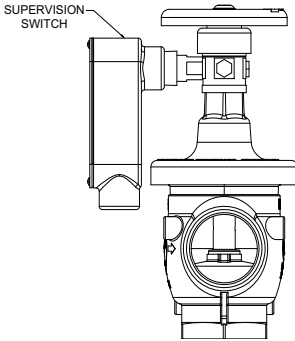

UR Valve	Outlet Pressure Pct (%)	Max Pressure (PSI)	Supervision Switch
UR-30-XN	31%	300	98409211
UR-30-ZN	54%		
URFA-20-S	Variable	400	98409011

Table 19 - Pressure Valve Specifications

Valve Type	Incoming Pressure (psi)												
	50	60	70	80	90	100	110	120	130	140	150	160	170
UR-30-ZN (Outlet Pressure psi)	15.5	18.6	21.7	24.8	27.9	31	34.1	37.2	40.3	43.4	46.5	49.6	52.7
UR-30-XN (Outlet Pressure psi)	27	32.4	37.8	43.2	48.6	54	59.4	64.8	70.2	75.6	81	86.4	91.8
URFA-20-S (Outlet Pressure psi)	Variable												

The CORE panel contains two isolated inputs for auxiliary supervision of pressure reducing valves and pressure switches. The supervision switch that comes with the UR valves has one single-pole, single-throw switch with a pair of redundant wires. The optional pressure supervision switch has two single-pole, double-throw switches. Either switch may be wired in parallel to the CORE panel terminals H1D and 39. When a fault is detected, the CORE board will shut down the gas valve and shunt trip, trigger a local trouble signal, and alert all attached CORE packages.

Alternatively, the switches from each device could be connected to the trouble input of the building fire alarm panel to indicate a trouble condition. Refer to **Figure 48** for connections.

Figure 48 - CORE Control Connections

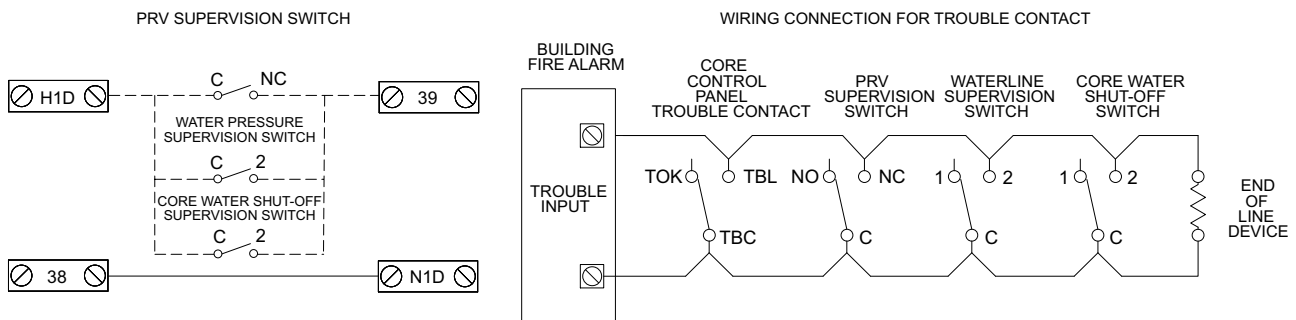

Battery Backup

Important!

The battery backup system requires that the batteries be changed every 2 years, from the date of fire system commissioning, maximum. Failure to do this will result in a void in product reliability and may cause severe damage to facility due to loss of fire protection.

The fire protection system contains a battery backup. During a power loss, the “Fire System Activated” light will flash 11 times between pauses indicating the power loss.

The batteries must be replaced every 2 years, from the date of fire system commissioning. Part number PS-1270-F2, two are required. Although the batteries are hot-swappable, which means they can be replaced while there is input power to the control, **for your safety, all sources of power must be removed from the control before replacing the batteries.** To replace the batteries, unplug the battery cable from the J1 connector on the electrical board (PCBCORE). Then remove the retaining strap holding the batteries in place. Remove the batteries from the cabinet. Transfer the fuse and cable set from the old batteries to the new batteries being extremely careful to observe the RED and BLACK lead and terminal colors. Reinstall the batteries in the cabinet and reconnect the battery plug to J1. The batteries are lead-acid type and are recyclable; **please dispose of the old batteries properly.**

During extended periods of inactivity where the fire protection system will be without AC power for more than 2 days, such as a shutdown or natural disaster, it is best to decommission the fire system by disconnecting the batteries. This will prevent any damage to the batteries through complete discharge. When the system becomes active again, commission the system by reconnecting the batteries and allow the batteries to charge for 48 hours.

The fire protection system is supplied with 14-amp hours of backup battery capacity. Per NFPA 72 10.5.6.3, the system requires 1.66 amp hours of battery capacity.

Power Supply Adjustment

To properly charge the batteries, the power supply must be adjusted to output 27.5V DC. This can be checked with an accurate digital voltmeter placed across Terminals H1D and N1D. To adjust the output voltage, place a small flat-bladed screwdriver into the yellow dial. Turn the dial clockwise, this will increase the voltage.

Figure 49 - Battery Backup

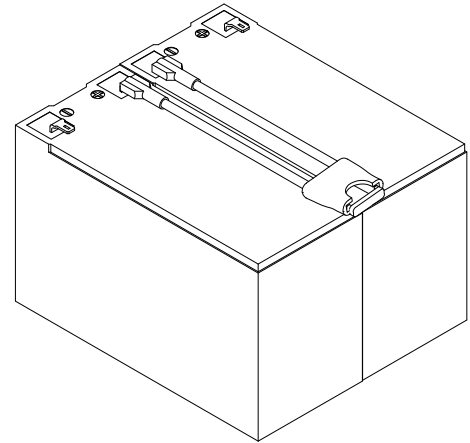
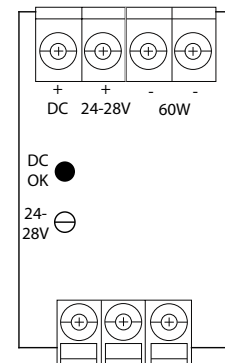

Figure 50 - Power Supply



Heat Recovery Coil (Optional)

An optional heat recovery coil is available with CORE hoods. The coils are factory-installed under each hood duct (riser) connection. Warm exhaust air passes through the coils and heats the water running through the coils. The water is used to pre-heat the water supply to the hot water heater(s) for the facility. The self cleaning function of the hood continually cleans the surface of the coil to ensure proper heat transfer. It is very important to ensure that the high-efficiency hood filters remain in use in the hood.

Each hood equipped with a coil system has a **3/4 inch NPT inlet and outlet connection**. If multiple hoods are on the same system, they should be piped in series, before the water heater, to maximize energy recovery. If the coil pressure drop is excessive for an "in series" configuration, the coils may be piped in parallel to reduce water pressure drop. It is important to keep the piping runs similar when piping in parallel to keep flow rates through all coils similar. Field pipe size must be sized to provide adequate hot water for the building appliance usage, including the self cleaning operation of the hood. If the hood covers multiple appliances, the coil performance will be best if the water enters the end of the hood that covers the lower temp appliance first. **The max static water pressure in the system should be 150 psi.**

It is recommended that an expansion chamber, check valves, ball valves, and pressure relief valves are field installed in the system, as shown in the diagram below. As the water heats up in the system, the water volume can increase, therefore causing the pressure to increase.

Figure 51 - HRC Typical Installation

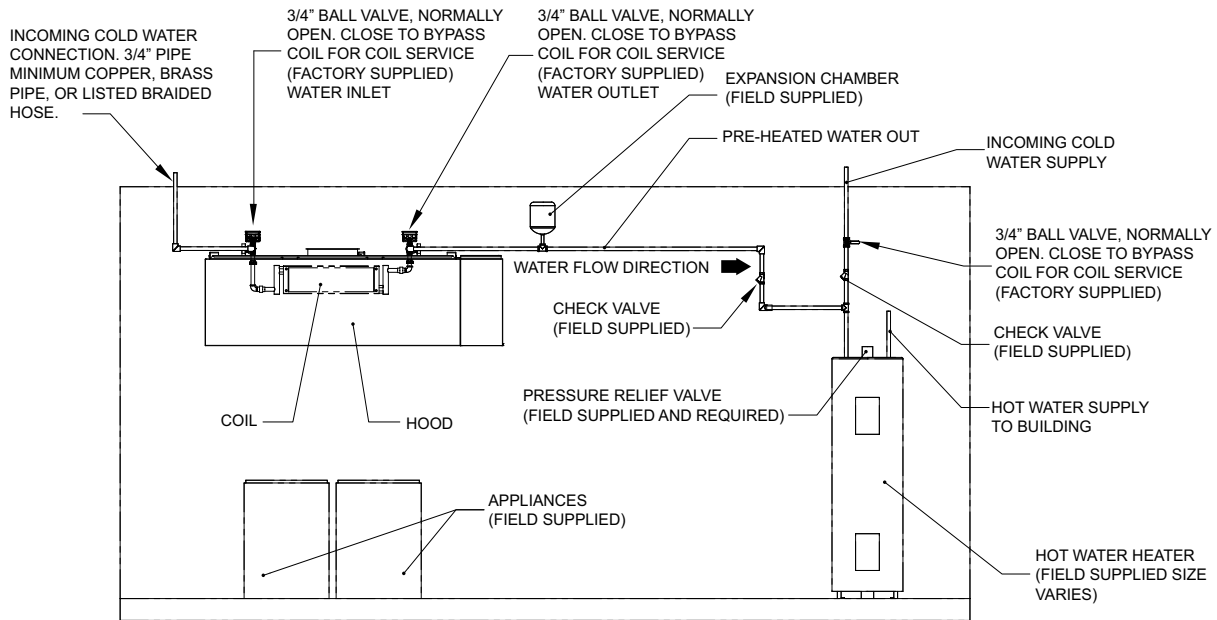

Each coil is factory installed and is equipped with manual shut off valves on both the inlet and outlet for service. With these valves in the off position, no water will flow through the coils. The coils are also constructed with brass union connections, so the coil can be removed for further cleaning or service. When removing a coil, break the unions loose and allow the water to drain into the hood trough to empty the coil. It is recommended that a second water supply be piped directly to the hot water heater, as shown in the diagram above so that the facility will have hot water during coil service. Check valves and ball valves should be field installed, as illustrated to allow for proper service.

Inlet and outlet pressure/temperature gauges are installed to monitor the performance of the coil. With water flowing and the hoods operating over hot appliances, there should be a 5-30°F temperature rise noticed from the coil inlet to the outlet. Air pressure drop through the coil is negligible but can be estimated with the formula below. Water pressure drop is more significant and can be estimated with the formula below or from **Table 20 on page 69**.

Coil Air Pressure Drop (in. w.c.) = 1.25E-8 x CFM²

Coil Water Pressure Drop (psi) = 0.054 x GPM²

Coil Water Pressure Drop (FT. H2O) = 0.125 x GPM²

Water temperature can also be remotely monitored. Thermistors are installed on both the entering and leaving side of each coil for temperature monitoring. Thermistors are rated at 10Kohm and have a 2 wire connection. These get connected to the packaged prewire controller or building monitoring system. Reference the CASLink manual for more information regarding sensor wiring.

Figure 52 - Thermistor Sensor Installation Details

Parts List

#	Description	Part Number	Qty.
1	Coil	5WS0605A-7.5x24-E	1
2	Extension Ring Cover	100-BW	1
3	Conduit Locknut	LN101SC	2
4	Junction Box	58361-1/2	1
5	Thermistor Temperature Sensor	A/CP-PO-4"-EXPL-HT	1

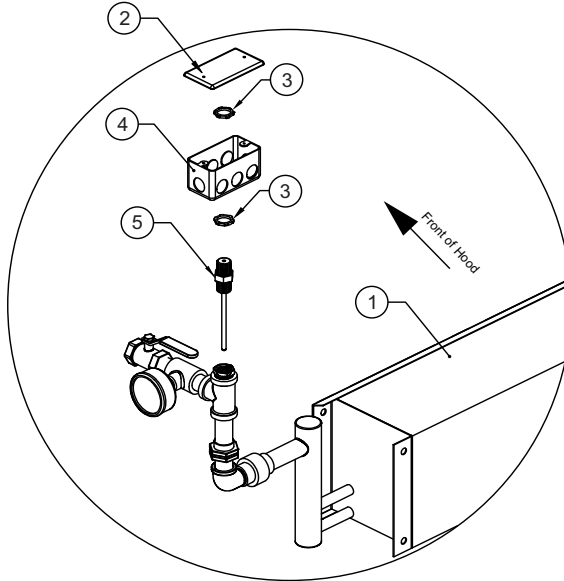

Table 20 - Water Pressure Drop through Single Coil (Add multiple coils together)

Water Flow Rate (GPM)	Coil Water Pressure Drop (FT. H2O)	Coil Water Pressure Drop (PSI)
0.5	0.03	0.01
1.0	0.13	0.05
1.5	0.28	0.12
2.0	0.50	0.22
2.5	0.78	0.34
3.0	1.13	0.49
3.5	1.53	0.66
4.0	2.00	0.87
4.5	2.53	1.10
5.0	3.13	1.35
7.5	7.03	3.04
10.0	12.5	5.41
15.0	28.13	12.18
20.0	50.00	21.65

TROUBLESHOOTING

Table 21 lists out causes and corrective actions for possible problems with the system. Review this list prior to consulting the manufacturer.

Table 21 - Fire Protection System Troubleshooting

Problem	Potential Cause	Corrective Action
Exhaust fan is ON and supply fan will not start	Broken supply fan belt	Replace fan belt.
	Fire system not armed	Fire system distributor must arm fire system.
“Fire System Activated” light is on	Fire system is activated	Verify fire is out and reset fire system.
Audible alarm is sounding	Fire system is activated	Verify fire is out and reset fire system.
“Fire System Activated” LED is flashing	A fault has been detected in the Fire Protection System	Count the flashes and refer to “Appliance Shutdown in Fault Conditions” on page 72.
Gas Valve does not close	Debris on gas valve seal	Fully clean gas valve and strainer.
Fire system will not turn OFF	Duct sensor is hot	Heat has activated the duct sensor. Remove heat source or let the system extinguish the fire. Once heat source or problem is resolved, press reset button on the face of the electrical control package.
	Remote Manual Actuation Device has been pushed	Reset remote push station (twisting clockwise until reset.) once fire is out. Press reset button on the face of the electrical control package.
	Fire system is running on a timer	Make sure the duct sensor is cool and push station is reset, then press reset button on the face of the electrical control package.
Add surfactant light is ON	Surfactant level is low	Add surfactant.

CORE Board Faults

When there are no faults in the fire system, the LED light will stay solid. When there is a fault, the LED light will flash with a short break. Count the flashes then wait for the short break to determine the fault.

NOTE: CORE Boards with software version 1.68 and prior will use one brief flash every 3-seconds to indicate there are no faults in the fire system.

Catastrophic faults

Number of Flashes	Fault Condition	Corrective Action
1	Invalid Activation	Check for external voltage being applied at J3-7 and J3-10.
2	CORE Water Solenoid	Check solenoid and wiring to solenoid, replace as needed.
3	CORE Appliance Solenoid	Check solenoid and wiring to solenoid, replace as needed.
4	Auxiliary Fault	Check supervised Pressure Regulating Valves (optional) and Pressure Switches (optional).
5	Microcontroller Fault	Replace CORE printed circuit board.

Critical faults

Number of Flashes	Fault Condition	Corrective Action
6	CORE Surfactant Pump	Check surfactant pump motor and wiring to the motor, replace as needed.
7	Supervised Loop	Check the installation of the wiring to all the manual actuation devices (push stations) and firestats. Verify connections are secure and tight. Check for open circuits in the wiring. Repair or replace wiring as needed. Refer to “Supervised Loop/Power Supply Troubleshooting” on page 74.

Important faults

Number of Flashes	Fault Condition	Corrective Action
8	Ground Fault	Check the installation of the wiring to all the manual actuation devices (push stations) and firestats. Verify connections are secure and tight. Check for a short to ground in the wiring. Repair or replace wiring as needed. Refer to “Supervised Loop/Power Supply Troubleshooting” on page 74.
9	Surfactant Low	Add surfactant. Check/replace float switch.
10	Battery Voltage Low	Replace the batteries. Wait for batteries to recharge if there was a power failure.
11	AC Power Failure	Check breakers, call power company.
12	Door Tamper Switch	Close cabinet door.
13	Test Mode	Place switch in armed position when testing is complete.
14	CORE Interlock	Check Dip Switches on all boards and RS-485 network wires connecting boards.
15	Fault on Hood in Network	Check all hoods in CORE Board network for faults.
16	Fault on PCU in Network	Check all PCUs in CORE Board network for faults.

Appliance Shutdown in Fault Conditions

The system is equipped to shut down the appliances if a fault condition is present. **Table 22** displays fault conditions that affect the appliances' fuel and power sources, alarm muting, and local trouble relay.

NOTE: CORE Boards with software version 1.68 and prior will use one brief flash every 3-seconds to indicate there are no faults in the fire system.

Table 22 - Appliance Fault Conditions

Number of Flashes	Fault Condition	Gas Valve Shut Down		Shut Down Shunt Trip Breaker and UDS Kill Switch		Mute Local Alarm 4 Hour Reset	Local Trouble Relay
		Local System	Networked System	Local System	Networked System		
Catastrophic Faults							
1	Invalid Activation	X	X	X	X		X
2	CORE Water Solenoid	X	X	X	X		X
3	Appliance Solenoid	X	X	X	X		X
4	Auxiliary Fault	X	X	X	X		X
5	Microcontroller Fault	X	X	X	X		
Critical Faults							
6	CORE Surfactant Pump					X	X
7	Supervised Loop Fault	X	X	X	X		X
Important Faults							
8	Ground Fault					X	
9	Surfactant Low					X	
10	Battery Voltage Low					X	X
11	AC Power Failure	X	X	X**	X**		X
12	Door Tamper Switch					X	
13	Test Mode	X	X	X	X		
14	CORE Interlock					X	
15	Fault on Hood in Network					X	
16	Fault on PCU in Network					X	

Local Alarm Muting

Pressing the fire system reset button can mute the local alarm. This will disable the sounder for 4 hours under specific conditions. **Table 22** shows which errors can be muted. It should be noted that the fault will not clear until the fault condition is corrected.

Test Mode

Test Mode allows the system to be tested with operational appliances without discharging the system on the appliances. Once the appliances are started, test mode can be entered without the appliances shutting down for 15 minutes. However, once the fire system is activated, the shunt trip (electric appliances) and the gas valve will be locked out until test mode is deactivated. ****During AC power failure, all gas appliances will be shut down. Electrical appliances will shut down on building power loss.**

Self Cleaning Hood Troubleshooting

The following table lists causes and corrective actions for possible problems with self cleaning hoods. Review this list before consulting manufacturer.

Table 23 - Self Cleaning Hood Troubleshooting Chart

Problem	Potential Cause	Corrective Action
Plenum not being cleaned	No Water Pressure	Verify hot water pressure >30 psi. Open manual valve if closed.
	Clogged nozzles	Clean or replace nozzles.
	Timer Settings improperly set	Wash timer should be set for approximately 3 minutes.
	No water pressure	Turn the main building water valve on.
	Nozzle spray pattern incorrect	Nozzles must be pointed toward the back of the plenum
	No Surfactant	Add surfactant.
Leaking Manifold Pipes	Pipes not tight or sealed	Reseal and tighten pipes.
Water Leaking from Vacuum Breaker	Riser nozzle installed too high	Verify that the vacuum breaker is installed higher than all downstream piping components.
Add Surfactant Light On	Low Surfactant Level	Add surfactant
Water leaks out of Filters	Filters have gaps between them	Add filter drip blanks or reorient filters.
Water Overflows Grease Trough	Clogged Drain	Clean rain or grease trap.
	Wrong Filters Installed	Install proper filters per Manufacturer.
	Water Pressure Too High	Water pressure should be 70 psi max.
	Wash Timer Set Too Long	Reduce wash time.
	Nozzles are Loose	Tighten nozzles.
	Filters are Clogged with Grease	Clean filters.

Supervised Loop/Power Supply Troubleshooting

NOTE: Place the panel in test mode during diagnostic testing.

Before troubleshooting, verify all power supplies (PS-02) are set to 27.5V DC. Verify all circuit checks from “**Supervised Loop Electrical Details**” on page 60. If any readings are not in range, there is an issue with that loop or associated components/wiring. Refer to **Table 24** for troubleshooting.

Table 24 - Common Wiring Troubleshooting Chart

Problem	Potential Cause	Expected Results +/- 0.2	Corrective Action
Supervised Loop Fault	Open Supervised Loop between Terminals 21 and 24.	<ul style="list-style-type: none"> Terminal 21 to PS-02 (DC-) = 26.5V DC Terminal 21 to Terminal 22 = 26.5V DC Terminal 24 to PS-02 (DC-) = 26.5V DC Terminal 24 to Ground = 1.8V DC 	Locate and repair faulty wiring in the 21-24 supervised loop.
	Open Supervised Loop between Terminals 22 and 23.	<ul style="list-style-type: none"> Terminal 22 to PS-02 (DC-) = 0V DC Terminal 23 to PS-02 (DC-) = 0V DC Terminal 23 to Terminal 24 = 26.5V DC 	Locate and repair faulty wiring in the 22-23 supervised loop.
	Open Supervised Loop Push-Station (Terminals 101 and 104)	<ul style="list-style-type: none"> Terminal 101 to PS-02 (DC-) = 26.5V DC Terminal 101 to Terminal 102 = 26.5V DC Terminal 104 to PS-02 (DC-) = 26.5V DC Terminal 104 to Ground = 1.8V DC 	Locate and repair faulty wiring in the 101-104 supervised loop.
	Open Supervised Loop Push-Station (Terminals 102 and 103)	<ul style="list-style-type: none"> Terminal 102 to PS-02 (DC-) = 0V DC Terminal 103 to PS-02 (DC-) = 0V DC Terminal 103 to Terminal 104 = 26.5V DC 	Locate and repair faulty wiring in the 102-103 supervised loop.
Ground Fault	Terminals 22 or 23 are shorted to chassis ground. *24V DC PS-02 (DC-) Wiring or Components.	Chassis Ground to PS-02 (DC-) = 24.4V DC	Locate and repair shorted wiring between 22-23 supervised loop and ground.
	Terminals 21 or 24 are shorted to chassis ground. **24V DC PS-02 (DC+) Wiring or Components.	Chassis Ground to PS-02 (DC+) = 2.7V DC	Locate and repair shorted wiring between 21-24 supervised loop and ground.
	Interlock Network Issue	Check battery voltage and supervised loop wiring with other packages that are interlocked in the network.	Locate and repair faulty wiring in the circuit. Replace batteries.
AC Power Failure	120V AC Input Power Supply Interrupted.	H1 to N1 = 110V to 125V AC	Verify constant input power between H1 and N1. Check wiring to L/N terminals on PS-02. Locate and repair faulty wiring in the circuit.
Battery Voltage Low	Faulty Battery or Power Supply (PS-02).	J1-1 to J1-2 = 23.5V to 24.5V DC	Verify there is 12V DC to each battery connection. Locate and repair faulty wiring in the circuit. Replace batteries.
	Interlock Network Issue.	Check battery voltage and supervised loop wiring with other packages that are interlocked in the network.	Locate and repair faulty wiring in the circuit. Replace batteries.

*** Components that may cause this fault are: Gas Valve, Surfactant Pump, Water Solenoid(s), Release Solenoid(s).**

**** Components that may cause this fault are: 24V Relays, Trouble Relay (when energized), 24V LED Lights.**

NOTE: If an abnormal reading is present, disconnect potential components/wiring one at a time, while continuing to take readings, to locate the source of the ground fault.

MAINTENANCE

To guarantee trouble-free operation of this system, the manufacturer suggests following these guidelines. Most problems associated with unit failures are directly related to poor service and maintenance. Record any maintenance or service performed on this equipment in the documentation section located at the end of this manual.

General Maintenance

1. Hood filters must be maintained on a daily basis to ensure proper airflow and grease extraction.
2. All water connections must be verified for tightness and leak-free operation.
3. The "Add Surfactant" indicating light will illuminate when the surfactant tank is 1/2 empty. Surfactant must be added immediately to guarantee proper cleaning of the hood duct and plenum and proper fire protection.

NOTE: Filters must be removed from the hood every 3-months. Inspect and clean filters per the recommendations in the Hood Installation, Operation, and Maintenance Manual.

ATTENTION: When servicing or cleaning ductwork, all Hood CORE, PCU CORE, and interlocked fire systems must be placed in test mode to prevent accidental discharge.

Every 6 months

1. Clean all duct sensors in hood duct connections (if equipped), inspect the hood duct and plenum areas for excess buildup of grease/creosote.
2. The mainline strainers in the manifold must be cleaned.
3. Verify proper system activation via the supervised loops. This includes all firestats, push stations, and any other activation points in the supervised loop.
4. Check surfactant injection and battery backup.
5. Check all nozzles for proper and evenly distributed water flow. If nozzles are clogged, clean or replace.
6. Check drain(s) on hood to verify there is no blockage. Improper drainage could cause hood leaks or water to back up into trough and overflow onto appliances.
7. Inspect the surfactant pump for proper operation and ensure liquid level sensor in the surfactant tank is operational. Test by manually lowering the sensor to verify if the "Add Surfactant" light illuminates.
8. Verify the system has proper water pressure and temperature per the labels on the unit.
9. Check gas valve operation to ensure the gas valve fully closes during system activation. Also, clean the strainer upstream of gas valve.
10. Fill surfactant tank with surfactant.

Every 2 Years

1. Replace batteries for the CORE Protection Systems. The replacement battery part number is PS-1270-F2; two are required. Once the battery is disconnected, the connected equipment is not protected from power outages. The new battery must be installed immediately. Refer to the replacement battery installation guide for more details.
2. Inspect the condition of all wires and plumbing. Plumbing should be free of corrosion, and wire insulation must be in good condition.

Decommissioning

If it should become necessary to disconnect the CORE system from AC power for an extended period of time (more than 2 days), the batteries should be disconnected to prevent them from being damaged due to complete discharge.

After A Fire

1. Inspect and/or Replace all nozzles.
2. Inspect all piping connections for tightness.
3. Inspect all hood lights for proper seals and security.
4. Inspect all wiring and Hood insulation to ensure all are in good condition.

Start-up and Maintenance Documentation

**START-UP AND MEASUREMENTS SHOULD BE PERFORMED AFTER THE SYSTEM HAS BEEN INSTALLED
(Warranty will be void without completion of this form)**

Job Information

Job Name		Service Company	
Address		Address	
City		City	
State		State	
Zip		Zip	
Phone Number		Phone Number	
Fax Number		Fax Number	
Contact		Contact	
Purchase Date		Start-Up Date	

CORE System Verification

Hood Information - Plumbing, Self Cleaning

Refer to the start-up procedure in this manual to complete this section.

Name Plate and Unit Information	
Hood Model Number	
Serial Number	
Volts	
Hertz	
Phase	

Field Measured Information	
Input Voltage	
Check all nozzles are secure	
Open all valves to hood	
Fill surfactant tank	
Set all timers	
Check fan operation	
Operate wash cycle	
Verify surfactant pump operation	
Verify surfactant line connection	
Verify hot water connection	
Verify hot water pipe size is 3/4" or larger	
Verify hot water pipes are insulated	
Verify operating water pressure (70 Max)	
Verify max static water pressure (125 Psi)	
Verify water temperature	
Measure end-to-end connection pipe	
Measure back-to-back connection pipe	
All plenum connections made (if multiple hoods)	
All appliance connections made (if multiple hoods)	
Check for leaks in the manifold	
Check for leaks through filters	
Verify water is draining properly	
Verify all drains are piped to floor drain or grease trap	

Hood Information - Electrical

Refer to the start-up procedure in this manual to complete this section.

Name Plate and Unit Information	
Hood Model Number	
Serial Number	
Volts	
Hertz	
Phase	

Field Measured Information	
CORE Control Panel Wired	
All Fans are wired into the Control Panel and are properly operating	
Shunt Trip Breaker wired (if required)	
UDS Appliance Kill Switch (if equipped) wired	
Gas Valve Wired (if 120V required)	
Control Panel power wired (Wall Mounted Control cabinet only)	
CORE Appliance solenoid valve wired (Wall Mounted Control cabinet only)	

Fire System Water Inlet - Sprinkler

Refer to the start-up procedure in this manual to complete this section.

Name Plate and Unit Information	
Hood Model Number	
Serial Number	

Field Measured Information	
CORE water line connected to Building Wet Sprinkler System or Dedicated Water supply	
No unsupervised shut-offs in CORE water line	
Verify connection pipe size	
Verify Operating PSI (70 MAX)	
Verify Static Pressure (125 PSI MAX)	
Monitored Pressure Reducing Valve installed	
Verify Field Pipe Material	

Fire System Information (When Supplied)

Refer to the start-up procedure in this manual to complete this section.

Name Plate and Unit Information	
Hood Model Number	
Serial Number	

Field Measured Information	
Gas Valve Wired	
Gas Valve is Functioning Properly	
Main Water Line from Supervised Supply	
Batteries plugged in and light flashes ready	
Verify the supervised loop is run through metallic conduit	
Verify all supervised loop wires are terminated in terminal blocks, junction boxes, and push-stations	
Verify Supervised Loop is not installed with high voltage wiring	
Verify Remote Push Station wired in Supervised Loop	
Test Remote Push Station System Activation	
Verify Push Station Cover Installed	
Verify Firestats are wired in Supervised Loop	
Verify all Firestat wiring is high temperature wire	
Test Firestat System Activation	
Service supervised, assisted or wired all Supervised Loop connections	
Verify Operating Water Pressure (70 MAX)	
Verify Max Static Water Pressure (125 PSI)	
Verify Constant Surfactant Injection	
Verify Appliance System Activates	
All Gas and Electric Appliances Shut Down	
Fire System Activated Light Illuminates	
Audible Alarm Sounds	
Verify Reset Button Works Correctly	
System Activates on Battery Backup	
Verify Surfactant Tank is Full	
Verify Appliance System Test Switch is in Armed Mode	
All Nozzles are 30-55" from Hazard Zone	
Nozzles within 18" from Front/Back of Hazard Zone	
Interior Nozzle facing back opposite end of the appliance (required for Upright Broiler or Salamander)	
Back shelf has overhand of 12" or less	
Back shelf is 18" from the Hazard Zone	
Building Alarm tied in (where applicable)	
Trouble Relay tied in (where applicable)	

Service

Refer to the start-up procedure in this manual to complete this section.

Name Plate and Unit Information	
Hood Model Number	
Serial Number	

Field Measured Information	
Flush lines after all supply lines are connected	
Verify all plenum nozzles have strainers REMOVED	
Document CORE Board Version, not chip version	
Reset Button works	
Fire System activates on Battery backup	
Fire System activate on 120V power	
Audible Alarm Sounds	
Constant surfactant injection during activation	
System reverse interlocked	
Tamper sticker installed on Manual Actuation Device (Push Station)	
Comm module connected to the internet	
CAS-Link Setup	
Battery Date Code (Date of SDV on batteries)	

As a result of our dedication to constant improvements and quality, the MANUFACTURER reserves the right to update specifications without notice. Please refer to MANUFACTURER’S website for up-to-date documentation.

Scan For Online Manual

