

MUA Controls
Standard and Modular/Recirculating Direct Fired Heaters
Installation, Operation, and Maintenance Manual

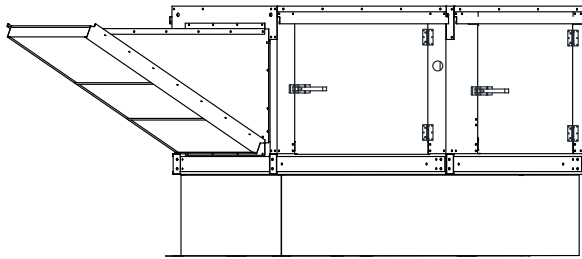

Modular Direct Fired Heater

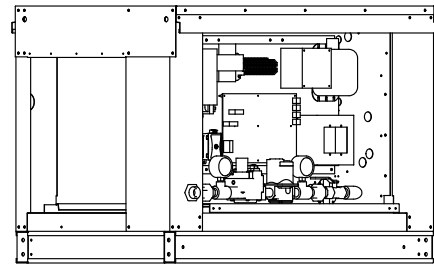

Direct Fired Heater

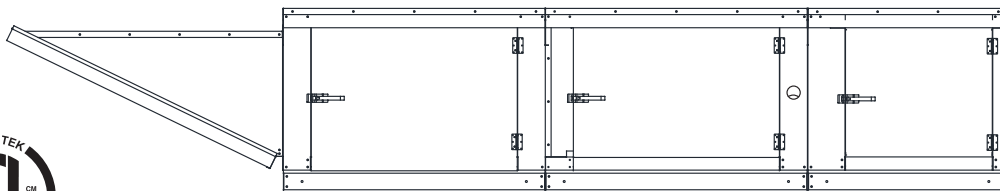

Modular Direct Fired Recirculating Heater

FOR YOUR SAFETY

IF YOU SMELL GAS: OPEN WINDOWS, DO NOT TOUCH ELECTRICAL SWITCHES, EXTINGUISH ANY OPEN FLAMES, IMMEDIATELY CALL YOUR GAS SUPPLIER.

RECEIVING AND INSPECTION

Upon receiving unit, check for any interior and exterior damage. If damage is found, report it immediately to the carrier. Check that all accessory items are accounted for and free of damage.

WARNING!

Improper installation, adjustment, alteration, service, or maintenance can cause property damage, injury, or death. Read the installation, operating, and maintenance instructions thoroughly before installing or servicing this equipment. ALWAYS disconnect power and gas before working on heater.

Save these instructions. This document is the property of the owner of this equipment and is required for future maintenance. Leave this document with the owner when installation or service is complete.

Table of Contents

WARRANTY	4	Modulating Gas System	63
GENERAL INFORMATION	4	High Temperature Limit	63
Patents	4	Pilot Adjustment	63
INSTALLATION	5	Main Burner Adjustment (Maxitrol Valve)	64
Mechanical	5	Main Burner Adjustment (RTC Valve)	65
Site Preparation	5	Final Start-up Procedure	66
Intake/Curb Assembly	7	Airflow Sensor	67
Curb and Ductwork	8	Static Pressure Sensor Installation	68
Roof Mount Installation	10	Component Check/Testing	68
Installation with Exhaust Fan	10	TROUBLESHOOTING	70
Duct Mount Installation	11	Airflow Troubleshooting Chart	70
Indoor (Inline) Installation	11	Burner Troubleshooting	71
Roof Mount Installation - Recirculation Unit	12	HMI Fault Codes	72
Indoor (Inline) Installation Recirculation Unit	12	VFD Fault List	75
Heat Module Add-On Installation	13	Resetting Unit	75
Gas	14	MAINTENANCE	76
Gas Train	15	General Maintenance	76
Electrical	16	2 Weeks After Start-up	76
Fan to Building Wiring Connection	17	Every 3 Months	76
Make-Up Air (MUA) Board Connectors	18	Yearly	76
Duct Static Pressure Control	28	Burner Maintenance	77
Building Static Pressure Control	28	Unit Filters	77
HMI, Space/Wall Sensor, and Room Temp Sensor	29	Emergency Shutdown of Unit	78
HMI (Human Machine Interface)	29	Prolonged Shutdown of Unit	78
Space HMI Control Panel	30	Start-Up Documentation	80
Room Temp Sensor	30	Technical Support Information	80
Temperature Control	31		
Maxitrol Modulating Valve	31		
RTC Modulating Valve	31		
Thermistor	31		
Thermistor Connected to HMI	31		
OPERATION	32		
Accessing Menu Configurations	32		
General Overview	32		
HMI Notification Letters	32		
HMI Configuration Menu	33		
Communication	33		
Advanced Options	33		
Status	33		
About	33		
Scheduling on Unit HMI	34		
Scheduling on Space HMI	34		
Space HMI Menu	35		
Menu Descriptions	36		
Unit Options	51		
Communication Module (Optional)	51		
Building Signal Damper Control	51		
Electric Cabinet Heater	51		
Motorized Intake Damper	51		
Mixing Box Control Unit Options	51		
Variable Frequency Drive (VFD)	52		
Variable Frequency Drive (VFD) Installation	52		
Input AC Power	52		
VFD Output Power	53		
SMV VFD Programming	53		
i500 VFD Programming	54		
VFD Part Number/Specifications	55		
START-UP OPERATION	56		
Unit Start-up Procedure	56		
Pulley Adjustment	57		
Pulley Alignment/Proper Belt Tension	58		
Pulley Combination Chart	59		
Components	60		
Sequence of Operation	61		
Flame Safety Control	61		

WARRANTY

This equipment is warranted to be free from defects in materials and workmanship, under normal use and service, for a period of 2-years from date of shipment. This warranty shall not apply if:

1. The equipment is not installed by a qualified installer per the MANUFACTURER'S installation instructions shipped with the product.
2. The equipment is not installed in accordance with Federal, State, and Local codes and regulations.
3. The equipment is misused, neglected, or not maintained per the MANUFACTURER'S maintenance instructions.
4. The equipment is not installed and operated within the limitations set forth in this manual.
5. The invoice is not paid within the terms of the sales agreement.

The MANUFACTURER shall not be liable for incidental and consequential losses and damages potentially attributable to malfunctioning equipment. Should any part of the equipment prove to be defective in material or workmanship within the 2-year warranty period, upon examination by the MANUFACTURER, such part will be repaired or replaced by MANUFACTURER at no charge. The BUYER shall pay all labor costs incurred in connection with such repair or replacement. Equipment shall not be returned without MANUFACTURER'S prior authorization, and all returned equipment shall be shipped by the BUYER, freight prepaid to a destination determined by the MANUFACTURER.

For questions about installation, warranty, or service, go to support.captiveaire.com or “**Technical Support Information**” on page 80 for more information.

GENERAL INFORMATION

Listing

This unit is ETL-listed to the American National Standard/CSA Standard for Gas Unit Heaters And Gas-Fired Duct Furnaces ANSI Z83.4, CSA 3.7.

The Safety Control Board is ETL-listed to standard UL 60730-2-9, UL 60730-1, CSA E60730-1, CSA E60730-2-9.

Patents

This product may be covered by one or more of the following patent number(s): (United States) 6629523, or other U.S. and foreign patents pending.

INSTALLATION

It is imperative that this unit is installed and operated with the designed airflow and electrical supply in accordance with this manual. For questions about installation, warranty, or service, go to support.captiveaire.com or “**Technical Support Information**” on page 80 for more information.

Mechanical

WARNING: DO NOT RAISE UNIT BY THE INTAKE HOOD, BLOWER, MOTOR SHAFT, OR BEARINGS. USE ALL LIFTING LUGS PROVIDED WITH A SPREADER BAR OR SLING UNDER THE UNIT.

Clearance

The top, back, and front surfaces of this heater may not be installed less than 6” from combustible materials. The heater base may be installed on combustible surfaces. Allow 24” minimum service clearance on both sides of this heater.

Site Preparation

1. Provide clearance around installation site to safely rig and lift equipment into its final position (**Figure 1**). Supports must adequately support equipment. Refer to manufacturer’s estimated weights.
2. Locate unit close to the space it will serve to reduce long, twisted duct runs.
3. Consider general service and installation space when locating unit.
4. Do not allow air intake to face prevailing winds. Support unit above ground or at roof level high enough to prevent precipitation from being drawn into its inlet. The inlet must also be located at least 10 feet away from any exhaust vents. The fan inlet shall be located in accordance with the applicable building code provisions for ventilation air.
5. All air to the heater must be ducted from the outdoors. Recirculation of room air is not permitted. If in doubt regarding the application, consult the manufacturer.
6. Recirculation of room air may be hazardous in the presence of:
 - Flammable solids, liquids, and gases
 - Explosive materials (e.g., grain dust, coal dust, gunpowder, etc.)
 - Substances which may become toxic when exposed to heat (e.g., refrigerants, aerosols, etc.)
7. Recirculation is not recommended in uninsulated buildings where outside temperatures fall below 32°F (0°C).
8. Excessive recirculation or insufficient ventilation air, which results in inadequate dilution of the combustion products generated by the heater, may create hazardous concentrations of carbon dioxide, carbon monoxide, nitrogen dioxide, and other combustion products in the heated space. Refer to **Table 1 on page 6** for ventilation requirements.

Figure 1 - Spreader Bar

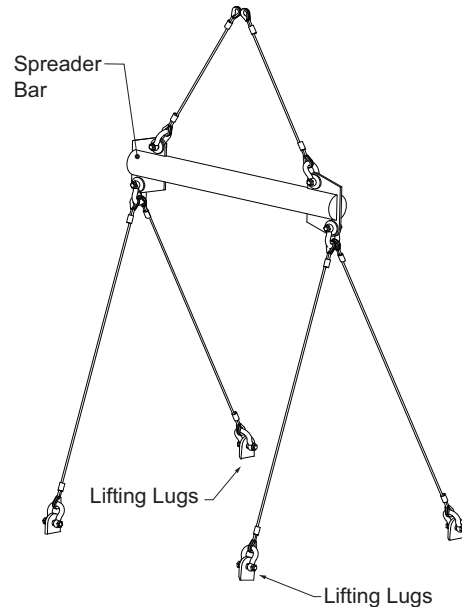

9. If gas fork trucks or other fossil fuel powered equipment are utilized in the conditioned area, additional ventilation requirements for the facility must be addressed separately.
10. If the heater utilizes room sensors for limiting room CO₂ concentration:
 - The CO₂ control set-point shall be no greater than the maximum allowable room concentration of 5000 ppm less the sensor's published accuracy tolerance. The control shall prevent the CO₂ concentration in room air from exceeding 5000 ppm.
 - A minimum of one sensor shall be installed per room served by the heater.
 - When a room area, served by a single heater, does not exceed 10,000 ft² (929 m²) and height does not exceed 20 ft. (6 m), a duct sensor may be installed in the return air opening of the heater.
 - Sensors shall be calibrated per the sensor manufacturer's recommended procedure and frequency or annually, whichever is more frequent.
 - Each heater shall require CO₂ sensor(s).
 - Sensors shall not be placed near sources of CO₂.

Table 1 - Minimum Ventilation Requirements for Heaters that Recirculate

Minimum Ventilation Rate (as % of Total Air Throughput)									
%	5	10	15	20	25	30	40	50	60
Maximum Equivalent Temp. Rise Through Heat for CO ₂ °F (°C)									
Natural Gas	12.2 (6.8)	24.5 (13.6)	36.7 (20.4)	49.0 (27.2)	61.2 (34.0)	73.5 (40.8)	98.0 (54.4)	122.5 (68.0)	146.9 (81.6)
Propane Gas	10.6 (5.9)	21.1 (11.7)	31.7 (17.6)	42.2 (23.5)	52.8 (29.3)	63.4 (35.2)	84.5 (46.9)	105.6 (58.7)	126.7 (70.4)

Intake/Curb Assembly

Intakes and curbs (**Figure 2**) are shipped on a separate skid. Upon unit arrival, perform the following steps to assemble the unit.

1. Apply weatherproof gasketing to the curb. Apply silicone or weather-proof gasketing to the backside of the flanges on the intake hood or V-bank intake.
2. Secure the flanges of the intake hood to the unit with the supplied sheet metal screws.
3. Use caulk on the outside of the screws to prevent water leaks.
4. If the unit is a modular unit with a V-bank or evaporative cooler section, the V-bank or evaporative cooler will bolt to the heater with the bolts provided.
5. Slide the filters down the filter track.

Figure 2 - Intake and Curb Assembly

Direct Fired

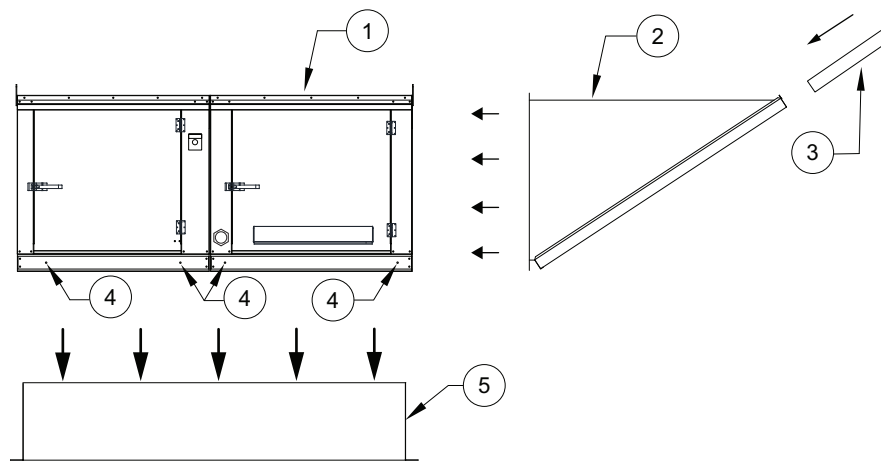

Direct Fired Recirc

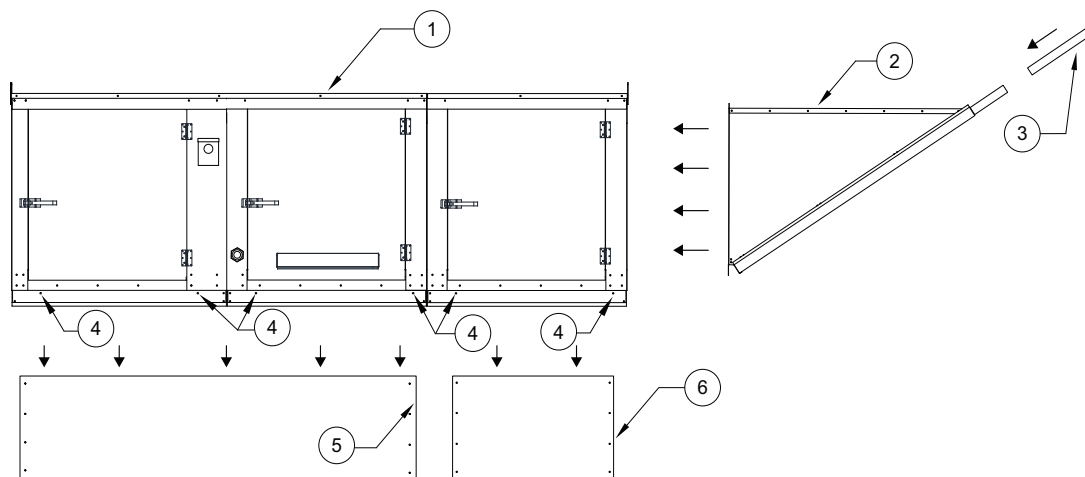

- | | |
|---------------------|--------------------------------------------|
| 1. Unit | 4. Unit to Curb Hardware Mounting Location |
| 2. Intake Housing | 5. Curb |
| 3. Intake Filter(s) | 6. Mixing Box Curb |

Curb and Ductwork

This fan was specified for a specific CFM and static pressure. The ductwork attached to this unit will significantly affect airflow performance. When using rectangular ductwork, elbows should be radius throat, radius back with turning vanes. Flexible ductwork and square elbows should not be used. Any transitions and/or turns in the ductwork near the fan outlet will cause system effect. System effect will drastically increase the static pressure and reduce airflow.

- **Table 3 on page 9** displays the minimum fan outlet duct sizes and straight lengths recommended by the manufacturer for optimal fan performance. **Table 2** displays recommended return ductwork sizes for recirculating units. Failure to adhere to recommendations may cause performance issues and/or structural damage. Any unit damage caused by not adhering to recommended duct lengths will not be covered under warranty.
- Do not use the unit to support ductwork in any way. This may cause damage to the unit.
- **Follow SMACNA guides and manufacturer's requirements for the remaining duct run.** Fans designed for rooftop installation should be installed on a prefabricated or factory-built roof curb.
- Follow curb manufacturer's instructions for proper curb installation.
- The unit should be installed on a curb and/or rail that meets local code height requirements.
- Make sure the duct connection and fan outlet are properly aligned and sealed.
- Secure fan to curb through vertical portion of the ventilator base assembly flange. Use a minimum of eight (8) lug screws, anchor bolts, or other suitable fasteners (not furnished). Shims may be required depending upon curb installation and roofing material.
- Verify all fasteners are secure. **Figure 3** through **Figure 8** show different mechanical installations.
- Adequate building relief shall be provided so as not to over pressurize the building when the heating system is operating at its rated capacity. This can be accomplished by taking into account, through standard engineering methods, the structure's designed infiltration rate; by providing properly-sized relief openings; or by interlocking a powered exhaust system; or by a combination of these methods.
- Heaters installed with intake ductwork must be purged to replace at least four air changes of the volume of the intake duct.
- If the failure or malfunction of this heater creates a hazard to other fuel-burning equipment in the building (e.g., when the heater is providing makeup air to a boiler room), the unit is to be interlocked to open inlet air dampers or other such devices.
- On outdoor installations, it is recommended that the discharge duct be insulated to prevent condensation during the "OFF" cycle in cold weather.
- Flexible connectors should be used on all ductwork connections. Vibration isolators are optional and can be supplied in the loose parts package.
- Units that are installed in airplane hangars should be installed in accordance with the Standard for Aircraft Hangars, ANSI/NFPA 409. Units that are to be installed in public garages should be installed in accordance with the Standard for Parking Structures, ANSI/NFPA 88A, or the Standard for Repair Garages, ANSI/NFPA 88B, and with CAN/CGA B149 Installation Codes.

Table 2 - Recommended Return Ductwork Sizes

Mixing Box	Duct Size (Inches)
1	19 x 15
2	25 x 24
3	31 x 29
4	37 x 34
5	44 x 44

Table 3 - Supply Ductwork Sizing

Blower Size (Inches)	Discharge	Duct Size	Straight Duct Length
10	Side	14" x 14"	46"
	Up/Down		
15D, 16Z, 18Z	Side	20" x 20"	66"
	Up/Down	14" x 14"	46"
12	Side	16" x 16"	53"
	Up/Down		
15	Side	20" x 20"	66"
	Up/Down		
20D, 20Z, 22Z	Side	26" x 26"	86"
	Up/Down	20" x 20"	66"
18	Side	24" x 24"	79"
	Up/Down		
24D, 25Z	Side	30" x 30"	99"
	Up/Down	24" x 24"	79"
20	Side	26" x 26"	86"
	Up/Down		
30D, 28Z	Side	32" x 32"	105"
	Up/Down	26" x 26"	86"
25	Side	32" x 32"	105"
	Up/Down		
36D	Side	36" x 36"	119"
	Up/Down	32" x 32"	105"

WARNING!

Failure to properly size ductwork may cause system effects and reduce the performance of the equipment. Refer to "Curb and Ductwork" on page 8 for installation guidelines.

Roof Mount Installation

Note: Refer to submittal drawings for specific unit dimensions.

Figure 3 - Roof Mount Details

1. Discharge Opening
2. Curb Outer Wall
3. Flex Conduit Located in Curb Area for Field Wiring
4. Intake Housing
5. Lifting Lugs
6. Direct Fired Module
7. Service Disconnect Switch
8. Blower/Motor Access Door
9. Curb
10. Control Drop
11. Motor Drop
12. Unit to Curb Hardware Mounting Location
13. Gas Connection

Max. Roof Opening 2" Smaller than Curb Outside Dimension.

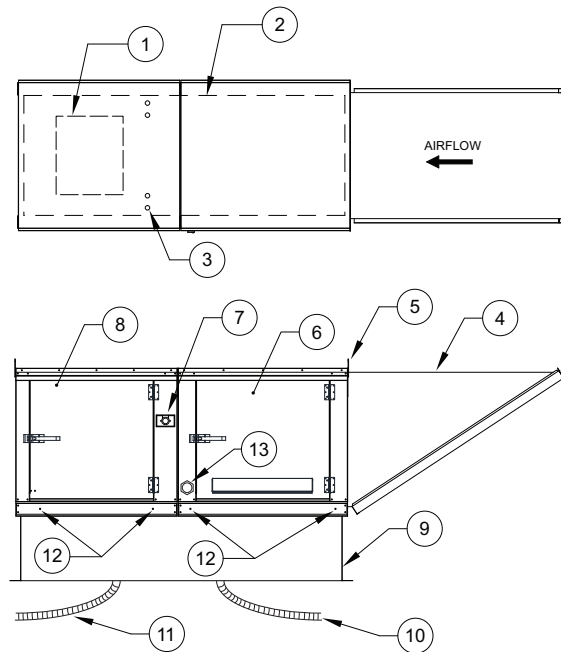

Installation with Exhaust Fan

Note: Refer to submittal drawings for specific unit dimensions.

Figure 4 - Exhaust Fan Details

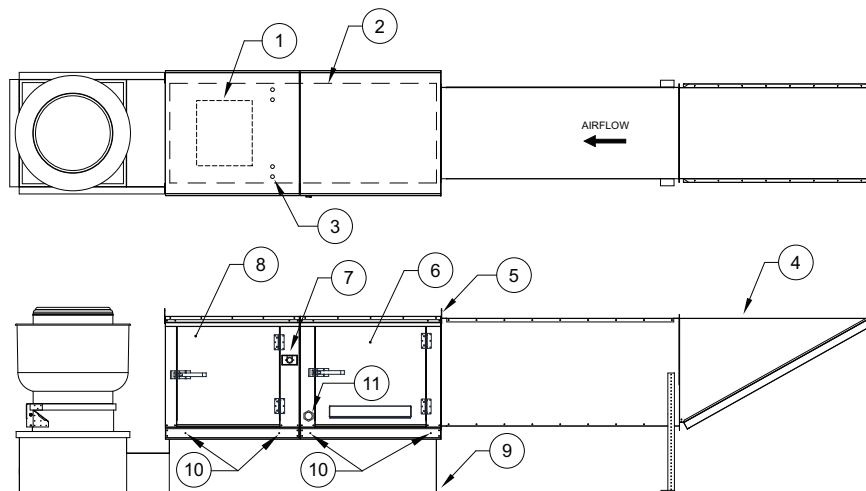

- | | | |
|-------------------------------------------------------|------------------------------|---------------------------------------------|
| 1. Discharge Opening | 5. Lifting Lugs | 9. Curb with Support Legs or Rail |
| 2. Curb Outer Wall | 6. Direct Fired Module | 10. Unit to Curb Hardware Mounting Location |
| 3. Flex Conduit Located in Curb Area for Field Wiring | 7. Service Disconnect Switch | 11. Gas Connection |
| 4. Intake Housing | 8. Blower/Motor Access Door | |

Max. Roof Opening 2" Smaller than Curb Outside Dimension.

Duct Mount Installation

Note: Refer to submittal drawings for specific unit dimensions.

Figure 5 - Duct Mount Details

1. Control/Valve Access Door
2. Gas Connection
3. Optional Unistrut Base
4. Lifting Lugs

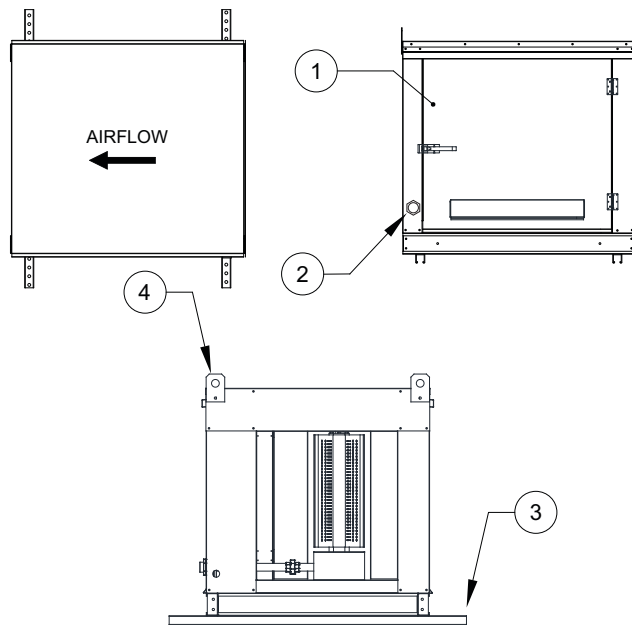

Indoor (Inline) Installation

Note: Refer to submittal drawings for specific unit dimensions.

Figure 6 - Indoor Installation Details

1. Flex Conduit for Field Wiring
2. Optional Unistrut Base
3. Lifting Lugs
4. Control/Filter Access Door
5. Control/Valve Access Door
6. Gas Connection
7. Blower/Motor Access Door
8. Service Disconnect Switch

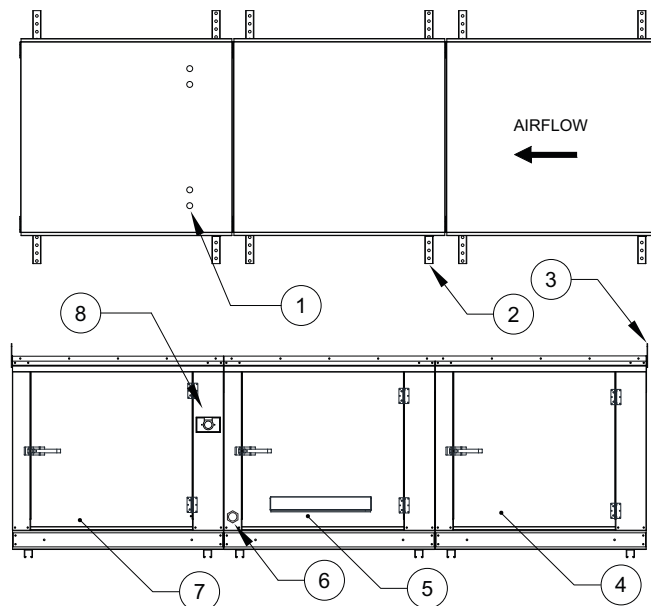

Roof Mount Installation - Recirculation Unit

Note: Refer to submittal drawings for specific unit dimensions.

Figure 7 - Roof Mount Details

1. Discharge Opening
2. Curb(s) Outer Wall
3. Return Damper
4. Flex Conduit for Field Wiring
5. Blower/Motor Access Door
6. Service Disconnect Switch
7. Direct Fired Module
8. Optional Filters
9. Intake Damper
10. Lifting Lugs
11. Intake Filter
12. Control Drop
13. Motor Drop
14. Unit to Curb Hardware Mounting Location
15. Gas Connection

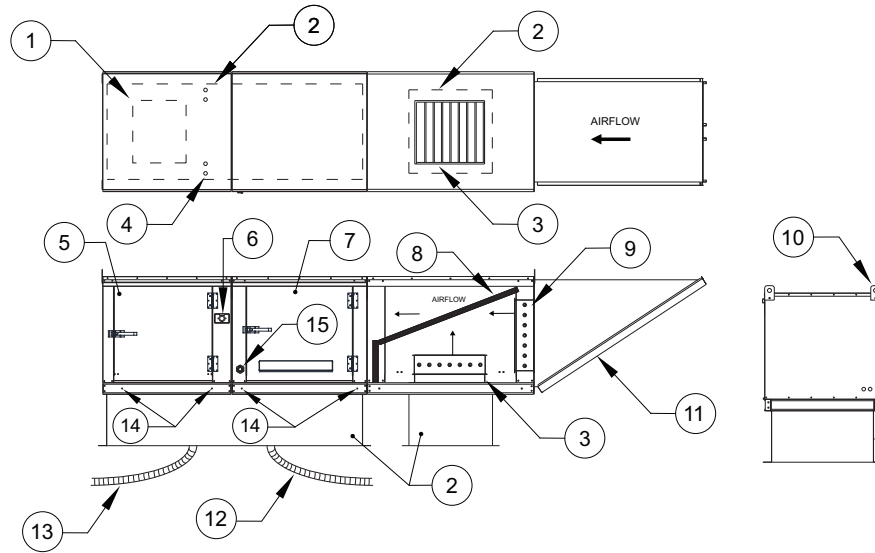

Indoor (Inline) Installation Recirculation Unit

Note: Refer to submittal drawings for specific unit dimensions.

Figure 8 - Indoor Installation Details

1. Flex Conduit for Field Wiring
2. Optional Filters
3. Return Damper
4. Intake Damper
5. Direct Fired Module
6. Blower/Motor Access Door
7. Service Disconnect Switch
8. Lifting Lugs
9. Optional Uni-Strut Base

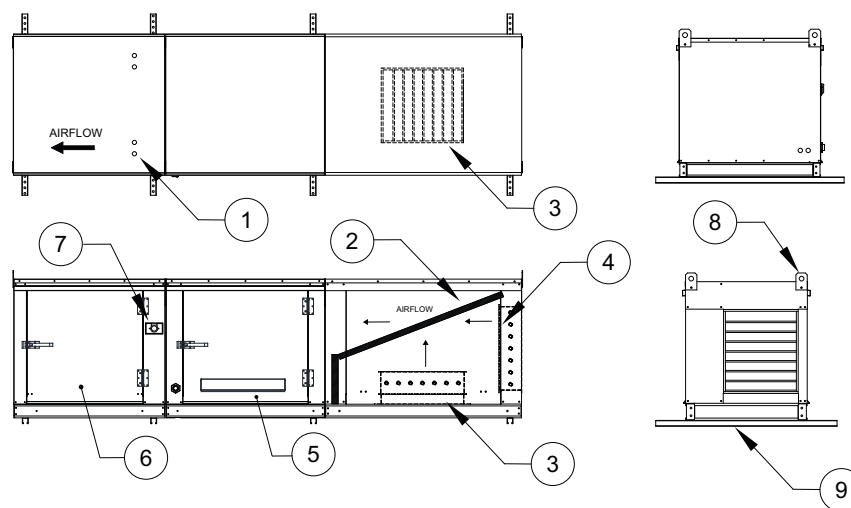

Heat Module Add-On Installation

Modular heat units (**Figure 9**) that are ordered to provide heat onto an existing blower only application require field mechanical and wiring installation.

1. Remove existing intake housing and lifting lugs from the blower section intake side.
2. Attach heat module to blower intake using the provided sheet metal screws and bolts. Tighten screws and bolts to compress the gasket between the heat module and the blower module.
3. Support and level the end of the heat module (opposite end of the blower) with the provided equipment legs/rails.
4. Attach the intake housing to the intake side of the heater module.
5. Drill a hole in the discharge of the blower large enough to insert the discharge control sensor (if provided). Install the sensor through the hole.
6. Wire the sensor and coil as indicated on the supplied wiring schematic. Route all wiring through metal conduit.
7. After the add-on installation is complete, refer to “**Unit Start-up Procedure**” on page 56.

Figure 9 - Heat Module

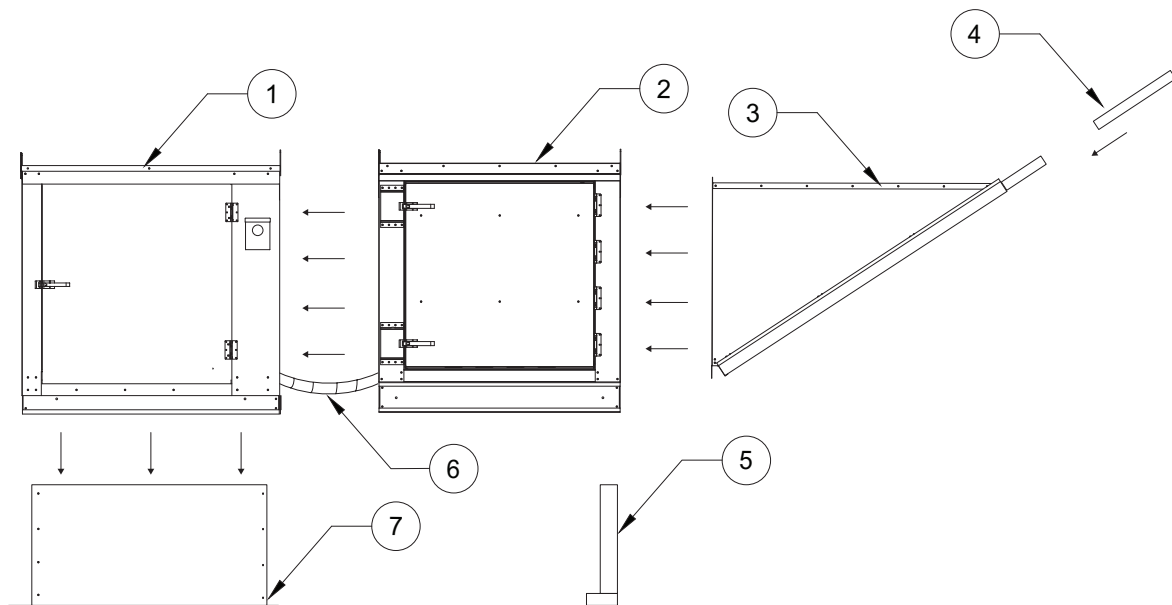

- | | |
|------------------------|-------------------|
| 1. Blower | 5. Equipment Legs |
| 2. Direct Fired Module | 6. Conduit |
| 3. Intake Housing | 7. Curb |
| 4. Filters | |

Gas

Installation of gas piping must conform with local building codes, or in the absence of local codes to the National Fuel Gas Code, ANSI Z223.1 (NFPA 54) – latest edition. In Canada, installation must be in accordance with CAN/CGA-B149.1 for natural gas units and CAN/CGA-B149.2 for propane units.

WARNING: INLET GAS PRESSURE MUST NOT EXCEED PRESSURE INDICATED ON NAMEPLATE. SEE UNIT NAMEPLATE FOR PROPER GAS SUPPLY PRESSURE AND GAS TYPE.

1. Always **disconnect power** before working on or near a heater. Lock and tag the disconnect switch or breaker to prevent accidental power-up.
2. Piping to the unit should conform to local and national requirements for type and volume of gas handled, and pressure drop allowed in the line. Refer to the Gas Engineer's Handbook for gas line capacities.
3. The incoming pipe near the heater should be sized to match the connection on the outside of the unit. Unit inlet sizes are shown in **Table 4 on page 15**. The unit requires a steady supply of gas at all times, avoid multiple taps in the gas supply line.
4. Install a ground joint union with brass seat and a manual shut-off valve external to the unit casing. Install shut-off valve adjacent to the unit for emergency shut-off and easy servicing of controls. Refer to **Figure 10 on page 15**.
5. Provide a sediment trap, as shown in **Figure 10**, before each unit and where low spots in the pipeline cannot be avoided.
6. Clean out the gas line to remove debris before making connections. Purge gas line to remove air before attempting to start unit. Purging air from gas lines should be performed as described in ANSI Z223.1-latest edition "National Fuel Gas Code," or in Canada as described in CAN/CGA-B149.
7. All field gas piping must be pressure/leak tested before unit operation. Use a non-corrosive bubble forming solution or equivalent for leak testing. The heater and its individual shut-off valve must be disconnected from the gas supply piping system during any pressure testing of that system at test pressures in excess of 1/2 psi.
8. This unit requires the gas pressure to be within the unit's minimum and maximum gas pressure ratings. If the pressure is greater than the maximum, the internal valve components will be damaged. If the pressure is below the minimum, the heater will not perform to specifications. Refer to **Table 4 on page 15** for gas pressure ratings.

NOTICE

Refer to the heater's rating plate for determining gas supply pressures and requirements.

Gas Train

A strainer must be installed to prevent debris from entering the gas train. Only use new piping. Properly ream and clean metal burrs. Proper care is needed to ensure that the gas flow is in the same direction as indicated on the strainer. Do not over-tighten pipe connections. Use pipe dope on male threads only. Install a drip leg in the gas line in accordance with the Authority Having Jurisdiction (AHJ) guidelines.

Figure 10 - Gas Connection Diagram

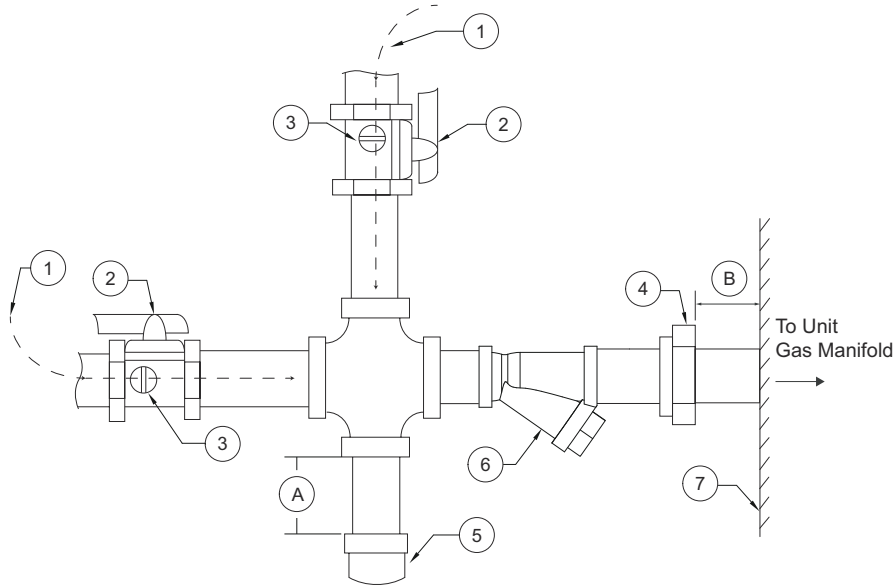

- | | |
|-------------------------------------------|-------------------------|
| 1. Gas Supply Line Connection | 6. Strainer |
| 2. Manual Gas Shut-off Valve | 7. Unit |
| 3. Plugged 1/8" NPT Test Gauge Connection | A. Minimum Depth = 6" |
| 4. Ground Joint Union with Brass Seat | B. Maximum Length = 12" |
| 5. Sediment Trap | |

Proper clearance must be provided in order to service the strainer. A minimum of a 4" clearance distance must be provided at the base of the strainer.

Table 4 - Gas Train Details

Pressure Type	Gas Pressure
Size 1-3 Inlet Pressure	7 - 14 Inches WC
Size 4-5 Inlet Pressure	7 Inches WC - 5 psi
Maximum Manifold Pressure - Propane (LP)	2.5 Inches WC Maximum
Maximum Manifold Pressure - Natural Gas	5 Inches WC Maximum
Strainer	Size
Size 1 = 4417K64	3/4"
Size 2 and Size 3 = 4417K65	1"
Size 4 = 4417K66	1-1/4"
Size 5 = 4417K67	1-1/2"

Electrical

WARNING!

Disconnect power before installing or servicing unit. High voltage electrical input is needed for this equipment. A qualified electrician should perform this work.

Before connecting power to the heater, read and understand the entire section of this document. As-built wiring diagrams are furnished with each unit by the factory. The diagrams are attached to the control module's door or provided with paperwork packet.

Electrical wiring (**Table 5**) and connections must be made in accordance with local ordinances and the National Electric Code, ANSI/NFPA 70. Verify the voltage and phase of the power supply, and the wire amperage capacity is in accordance with the unit nameplate. For additional safety information, refer to AMCA publication 410-96, *Recommended Safety Practices for Users and Installers of Industrial and Commercial Fans*.

1. **Always disconnect power before working on or near this equipment. Lock and tag the disconnect switch and/or breaker to prevent accidental power-up.**
2. An electrical drop containing the line voltage power wiring is shipped with every unit. The electrical drop should be brought through one of the conduit openings located in the base of the unit (**Figure 3 on page 10**), run through the curb, and connected to a junction box inside the building.
3. A dedicated branch circuit should supply the motor circuit with short circuit protection according to the National Electric Code. This dedicated branch should run to the junction box.
4. Verify that the power source is compatible with the requirements of your equipment. The nameplate identifies the **proper phase and voltage** of the equipment.
5. Units shipped with a remote HMI will require a second drop through the base of the unit. It is important to route the motor wires in a separate conduit from the HMI wiring. Refer to **Figure 3 (Direct Fired)/Figure 7 (Recirc) on page 12**.
6. Before connecting the unit to the building's power source, verify that the power source wiring is de-energized. Refer to **"Fan to Building Wiring Connection" on page 17**.
7. Secure the power cable to prevent contact with sharp objects. Verify ground connection is secured.
8. Do not kink power cable and never allow the cable to encounter oil, grease, hot surfaces, or chemicals.
9. Before powering up the unit, that the fan rotates freely. Make sure that the interior of the unit is free of loose debris or shipping materials.
10. Electrically Commutated Motors (ECMs) and Variable Frequency Drives (VFDs) should not be powered through a Ground Fault Circuit Interrupter (GFCI) breaker/outlet. Unnecessary and intermittent tripping may occur.
11. If any of the original wire supplied with the unit must be replaced, it must be replaced with type THHN wire or equivalent.

Table 5 - Copper Wire Ampacity

Wire Size AWG	Maximum Amps
14	15
12	20
10	30
8	50
6	65
4	85
3	100
2	115
1	130

Fan to Building Wiring Connection

Figure 11 - Wiring Connection Details

Single Point Connection

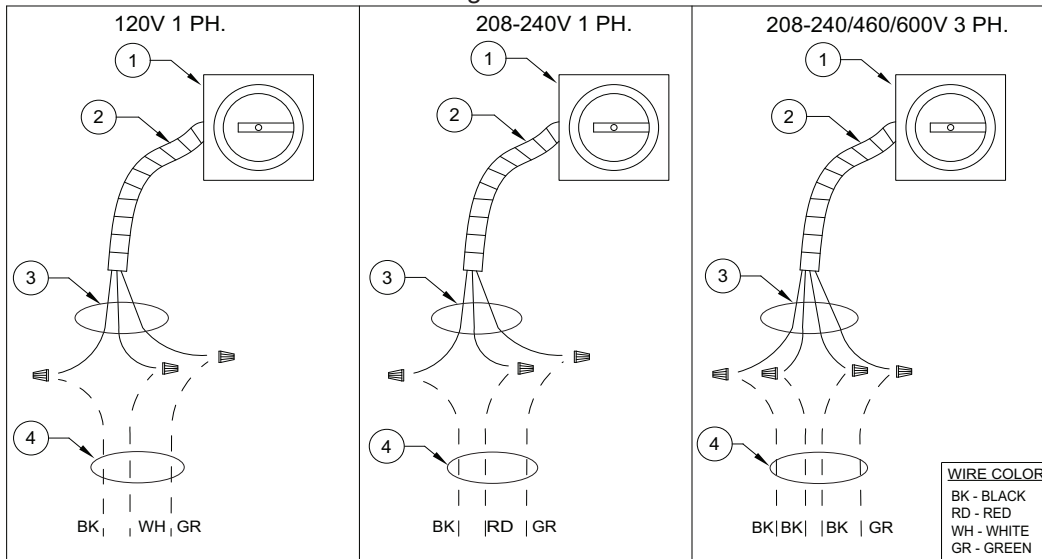

1. Disconnect Switch
2. Galflex Conduit (In Unit)
3. Factory Wiring
4. Field Supplied Wiring - From building power or pre-wired control panel.

120V Optional

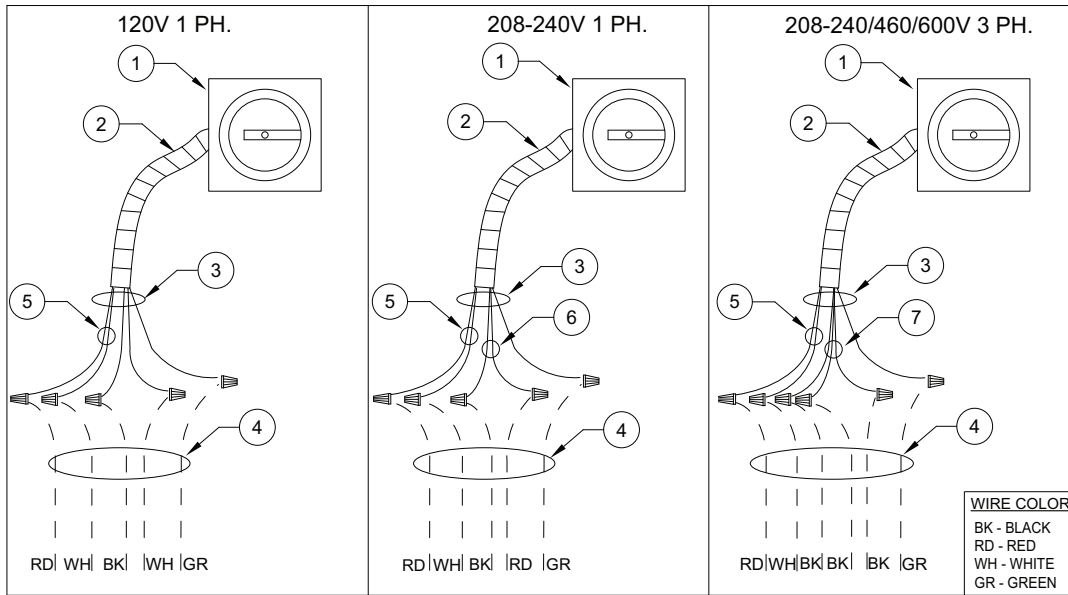

1. Disconnect Switch
2. Galflex Conduit (In Unit)
3. Factory Wiring
4. Field Supplied Wiring - From building power or pre-wired control panel.
5. 120V Single Phase Standing Power
6. 208-240 Single Phase
7. Three Phase

Make-Up Air (MUA) Board Connectors

The Make-up Air (MUA) Board (Figure 12) is located in the main control cabinet.

Figure 12 - Make-Up Air Board

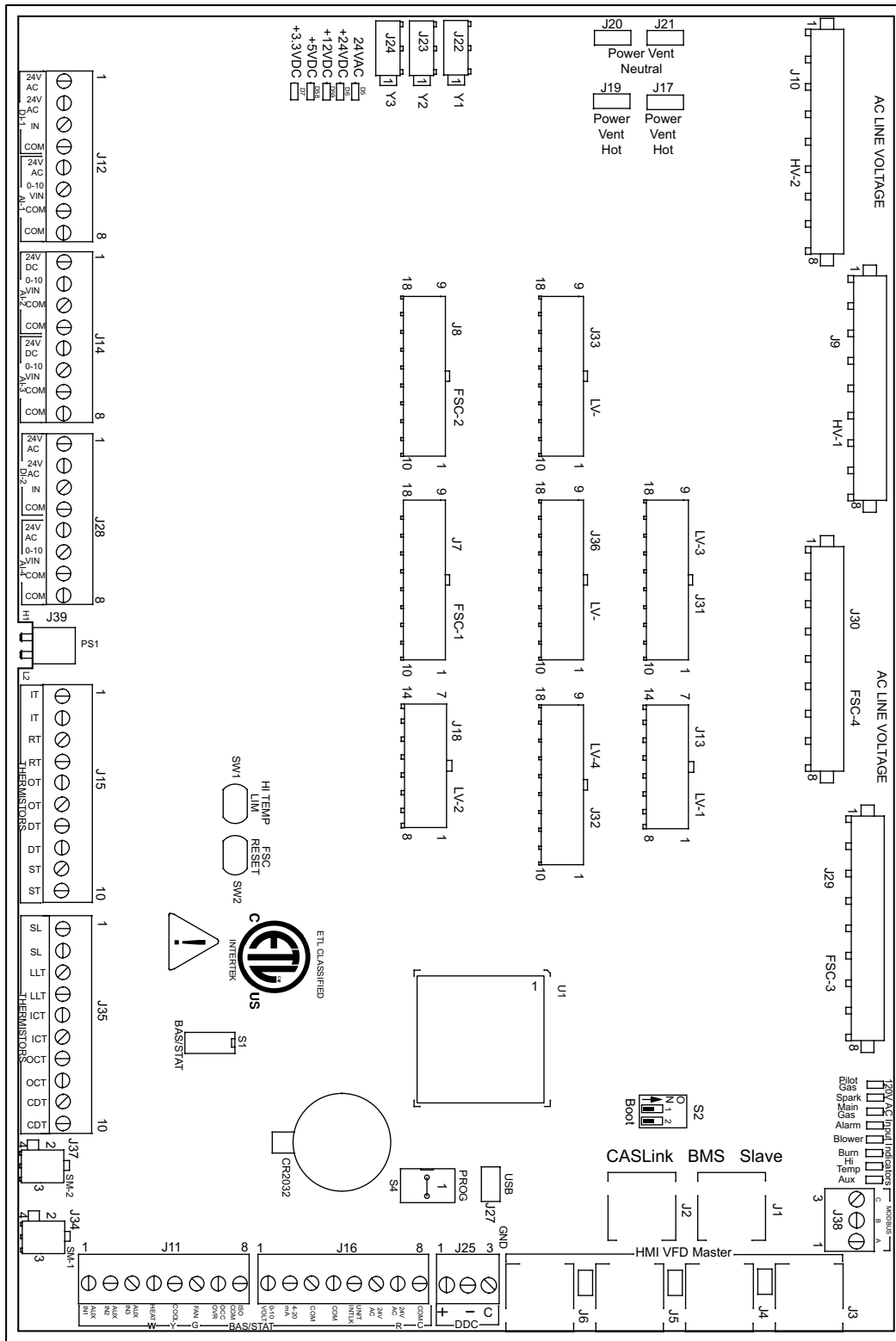

Note: Some connections may not be used dependent on system configurations.

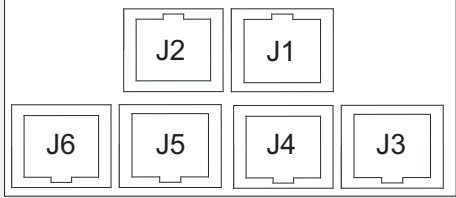
<p>RJ45 connectors. Connector J1 and J2 are associated with BMS. Connector J3 through J6 are interchangeable and may be used to connect to an HMI or VFD.</p>	
<p>J1 - CASLink/Slave J2 - CASLink/Slave J3 - HMI/VFD/Master</p>	<p>J4 - HMI/VFD/Master J5 - HMI/VFD/Master J6 - HMI/VFD/Master</p>

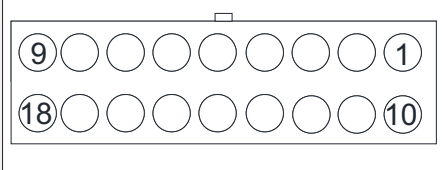
<p>Connector J7 contains inputs and outputs for the Flame Safety Controller (FSC)</p>	
<p>Pin 1 - 24VAC Main Gas Valve Pin 2 - 24VAC Pilot Valve Pin 3, Pin 4, Pin 5 - N/A Pin 6 - 0-10VDC+ Analog Output to Modulating Gas Valve</p>	<p>Pin 7 - 0-10VDC (-) Analog Output to Modulating Gas Valve Pin 8 - N/A Pin 9 - 24VAC Common to Main/Pilot Gas Valve Pin 10 - 24VAC Input from BP Pin 11 through Pin 18 - N/A</p>

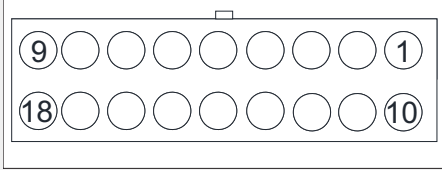
<p>Connector J8 contains inputs and outputs for the Flame Safety Controller (FSC) NOTE: Connector J8 only for Compact Models</p>	
<p>Pin 1 - N/A Pin 2 - 24VAC Pilot Valve Pin 3 through Pin 8 - N/A</p>	<p>Pin 9 - 24VAC Common to Main/Pilot Gas Valve Pin 10 through Pin 18 - N/A</p>

<p>Connector J9 contains 120V AC connections</p>	
<p>Pin 1 - 120VAC Main Input Pin 2 - 120VAC Input from Discharge Damper End Switch Pin 3 - 120VAC Input from Fire Micro-Switch Pin 4 - 120VAC Output to Intake/Discharge Damper Actuator</p>	<p>Pin 5 - 120VAC Input from Intake Damper End Switch Pin 6 - N/A Pin 7 - 120VAC Output to Cabinet Heater Pin 8 - 120VAC Neutral</p>

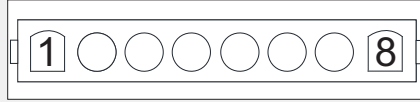
<p>Connector J10 contains 120V AC connections</p>	
<p>Pin 1 - 120VAC Input from Evap Cooler Pressure Switch Pin 2 - 120VAC Input from Evap Cooler Float Switch Pin 3 - 120VAC Output to Evap Cooler Water Solenoid Pin 4 - 120VAC Output to Evap Cooler 3-way Drain Valve</p>	<p>Pin 5 - 120VAC Input from Supply Overload Switch Pin 6 - 120VAC Output to Supply Starter Coil Pin 7 - 120VAC Output to Exhaust Starter Coil Pin 8 - 120VAC Input from Exhaust Overload</p>

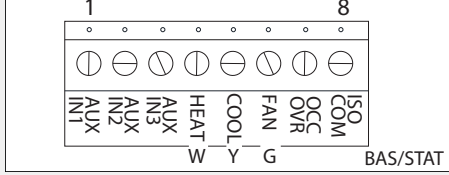
<p>Connector J11 contains low voltage screw terminal connections</p>	
<p>Pin 1 - 24VAC Auxiliary Input/Purge Mode Pin 2 - 24VAC Auxiliary Input Pin 3 - 24VAC Auxiliary Input Pin 4 - 24VAC Call for Heat Input/Burner Interlock</p>	<p>Pin 5 - 24VAC Call for Cooling Input/AC Interlock Pin 6 - 24VAC Call for Blower Input Pin 7 - 24VAC Occupied Override Input Pin 8 - 24VAC Isolated Common</p>

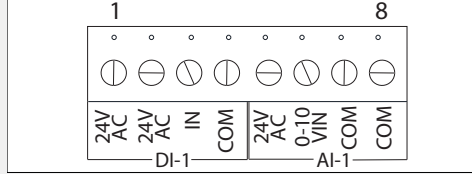
<p>Connector J12 contains low voltage screw terminal connections</p>	
<p>Pin 1 - 24VAC Output to Smoke Detector Pin 2 - 24VAC Output to Smoke Detector Pin 3 - 24VAC Digital Input from Smoke Detector Pin 4 - 24VAC Common to Smoke Detector</p>	<p>Pin 5 - 24VAC Output to Air Quality Sensor Pin 6 - 0-10V Analog Input from Air Quality Sensor Pin 7 - 24VAC Common to Air Quality Sensor Pin 8 - 24VAC Common to Air Quality Sensor</p>

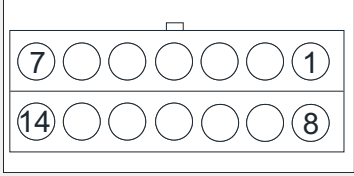
<p>Connector J13 contains low voltage connections</p>	
<p>Pin 1 - N/A Pin 2 - PWM + Output for Supply ECM Pin 3 - 24VAC Output for Low Gas Pressure Switch Pin 4 - 24VAC Output for High Gas Pressure Switch Pin 5 - 24VAC Output for Clogged Filter Switch Pin 6 - 24VAC Output for Low Airflow Pin 7 - 24VAC Input for Board Power</p>	<p>Pin 8 - N/A Pin 9 - PWM Output for Supply ECM Pin 10 - 24VAC Input from Low Gas Pressure Switch Pin 11 - 24VAC Input from High Gas Pressure Switch Pin 12 - 24VAC Input from Clogged Filter Switch Pin 13 - 24VAC Input from Low Air Pressure Switch Pin 14 - 24VAC for Board Power</p>

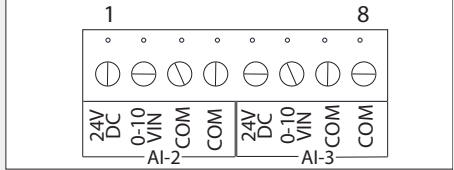
<p>Connector J14 contains screw terminal connections</p>	
<p>Pin 1 - 24VAC Output to Humidity Sensor Pin 2 - 0-10VDC Analog Input from Humidity Sensor Pin 3 - 24VAC Common to Humidity Sensor Pin 4 - 24VAC Common to Humidity Sensor</p>	<p>Pin 5 - 24VAC Output to Humidity Sensor Pin 6 - 0-10VDC Analog Input Humidity Sensor Pin 7 - 24VAC Common Humidity Sensor Pin 8 - 24VAC Common to Humidity Sensor</p>

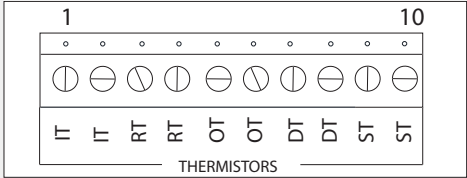
<p>Connector J15 contains low voltage connections</p>	
<p>Pin 1 - Intake Temperature Thermistor Input Pin 2 - Intake Temperature Thermistor Input Pin 3 - Return Temperature Thermistor Input Pin 4 - Return Temperature Thermistor Input Pin 5 - Outdoor Temperature Thermistor Input</p>	<p>Pin 6 - Outdoor Temperature Thermistor Input Pin 7 - Discharge Temperature Thermistor Input Pin 8 - Discharge Temperature Thermistor Input Pin 9 - Space Temperature Thermistor Input Pin 10 - Space Temperature Thermistor Input</p>

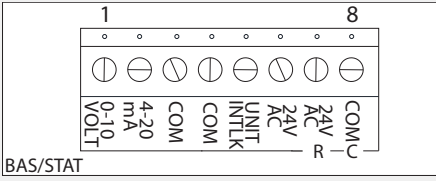
<p>Connector J16 contains low voltage screw terminal connections</p>	
<p>Pin 1 - 0-10VDC Analog Input for Heat Modulation/ Pressure Sensor Pin 2 - 4-20 mA Analog Input for Heat Modulation/ Pressure Sensor Pin 3 - 24VAC Common Pin 4 - 24VAC Common</p>	<p>Pin 5 - 24VAC Unit Interlock Input Pin 6 - 24VAC Output (Stat) Pin 7 - 24VAC Output (R) Pin 8 - 24VAC Common</p>

NOTE: Connector J17 is grouped with connectors J-19 through J-21

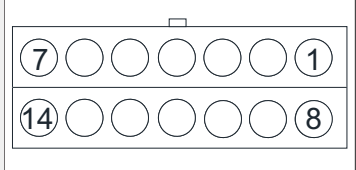
<p>Connector J18 contains low voltage connections</p>	
<p>Pin 1 - 24VDC + Output Pin 2 - 0-10VDC Analog Output for Mixing Box Actuator Pin 3 - 0-10VDC Analog Output for Bypass Damper Pin 4 - 24VAC Output for DX Float Switch Pin 5 - 24VAC Output for Door Interlock Pin 6 - 24VAC Warm Liquid Bypass Output Pin 7 - 24VAC for Damper Actuator</p>	<p>Pin 8 - 24VDC - Common Pin 9 - Common for Mixing Box Actuator Pin 10 - Common for Bypass Damper Pin 11 - 24VAC Input from DX Float Switch Pin 12 - 24VAC Input from Door Interlock Pin 13 - 24VAC Warm Liquid Bypass Output Common Pin 14 - 24VAC for Damper Actuator</p>

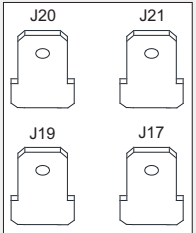
<p>Connector J17 - N/A Connector J19 - N/A Connector J20 - N/A Connector J21 - N/A</p>	
-----------------------------------------------------------------------------------------------------------------------------------	---------------------------------------------------------------------------------------

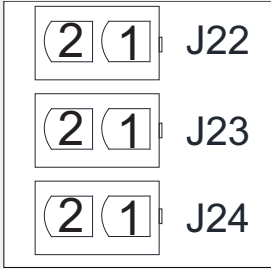
<p>Connector J22 (Y1) Condenser 1 Connector J23 (Y2) Condenser 2 Connector J24 (Y3) Condenser 3</p>	
<p>J22 Pin 1 - 24VAC Output to Condenser 1 J22 Pin 2 - 24VAC Common to Condenser 1 J23 Pin 1 - 24VAC Output to Condenser 2</p>	<p>J23 Pin 2 - 24VAC Common to Condenser 2 J24 Pin 1 - 24VAC Output to Condenser 3 J24 Pin 2 - 24VAC Common to Condenser 3</p>

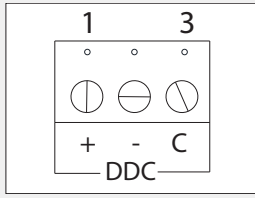
<p>Connector J25 contains low voltage screw terminal connections for DDC Communications Isolated</p>	
<p>Pin 1 - RS-485 + Pin 2 - RS-485 -</p>	<p>Pin 3 - RS-485 Common</p>

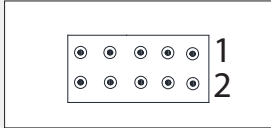
<p>Connector J26 Programming Port</p>	
----------------------------------------------	---------------------------------------------------------------------------------------

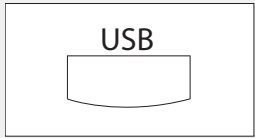
<p>Connector J27 USB Programming Port</p>	
--------------------------------------------------	---------------------------------------------------------------------------------------

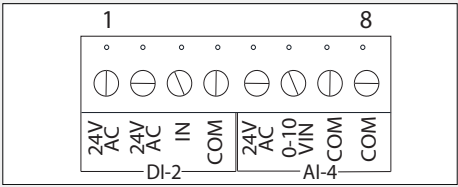
<p>Connector J28 contains low voltage screw terminal connections</p>	
<p>Pin 1 - 24VAC Start Command for 3rd-Party VFD Pin 2 - 24VAC Output Pin 3 - 24VAC Trouble Input Pin 4 - 24VAC Common for 3rd-Party VFD</p>	<p>Pin 5 - 24VAC Constant Output Pin 6 - 0-10VDC Analog Input VFD Speed Reference Pin 7 - 24VAC Common Pin 8 - 24VAC Common</p>

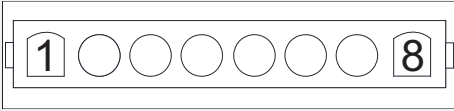
<p>Connector J29 contains 120V AC connections</p>	
<p>Pin 1 - 120VAC Blower Service Switch Input Pin 2 - 120VAC Burner Service Switch Input Pin 3 - 120VAC High Temp Limit Input Pin 4 - 120VAC Output to FSC (6)</p>	<p>Pin 5 - 120VAC Output to FSC (7) Pin 6 - N/A Pin 7 - Purge/Dry Contacts Output Pin 8 - 120VAC Neutral</p>

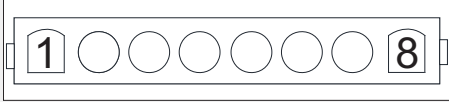
<p>Connector J30 contains 120V AC connections</p>	
<p>Pin 1 - 120VAC Input from Pilot Gas FSC (3) Pin 2 - 120VAC Pilot Gas Output - Connected to J30-1 Pin 3 - 120VAC Input from Spark FSC (4) Pin 4 - 120VAC Spark Output</p>	<p>Pin 5 - 120VAC Input from Main Gas FSC (5) Pin 6 - 120VAC Main Gas Output - Connected to J30-5 Pin 7 - 120VAC Alarm Input from FSC (A) Pin 8 - 120VAC Alarm/Trouble Output</p>

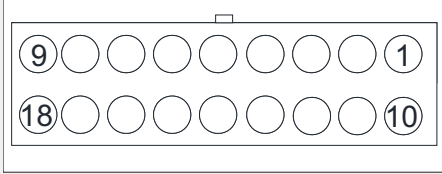
<p>Connector J31 - Contains inputs and outputs for components</p>	
<p>Pin 1 - 24VDC + Output to Profile / Main Air Flow Pressure Sensor Pin 2 - 0-10VDC Analog Input from Profile/Main Air Flow Pressure Sensor Pin 3 - 24VDC/0-10VDC Common from Profile/Main Air Flow Pressure Sensor Pin 4 - N/A Pin 5 - N/A Pin 6 - N/A Pin 7 - 24VDC + Output to Manifold Gas Pressure 1 Sensor Pin 8 - 0-10VDC Analog Input from Manifold Gas Pressure 1 Sensor Pin 9 - 24VDC/0-10VDC Common from Manifold Gas Pressure 1 Sensor</p>	<p>Pin 10 - 24VDC + output to Manifold Gas Pressure 2 Sensor Pin 11 - 0-10VDC Analog Input from Manifold Gas Pressure 2 Sensor Pin 12 - 24VDC/0-10VDC Common from Manifold Gas Pressure 2 Sensor Pin 13 - 24VDC + output to Clogged Filter Pressure Sensor Pin 14 - 0-10VDC Analog Input from Clogged Filter Pressure Sensor Pin 15 - 24VDC/0-10VDC Common from Clogged Filter Pressure Sensor Pin 16 - 24VDC + Output for Analog or Static Pressure Control for Blower/Damper Pin 17 - 0-10VDC Analog Input for Analog or Static Pressure Control for Blower/Damper Pin 18 - 24VDC/0-10VDC Common for Analog or Static Pressure Control for Blower/Damper</p>

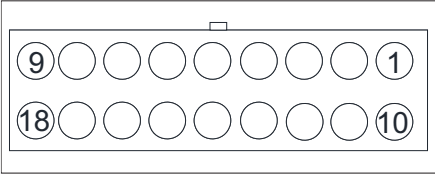
<p>Connector J32 contains inputs and outputs for components</p>	
<p>Pin 1 - N/A Pin 2 - N/A Pin 3 - 24VAC Output for Proof Of Closure Pin 4 - N/A Pin 5 - 24VAC Output To CO Alarm Pin 6 - 0-24VDC + Analog Input from Flame Sensor Pin 7 - 24VDC Powered PWM to Modulating Gas Valve, Full Wave, 16 kHz Pin 8 - 0-10VDC Out for VFD Pin 9 - 0-10VDC Out for EF</p>	<p>Pin 10 - N/A Pin 11 - N/A Pin 12 - 24VAC Input from Proof of Closure Pin 13 - N/A Pin 14 - 24VAC From CO Alarm Pin 15 - 24VDC Common From Flame Sensor Pin 16 - 24VDC Powered PWM to Modulating Gas Valve, Full Wave, 16 kHz Pin 17 - 0-10VDC Common for VFD Pin 18 - 0-10VDC Common for EF</p>

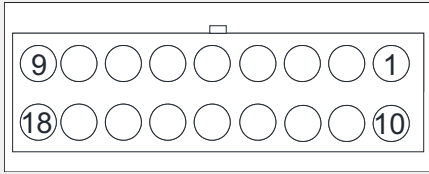
<p>Connector J33 contains inputs and outputs for components</p>	
<p>Pin 1 through 8 - N/A Pin 9 - 0-10VDC Analog Input for CFM</p>	<p>Pin 10 through 17 - N/A Pin 18 - 0-10VDC Common for CFM</p>

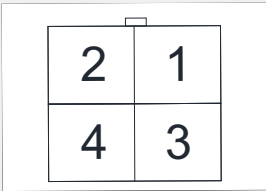
<p>Connector J34 - N/A</p>	
-----------------------------------	--------------------------------------------------------------------------------------

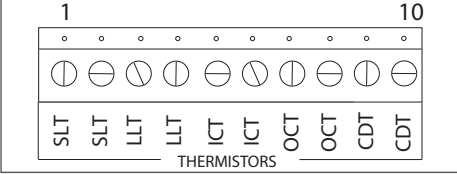
<p>Connector J35 N/A</p>	
---------------------------------	--------------------------------------------------------------------------------------

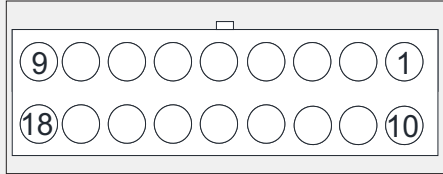
<p>Connector J36 N/A</p>	
---------------------------------	------------------------------------------------------------------------------------

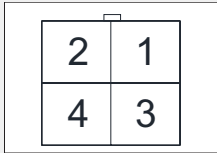
<p>Connector J37 N/A</p>	
---------------------------------	-------------------------------------------------------------------------------------

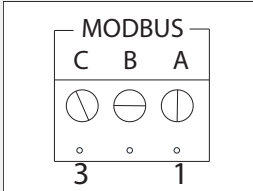
<p>Connector J38 Modbus</p>	
<p>Pin 1 (A) - Modbus (-) Pin 2 (B) - Modbus (+)</p>	<p>Pin 3 (C) - Modbus Ground</p>

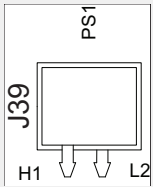
<p>Connector J39 Onboard Airflow Switch</p>	
<p>H1 - High Side</p>	<p>L2 - Low Side</p>

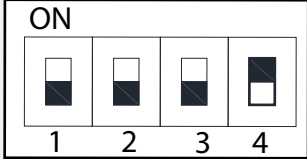
<p>Dip Switch S1</p>	
<p>Switch 1, 2, 3 always OFF. Switch 4 Always ON. If Switch 4 is OFF, BAS terminals disabled.</p>	

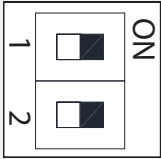
Dip Switch S2	
Programming - Service Only	

Dip Switch S3	
End of line termination	

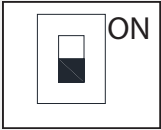
Dip Switch S4	
Programming - Service Only	

Duct Static Pressure Control

Units equipped with an Electrically Commutated Motors (ECMs) or Variable Frequency Drives (VFDs) driven supply fan, the duct static pressure control option can be used to monitor duct pressure.

1. Locate where the pressure transducer is installed in the control cabinet.
2. Install the static pitot tube in a straight section of ductwork where the airflow is laminar and consistent.
3. Connect the high side tubing to the static pitot tube.
4. Route the tubing through the bottom of the unit to the high side port on the pressure transducer.
5. The low side pressure tubing will be connected to a brass port, measuring outdoor ambient pressure. The port is located by the unit's control cabinet doors. This will be connected from the factory.

Figure 13 - Duct Static Pressure Control

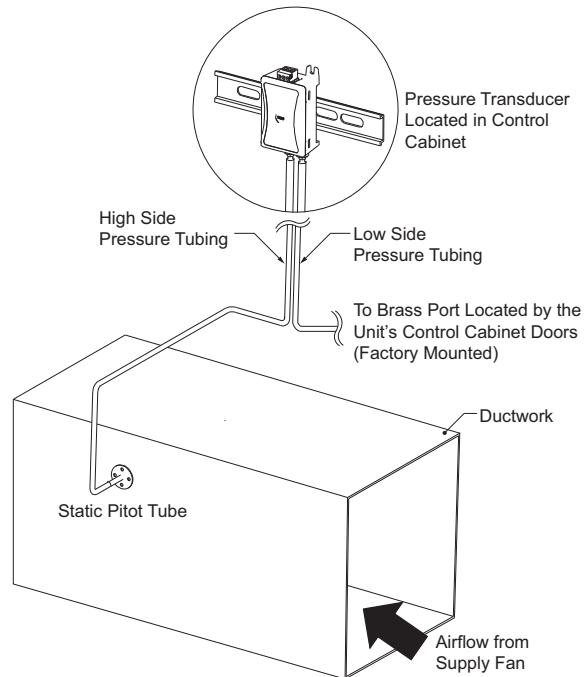

Building Static Pressure Control

Units equipped with an Electrically Commutated Motors (ECMs) or Variable Frequency Drives (VFDs) driven supply fan, the building static pressure control option can be used to monitor space pressure.

1. Locate where the pressure transducer is installed in the control cabinet.
2. Determine the space monitoring device:
 - Room Pressure Pickup Sensor
 - Remote HMI, refer to **"HMI, Space/Wall Sensor, and Room Temp Sensor"** on page 29
3. Install the space monitoring device in the space.
4. Connect the high side tubing to the space monitoring device.
5. Route the tubing through the bottom of the unit to the high side port on the pressure transducer.
6. The low side pressure tubing will be connected to a brass port, measuring outdoor ambient pressure. The port is located by the unit's control cabinet doors. This will be connected from the factory.

Figure 14 - Building Static Pressure Control

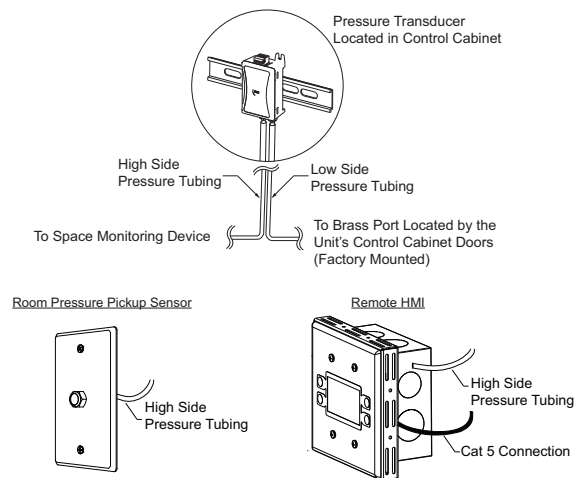

HMI, Space/Wall Sensor, and Room Temp Sensor

NOTE: These components should be installed in a safe location, free of influence from external heat sources. Sensors must be installed in areas indicative of the average room temperature. Mounting the sensor(s) to interior walls will provide reliable measurements.

HMI (Human Machine Interface)

The HMI is used to change settings, view operating information, and view fault history. Remote HMI faceplates (**Figure 15**), remote room sensors (**Figure 17 on page 30**), and smart controls may be ordered and shipped separately. These components measure temperature and humidity and assist in controlling the unit. Mounting the sensor(s) to interior walls will provide reliable measurements. Keep the sensor away from heat-producing appliances, direct sunlight, and away from operable windows/doors.

HMIs and remote room sensors can be installed directly to industry-standard junction boxes, either surface mounted or recessed mounted. HMIs have a built-in temperature/relative humidity (RH) sensor, which is typically used to help control the automatic function of the unit.

The HMI can also be configured to control the unit from a remote location manually. They can be configured not to use the internal temperature/relative humidity sensor. In this configuration, the sensor in the HMI is ignored in automatic operation. Multiple HMIs can be connected to one unit for temperature and R/H averaging. All combination temperature/humidity HMIs will use a vented standoff. Mount the static pressure tube close to the HMI to obtain proper room conditions.

A max of 4 additional HMIs can be daisy-chained together. Place an End-of-Line (EOL) device in the last HMI connected.

Figure 15 - HMI with Standoff

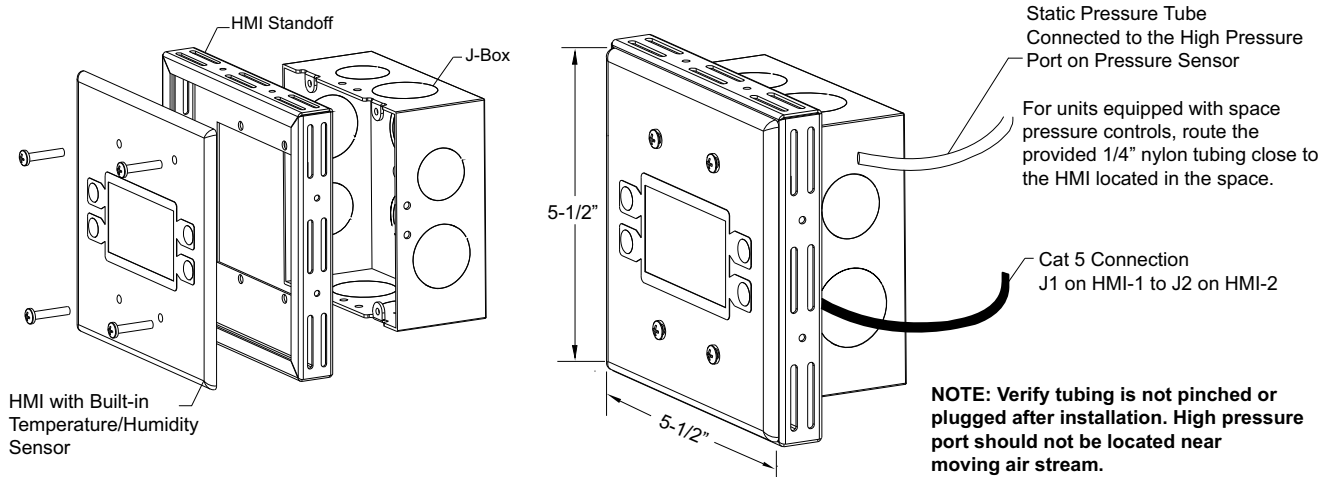

NOTE: These components should be installed in a safe location, free of influence from external heat sources. Sensors must be installed in areas indicative of the average room temperature. Mounting the sensor(s) to interior walls will provide reliable measurements.

Space HMI Control Panel

The space HMI(s) will be located in an area where the user may make comfort adjustments to the space. On units shipped with a space HMI, a Cat 5 cable will need to be run from J4, J5, or J6 (refer to schematics) on the main MUA Board to J2 on the HMI. If additional space HMIs have been added, they can be daisy-chained from the first HMI. In the event there is a slave MUA Board, HMIs can also be powered from J1 or J2 of the slave board. An end of line resistor should be added to the last HMI in the chain. Refer to **“Space HMI Menu” on page 35** for space HMI menu navigation.

NOTE: Some space HMIs may be CAS Wall Sensors, which function and look like HMIs but without a screen or buttons. To assign MODBUS Address, refer to Figure 16. The switches are on the back of the sensor.

Figure 16 - CAS Wall Sensor DIP Switches

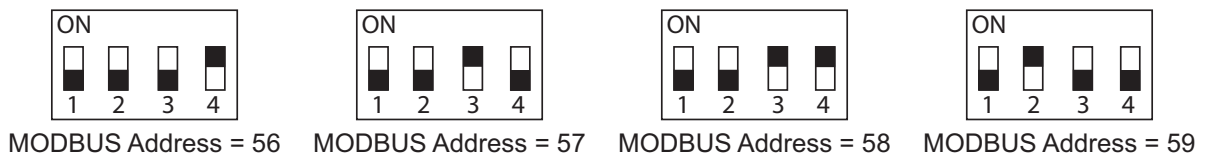

Room Temp Sensor

The room temperature/humidity sensor is a 10K ohm thermistor. When connected to the 0-10V humidity sensor connection, the sensor provides constant room temperature and humidity (RH) readings to the controller. The sensor should be installed on a wall somewhere in the room, but not directly in the HVAC diffuser’s path or close to heat-producing appliances so that the reading is not affected by heat.

Room sensors are not required for proper control operation, but still can be configured as remote sensors or averaging sensors.

Do not install the room sensor on the ceiling.

Figure 17 - Remote Temp/RH Sensor

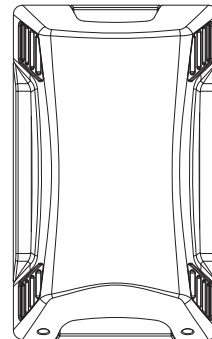

Temperature Control

Discharge Control: When used in discharge control, the MUA Board receives a call to heat from the intake sensor. The MUA Board will modulate the discharge temperature until the desired set point is reached. The user can choose whether discharge heating/cooling is activated based on intake temperature, space temperature, either, or both.

Space Control: When selected, an HMI with an internal temperature sensor or a temperature sensor wired to ST terminals on the MUA Board can be used to sense space temperature. The user can choose whether the space heating/cooling is activated based on intake temperature, space temperature, either, or both.

Analog Control: If Analog Control is utilized, DIP switch #4 on the MUA Board should be set On. Blower/Heating/Cooling will be controlled by a 0-10V DC or 0-20mA signal based on input source.

Scan for DDC Application Guide

Direct Digital Control (DDC): A 0-10V DC or 0-20mA signal is sent to the MUA Board from the building control system to regulate the blower/heating output of the unit. For DDC information, refer to [DDC Application Guide](#).



In all cases, the MUA Board controls the amount of gas to the burner based on the signal from the temperature control components.

Maxitrol Modulating Valve

The operation of the modulating gas valve with regard to voltage is as follows: from 0 volts to approximately 5 volts, the modulating gas valve should be on bypass flow with the heater operating on low or minimum fire. From approximately 5 volts to 15 volts DC, the valve should be performing its modulating function, and the heater should be firing at a modulated flow rate between low and high fire, depending upon the voltage. Above approximately 15 volts DC, the valve should be delivering full flow to the heater and the unit should be on high fire.

RTC Modulating Valve

The operation of the modulating gas valve with regard to voltage is as follows: From 2 volts to 10 volts DC, the valve should be performing its modulating function, and the heater should be firing at a modulated flow rate between low fire and high fire, depending upon the voltage. The low fire and high fire voltage limits are set in the factory settings.

Thermistor

The temperature sensor (**Figure 18**) is a 10K ohm thermistor. The sensor gives constant feedback to the control board.

Figure 18 - Temperature Sensor

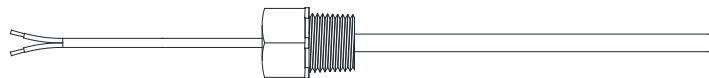

Thermistor Connected to HMI

Thermistors connected to connector J5 on the HMI may be averaged or used as a standalone for space temperature readings.

OPERATION

Accessing Menu Configurations

General Overview

The HMI (Human Machine Interface) allows the user to change parameters and options. The user may use the unit HMI only to view operating information regarding sensors, temperatures, and pressures on the HMI screen (**Figure 19**).

There are four buttons to navigate through the HMI screens.

NOTE: Buttons change functions during certain options and tests. Verify the screen and buttons throughout the menu display.

When the HMI Home Screen is active, the Temp +/- buttons may be used to adjust basic temperature settings. Adjustments made are not permanent, and are based on Occupancy Configuration and Override Duration parameters in Factory Settings which are only accessible from the unit HMI.

The user can access the Top Menu HMI configurations by pressing the top two buttons simultaneously. To exit this screen, simply press the 'BACK' button. When setting certain options or functions, pressing the 'BACK' button multiple times will bring up the save screen (**Figure 20**). The user may select 'YES' to save the changes, select 'NO' to return to factory settings, or select 'CANCEL.' When selecting 'CANCEL,' any changes made will not be saved, and the screen will return to the top menu.

Unit HMI Control Panel

The unit HMI menu system allows full access to every configurable parameter in the HMI. The parameters are factory configured to the specific application. Parameters may need to be modified to fine-tune automatic operation after the original setup. Parameters are locked out by a password and may only be accessed through contacting a service representative.

For information on the Space HMI, refer to **“Space HMI Control Panel” on page 30**. For menu navigation, refer to **“Space HMI Menu” on page 35**.

HMI Notification Letters

The HMI will display notification letters (**Figure 21**) when the unit is in a specific status.

- B = Blower Start or Blower Stop Delay Active.
- C = Condenser Min On or Min Off Timer Active. Displayed when any of the condensers are in a Min On/Off Time.
- F = Fault (Space HMI Only).
- D = Min or Max Discharge Temp Reached.
- M = Max Temp Rise Reached.
- R = OA Reset.
- Δ = Dynamic SP Applied.

Figure 19 - HMI Screen

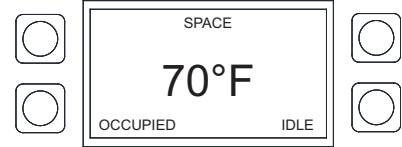

Figure 20 - Save Screen

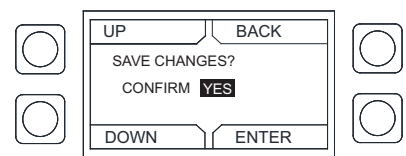
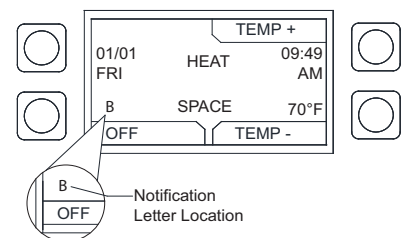

Figure 21 - Notification Letters



HMI Configuration Menu

To enter the configuration menu (**Figure 22**), press the bottom two buttons simultaneously on the HMI faceplate. In this menu screen, you may adjust Communication and Advanced Options, check Status, and About information.

Figure 22 - Configuration Menu

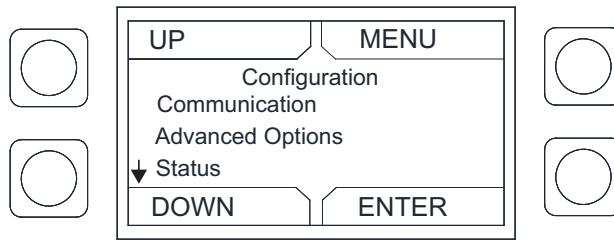

Communication

Under the communication menu, the user may adjust the following settings:

- **Modbus Address** - Default is 55 for the first HMI. For every additional HMI, increase the address by one. For example, if a second HMI is used, the Modbus Address should be 56. For a third HMI, the Modbus Address should be 57.
- **Baud** - Do not adjust this setting. The baud rate address is 115200.
- **Parity** - Do not adjust this setting. The default setting should always be set to 'EVEN.'

Advanced Options

Under advanced options, the user may adjust the following settings:

- **Contrast** - The user may adjust the setting from 0 to 10. Setting the contrast to 0 is the lowest setting available, and 10 is the highest contrast setting available. The factory default contrast setting is 5.
- **Audio Enable** - User may set the audio to off.
- **Dimming Enable** - Default is set to Off. If set to On, the 'HMI Dimming Timer' option will be available.
- **Set Time** - The user may adjust dimming setting from 10-60 seconds. The default time is 30 seconds.
- **RH Chip** - Relative Humidity sensor manufacturer. This setting is auto-detected. **DO NOT CHANGE SETTING.**
- **Temp Offset** - Applies a temperature offset to the space HMI reading utilized by MUA Board. Must be set local to each space HMI. Range +/- 20°F. Calibrated individually from the manufacturer. User must consult with manufacturer before making adjustments.
- **RH Offset** - Applies a relative humidity offset to the space HMI reading utilized by MUA Board. Must be set local to each space HMI. Range +/- 30%. Calibrated individually from the manufacturer. User must consult with manufacturer before making adjustments.
- **PS Offset** - Applies a pressure offset to the space HMI reading utilized by MUA Board. Must be set local to each space HMI. Range +/- 200 mb. Calibrated individually from the manufacturer. User must consult with manufacturer before making adjustments.

Status

User may monitor board temperature status, Uptime (how long the board has been active since last restart), HW RH (HMI hardware humidity sensor), HW Temp (HMI hardware temperature sensor).

About

User may view SCADA HMI Software Version, Modbus Address (assigned to HMI), Baud (115200).

Scheduling on Unit HMI

To set a schedule on the HMI (**Figure 23**), you must first enable scheduling on the unit HMI: **Factory Settings > Occupancy Config > Scheduling > On**

Set your sensor temperature set points for occupied and unoccupied schedules: **User Settings > Temp Set Points > (Varies)**

Once scheduling is enabled and the temperature set points are configured, you may enter your scheduled days and times: **User Settings > Scheduling**

Schedule A Default

- Monday - Friday
8:00AM to 6:00PM
- Saturday and Sunday
Unocc

Schedule B Default

- Monday - Friday
Unocc
- Saturday and Sunday
Unocc

Schedule C Default

- Monday - Friday
Unocc
- Saturday and Sunday
Unocc

Figure 23 - Scheduling Screen

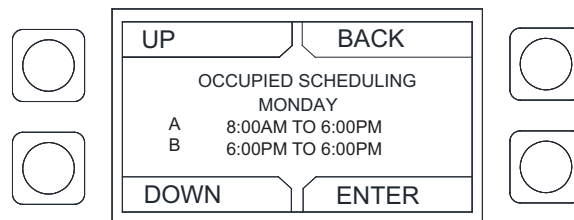

To adjust the settings, highlight the parameter and press **ENTER**.

- The first parameter to be highlighted will be the day. Press **UP** or **DOWN** to select the day an occupied time schedule is required.
- Press **ENTER** to continue to set a start time. Press **UP** or **DOWN** to set start time.
- Press **ENTER** to set an end time. Press **UP** or **DOWN** to set end time.

The system will run between these days, time, and desired temperature settings. When in the UNOCCUPIED setting, the system will run at the unoccupied temperature settings.

Scheduling on Space HMI

When scheduling is enabled in Factory Settings, the space HMI will have scheduling available.

Set your Space/Discharge temperature set points for occupied and unoccupied schedules: **Space/Discharge Set Points > (Varies)**

Once scheduling is enabled and the temperature set points are configured, you may enter your scheduled days and times: **Scheduling**

Schedule A Default

- Monday - Friday
8:00AM to 6:00PM
- Saturday and Sunday
Unocc

Schedule B Default

- Monday - Friday
Unocc
- Saturday and Sunday
Unocc

Schedule C Default

- Monday - Friday
Unocc
- Saturday and Sunday
Unocc

Space HMI Menu

The user can access the Space Top Menu HMI configurations by pressing the top two buttons simultaneously.

- **Discharge Set Points** - User adjustable SP for heating and cooling discharge tempering targets.
 - **Heat** - The unit will target this discharge temperature in heating mode. Tempering mode must be set to discharge or stat. Heating Type configuration must be set.
 - **Cool** - The unit will target this discharge temperature in cooling mode. Tempering mode must be set to discharge or stat. Cooling Type configuration must be set.
- **Space Set Points** - User adjustable SP for heat and cool space activation and tempering.
 - **Heat** - Heating will activate if the space temperature is below this value. The unit will target this space temperature after heating is active. "Activate Based On" must be set to Space, Both, or Either. Heating Type must be set to a heating configuration.
 - **Cool** - Cooling will activate if the space temperature is above this value. The unit will target this space temperature after cooling is active. "Activate Based On" must be set to Space, Both, or Either. Cooling Type must be set to a cooling configuration.
- **Scheduling** - Only active when the scheduling is set to On.
 - **Schedule Times** - Each day contains the option for three occupied time periods. If the time is set past 11:59 pm, it will display 'UNOCC'.
 - **Copy Schedule** - This will allow the user to copy an existing schedule from one day of the week to individual days in the week, to Week Days, or All.
- **Active Faults** - Contains the current faults on the board.
- **Fault History** - Displays time-stamped history of the last 20 faults, most recent fault showing first.
- **Reset Lockouts** - Displayed when a lockout fault has occurred. Enter menu to reset fault(s).
- **Job Info** - Non-editable parameters. Displays Job #, Unit #, HMI #, Tag (HMI Name e.g, Office/Hallway/Break Room) entered at the factory.

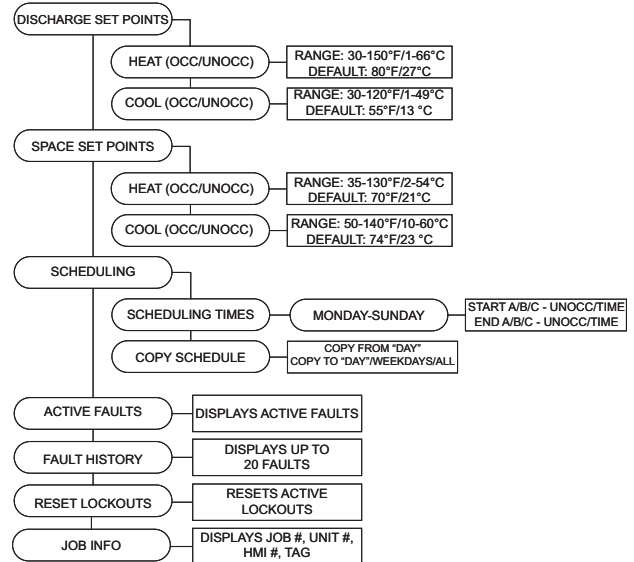

Menu Descriptions

User settings: Allows the user to change or set certain temperatures and configurations on the unit.

Factory settings: Requires a password for access. Factory settings are job-specific and configured from the plant. Any changes to the factory settings will require the user to save the updated changes. Refer to **“Technical Support Information” on page 80.**

Service settings: Requires a password for access. Provides access for a certified technician to monitor the unit and test components in the system. Refer to **“Technical Support Information” on page 80.**

About: Unit type and software revision information.

User Settings

Temp Set Points - Some or all of these set points (SP) may not be available based on settings. If scheduling is enabled, there will be occupied and unoccupied values for set points. The user will be allowed to view/ adjust the set points/limits.

- **Intake Set Points** - Adjustable intake activation SP.
 - **Heat** - Activate Based On must be set to Intake, Both, Either, or Stat. Heating stage must = 1.
 - **Cool** - Activate Based On must be set to Intake, Both, Either, or Stat. Cooling type set to DX or Both.
 - **Evap** - Activate Based On must be set to Intake, Both, Either, or Stat. Cooling type set to Evap or both.
- **Discharge Set Points** - Adjustable heat discharge activation SP.
 - **Heat** - Tempering mode must be set to discharge. Heating stage must = 1.
- **Space Set Points** - Adjustable heat/cool space activation SP.
 - **Heat** - Activate Based On must be set to Space, Both, or Either. Heating stage must = 1.
 - **Cool** - Activate Based On must be set to Space, Both, Either, or Stat. Cooling type set to DX, Evap or Both.
- **Discharge Limits** - Adjustable discharge limit SP.
 - **Min** - Cannot be greater than maximum discharge heat SP.
 - **Max** - Cannot be less than minimum discharge heat SP.
- **Differentials** - Adjustable intake/cool space SP.
 - **Intake** - Activate Based On must be set to Intake. Cool tempering mode set to Intake.
 - **Space** - Activate Based On must be set to Space. Cool tempering mode set to Space.
- **Option Set Points** - Adjustable set points for options that are enabled to **“ON”** in Factory Settings.
 - Room Override, Firestat Set Points, Freezestat Set Points, Cab Heat Set Point, Evap Drain Set Point, Warm Liq Set Points, OA Reset Low, OA Reset High, Reset Heat Discharge, Reset Heat Space, Reset Cool Space, Disable Space Sensor.

Dry Mode Config - The user will be allowed to view or adjust dry mode set points/limits when the option is enabled.

Scheduling - Menu will display when scheduling is set to On.

- **Scheduling Times** - Days contain the option for three occupied time periods. Time periods cannot overlap.
- **Schedule Copy** - This will allow the user to copy an existing schedule from one day of the week to individual days in the week, to Week Days, or All.

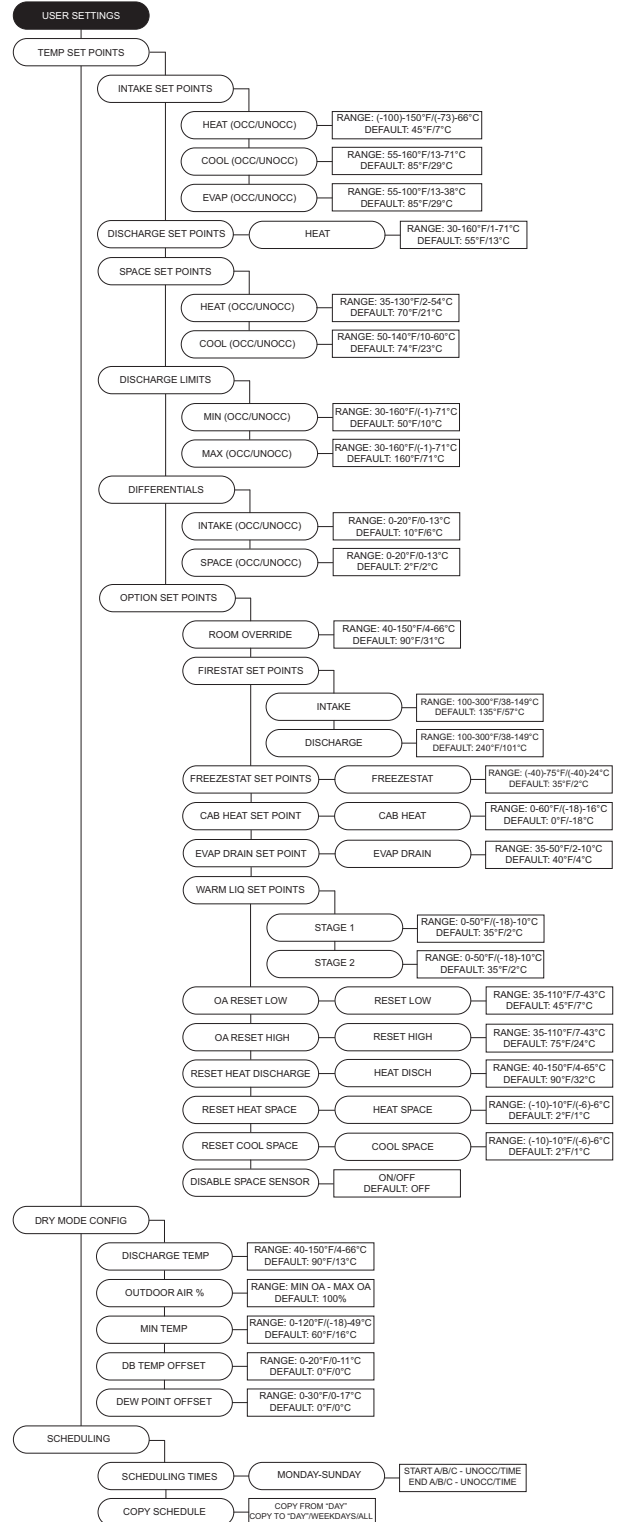

Fan Speed - Enabled when the supply fan is controlled by a VFD or ECM. The range of this menu is limited by the min and max set points (SP) under factory settings. When the fan is set to VFD, the settings will be displayed in: Hertz (VFD by Other = OFF); Volts (VFD by Others = ON). When the fan is set to ECM, the PWM percentage will be displayed.

Clogged Filter SP - Displayed when “Filter Mon” is set to sensor in **Factory Settings > Unit Options > Monitoring Sensors**. This adjustable SP will display a fault on the HMI when the reading is below SP for five minutes.

Mixing Box Setting - Mixing box will allow outdoor air in vs. return air. 0V out is equal to 100% OA and 0% RA.

Pressure Config - Settings vary based on **Factory Settings > Unit Options > Pressure Config**.

- **Blower PS SP** - Adjustable blower pressure set points.
- **OA PS SP** - Adjustable outdoor air pressure set points.

Single Zone VAV - When single zone VAV is enabled to the blower, damper, or both, depending on settings, will modulate linearly between min and max discharge.

- **Blower Speed Heat** - Blower to modulate with discharge temp min discharge, min blower speed. Max discharge, max blower speed. Scaled linearly between min/ max discharge to min/max blower speed.
- **Damper Pos Heat** - Damper to modulate with the discharge temp min discharge, min damper position. Max discharge, max damper position. Scaled linearly between min/max discharge to min/max damper position.
- **Blower Speed Cool** - Blower speed will change depending on how many cooling stages are active. Evap counts as 1st stage of cooling.
- **Damper Pos Cool** - Damper position will change depending on how many cooling stages are active. Evap counts as 1st stage of cooling.

Active Faults - Contains the current faults on the board.

Fault History - Displays time-stamped history of the last 20 faults. The most recent fault will show first.

Reset Lockouts - Reset lockout faults.

Dynamic SP Diff - Temperature differential for dynamic set point change.

Dynamic SP Offset - Setting will adjust dynamically based on outdoor air conditions. For more information, refer to “Dynamic Set Point” on **page 48**.

Dynamic Heat OA - Outdoor air dynamic heat set point.

Dynamic Cool OA - Outdoor air dynamic cool set point.

CO2 Control Config - CO2 Parts Per Million (PPM) set points and sensor settings.

- **PPM Low/High** - CO2 PPM threshold set points for the space, used in CO2 Override.
- **PPM Limit** - CO2 PPM threshold limit set point.
- **Sensor Min/Max** - Set minimum and maximum range setting for CO2 sensor.

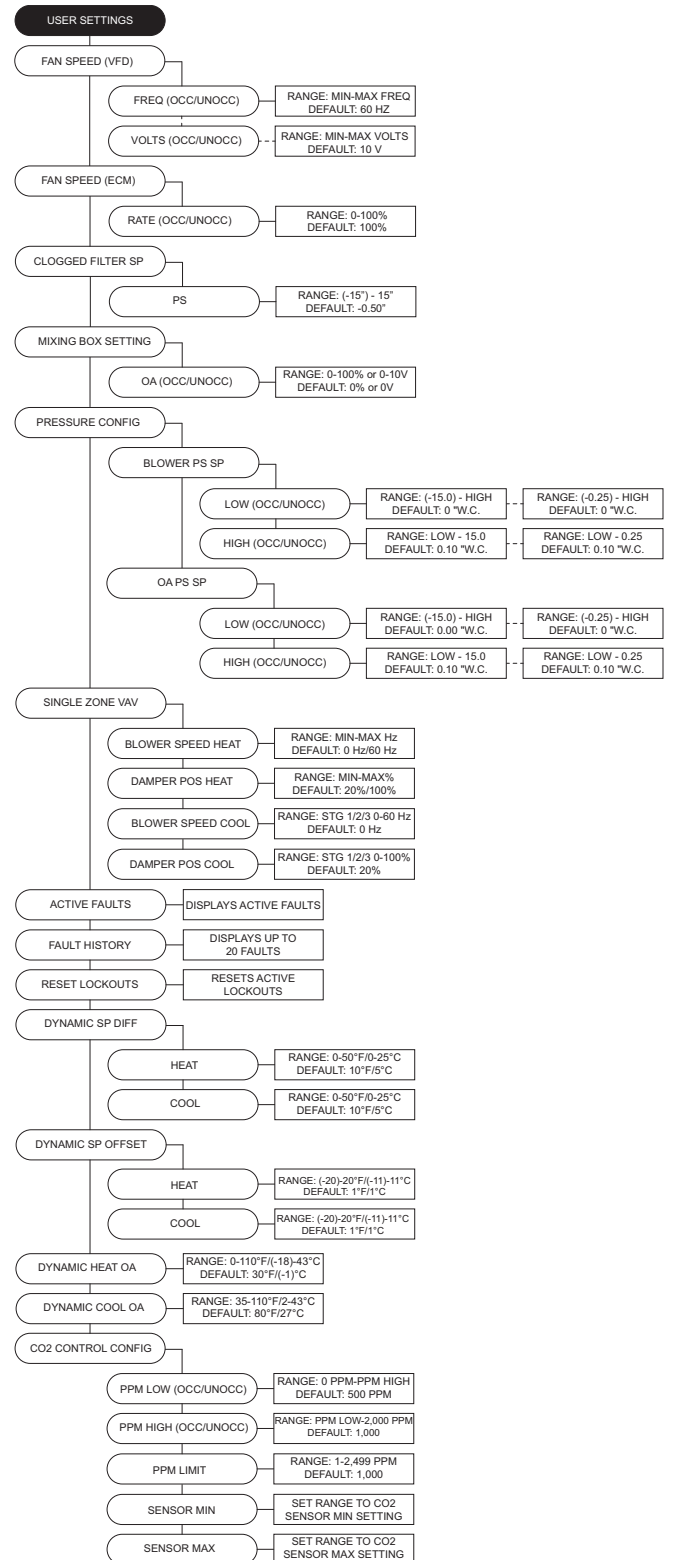

Factory Settings

Heating Type - Unit heating type set from the factory.

Temperature Control - The MUA Board monitors temperature control set points and components.

- **Tempering Mode** - The options for controlling the output of the tempering mode in heat/cool (if equipped). Available options are Intake/Discharge/Space/Analog Control/Direct Digital Control (DDC).
- **Activate Based On** - Unit activation based on temperature readings: Intake/Space/Both/Neither/Stat (field installed thermostat). Settings can be altered for occupied and unoccupied preferences.
 - When Activate Based On is set to Stat, thermostat inputs and intake temperatures are monitored to activate heating/cooling.
- **Activation Sensor** - Selection for unit activation of intake or outdoor sensor.
- **Construction Mode** - Configurable option for units used in construction settings. When construction mode is enabled On, the following factory settings will be overridden: HMI, Discharge Control, 100% Outside Air, Activate Based on Intake, Blower Mode set to Manual.

Heating Config - Heating configurations/settings.

- **# of Heat Stages** - Default is set to 0 for units without gas heat. If the unit is equipped with gas heat, select 1.
- **Gas Type** - Select gas type: natural gas or propane.
- **Gas Valve Limits** - This setting adjusts the unit's gas valve range. You may adjust the Min or Max percentage range.
- **Low Fire Config** - Allows the user to set low fire time and valve position settings.
 - **Time** - The amount of time the low fire setting is applied before modulation will occur.
 - **Valve Pos** - Gas valve position before modulation occurs.
- **Heat Hyst** - Intake or Space tempering sensor must go this amount of degrees above the set point before heating turns off.
- **Input Source** - This lets the board know what signal (volts or milliamps) to expect from the analog control system. **Only valid for analog tempering mode.**
- **2nd Disch Sensor** - When an additional thermistor is added, the two thermistor readings will be averaged together.
- **Average High Temp** - When the "2nd Disch Sensor" is On, this menu will be available. When "Average High Temp" is Off, if either discharge sensor goes above high temp limit the unit will go into high temp lockout. When "Average High Temp" is On, both thermistors readings will be used to determine high temp lockout.

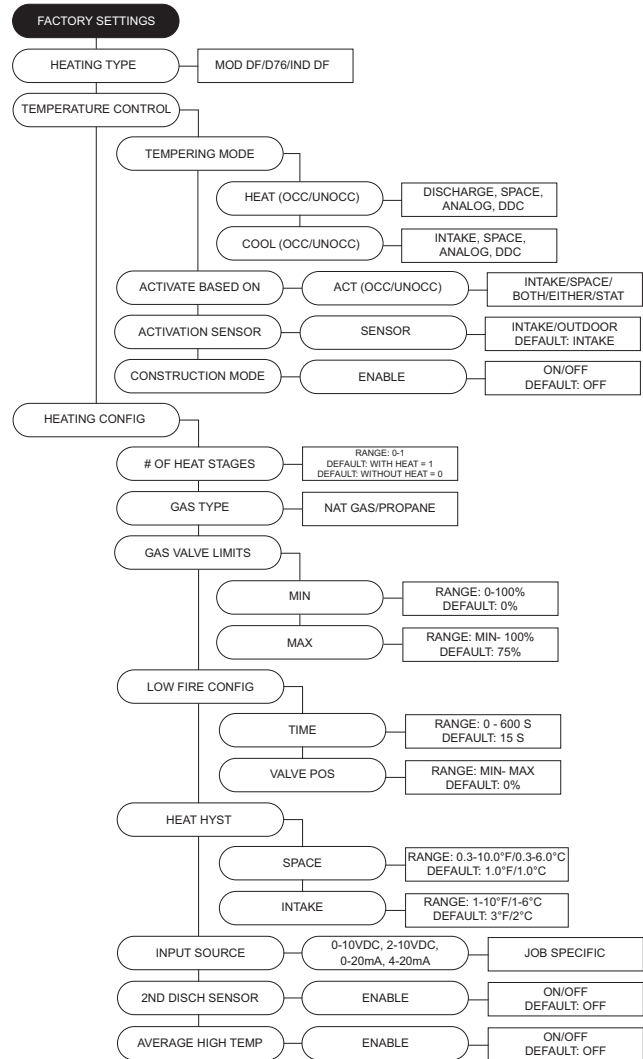

- **Pre Purge Config** - When enabled, the option will purge any gas that may not have combusted in the unit before the unit lighting off. You may set the amount of time the purge cycle will operate.
- **Cabinet Hyst** - The cabinet temp must reach this many degrees above the activation set point to turn off.
- **Freezestat Timer** - If the discharge temperature is below the freezestat set point for half the duration of the freezestat timer, the heat will shut off momentarily. If the freezestat trips for a second time, the heat will shut down immediately. Reset the lockout manually on the HMI.
- **Construction Heater** - When this option is set to On, settings will override any other airflow proving values and high-temperature setting.
- **Max Temp Rise Limit** - Compares max rise limit to calculated max temp rise. Software will always utilize the lower of the two values.
- **Blwr Off Flame Fail** - When enabled On, the blower will shut down if a flame lockout occurs. The blower may go back into operation after the fault is cleared.
- **HTL Blower Off** - The blower will shut off when the high temperature limit trips.
- **Min/Max Heating** - When enabled On, low fire percentage is configurable under **Service > Test Menu > Test Heating > Low Fire**.

Cooling Config - Cooling configurations/settings.

- **Cooling Type** - Options are hidden if "None" is selected.
- **Extra Cooling Input** - When DX cooling stage is set to 2 or greater, the cooling input will utilize all cooling stages.
- **Min Cool OA Temp** - When the space temperature calls for cooling, and the outdoor air temperature is below the set point (SP), the unit will shut the condensers off. The blower will start and use outdoor air to cool the space.
- **Condenser Staging** - Condenser selections. Within the 2 and 3 condenser selection, there is another sub-menu that allows for 2 or 3 stages. For 2 condenser units, 3 stages should only be selected when the condensers are of unequal tonnages.
- **Cool Hyst** - Intake or Space tempering sensor must fall this many degrees below the SP before cooling turns off.
- **Condenser Min Times** - Minimum time each condensing stage must remain on after activation. This prevents stage cycling. **A "C" will be present in the lower-left corner of the home screen when any of the condensers are in a MIN ON/OFF TIME.**
- **DX Float Switch** - Enables DX float switch option.
- **Evap Config**
 - **Sprayer Times**
 - **Time On** - Evaporative cooler spray time on cycle.
 - **Time Off** - Evaporative cooler spray time off cycle.
 - **Evap Drain** - Units that use evap drain, set to On.
 - **Drain Hyst** - Temperature differential setting before the drain shuts off.
 - **Evap Hyst** - Temperature differential before the evap cooling shuts off.

Occupancy Config - Access to Scheduling/Override.

- **Scheduling** - Sets scheduling On/Off.
- **Override** - Sets occupancy override On/Off.

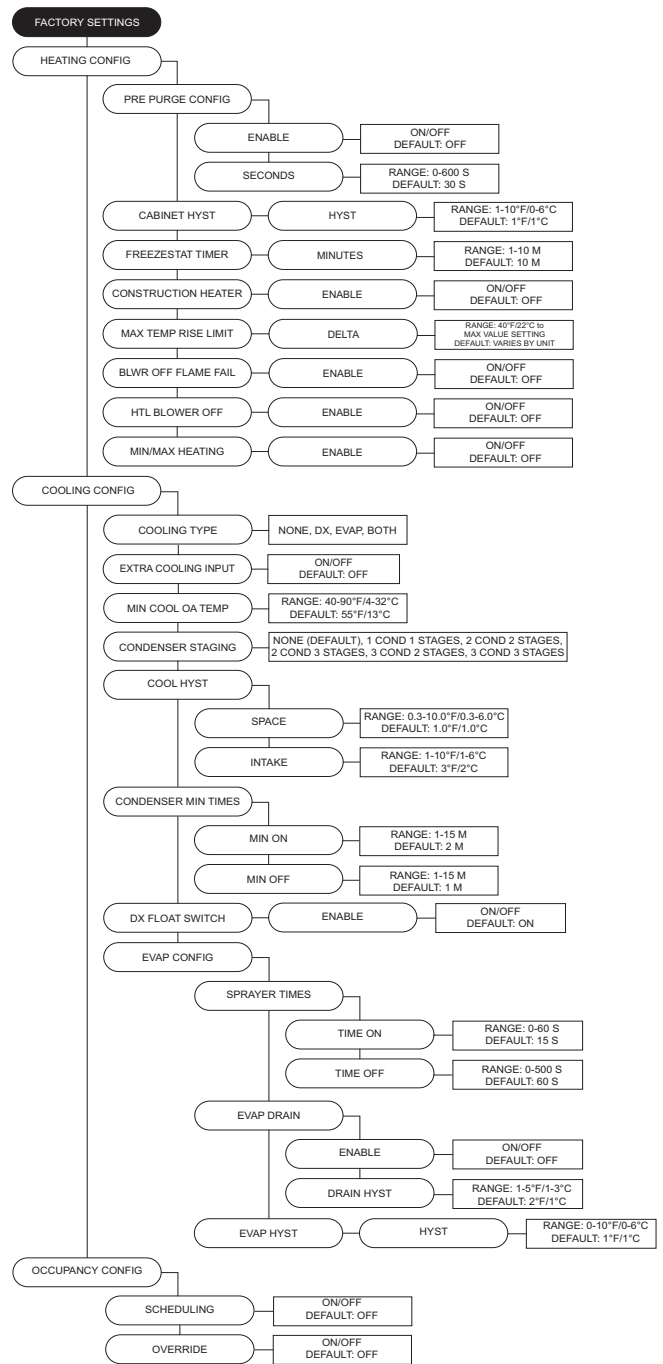

Unit Options - Access to options included with the unit.

• **Board Config**

- **Unit Address** - Modbus address of the MUA Board.
- **Startup Timer** - Time upon power-up where the board will sit idle.
- **Temp Readings** - Allows user to set temperature readings between Fahrenheit or Celsius. Changing between the two will reset all set points.

• **HMI Config** - Adjustment for HMI settings/options.

- **Number** - HMI count connected to the MUA Board.
- **Dis Space** - Select display space temperature option. Faceplate will display the room's current temperature. Average will display an average of all faceplates, excluding HMI in the unit, and all wired space sensor readings.
- **Screensaver** - When Off, the home screen will not time out to the screensaver.
- **Average HMI** - When multiple space HMIs are connected, this menu allows you to select which will be included in the space temperature and relative humidity averaging. If a thermistor or relative humidity sensor is connected into the ST screw terminals, it will automatically be averaged into any HMIs included. When in Space Tempering Mode, a minimum of one HMI must have Average HMI set to On, or a separate remote sensor must be used that is wired back to the MUA Board. When average HMI is set to more than 1, each HMI will have an averaging On/Off setting.
- **Temp Stat #** - On/Off option to turn on temperature averaging for wired HMI thermistors.
- **Lock Screen** - When On, a password (9999) will be required if; screensaver option is enabled or if any button functions are not pressed for 5 minutes.
- **Scnsvr Disp** - Displays date, time, and/or temperature/RH, when screensaver is active.

• **DDC Main Config** - **Network settings should not be changed if the unit is equipped with BACNET.**

- **Baud** - The baud rate for Modbus.
- **Word Bits** - Data bit amount over Modbus.
- **Parity** - The parity selection for Modbus.
- **Stop Bits** - The stop bits selection for Modbus.

• **PGA HW Type** - (DO NOT CHANGE SETTINGS)

• **BMS Write Enable**

- **User Settings** - Allows BMS to write to user settings.
- **Factory Settings** - Allows BMS to write to factory settings.

• **Timer Config** - (DO NOT CHANGE SETTINGS)

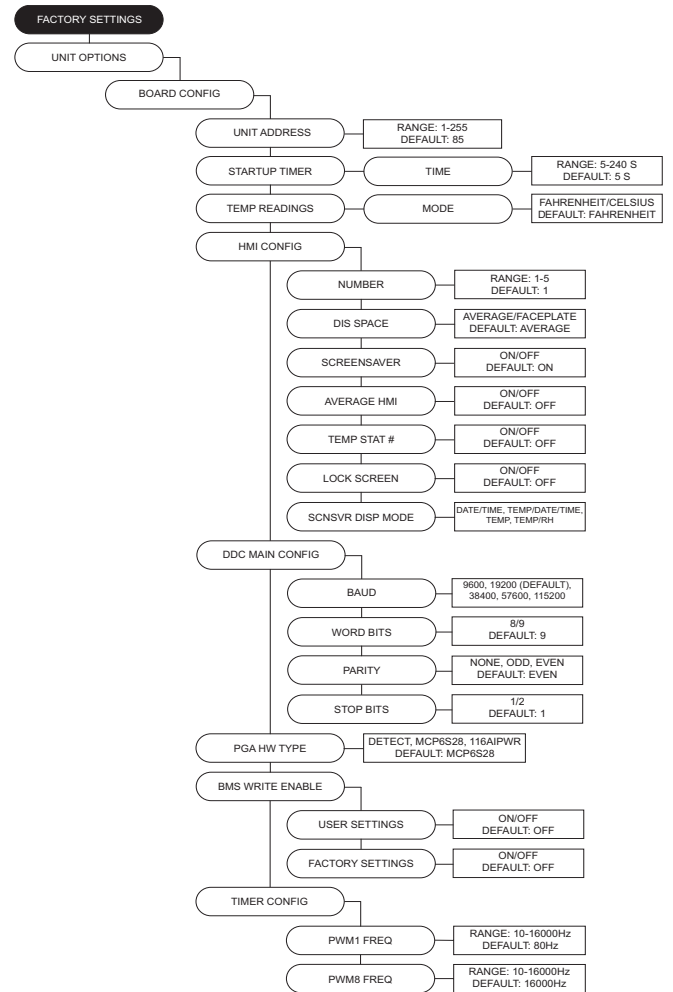

- **Blower Config** (refer to **Table 6** for aux pin settings).
- **Blower Control** - Select one of the following:
 - **120V Contactor** - 120V output on the MUA Board to energize the supply contactor coil. This option should be selected when the MUA is used in conjunction with a DCV package.
 - **VFD Manual** - HMI selectable VFD frequency.
 - **VFD Jog** - For use with VFDs using photohelic control. Aux pins are used to control the VFD. Powering aux 1 will speed the fan up, powering aux 2 will slow the fan down. When aux 1 or aux 2 are not powered, the VFD will hold current speed.
 - **VFD 0-10V** - For use when an external 0-10V signal is being provided to control the speed of the VFD. 0 Volts will equal VFD min, 10V will equal VFD max, and all voltages in between will be scaled linearly. This option will utilize 0-10V J28-(6) and 0-10V common J28-(7) screw terminals, and will require field wiring.
 - **VFD Pressure** - For use with VFDs that use a pressure transducer (0-10V output).
 - **Electronically Commutated Motor (ECM)** - HMI selectable PWM rate.
 - **ECM 0-10V** - For use when an external 0-10V signal is being provided to modulate the ECM supply output between min and max speed.
 - **ECM Pressure** - For use with ECMs that use a pressure transducer (0-10V output).
 - **ECP** - For use when the unit is controlled by an Electrical Control Package (ECP). MUA Board will still energize 120V supply contactor when there is a call for blower. Power to FSC cuts out at shutdown for 30 seconds.
- **Blower Mode:**
 - If "Occ" is set to On, the menu screen for the blower mode will allow you to choose ON/AUTO OFF for Occupied or Unoccupied.
 - If "Occ" is set to Off, the menu screen for the blower mode will allow you to choose MANUAL/AUTO/INTER-LOCK. In blower auto mode, the blower will only run when it gets a call for heating/cooling.
 - In blower manual/on mode, the blower will run as long as the fan button is enabled regardless of whether the unit is heating/cooling. In blower off mode, closing contacts J16-5 (unit intlk) and J16-6 (24V AC) will cause the blower to run.
- **Air Profile Limits** - Low PS cannot be adjusted below min setting, and High PS cannot be adjusted above max settings. Adjusting limits between min/max values may affect unit operation.
- **Blower Presets** - Sets blower preset option On/Off.
- **Post Purge Config** - This option will run the blower for the set time after heating has shut down.
- **Door Interlock** - When enabled, if the door is open, the supply fan will shut down immediately.

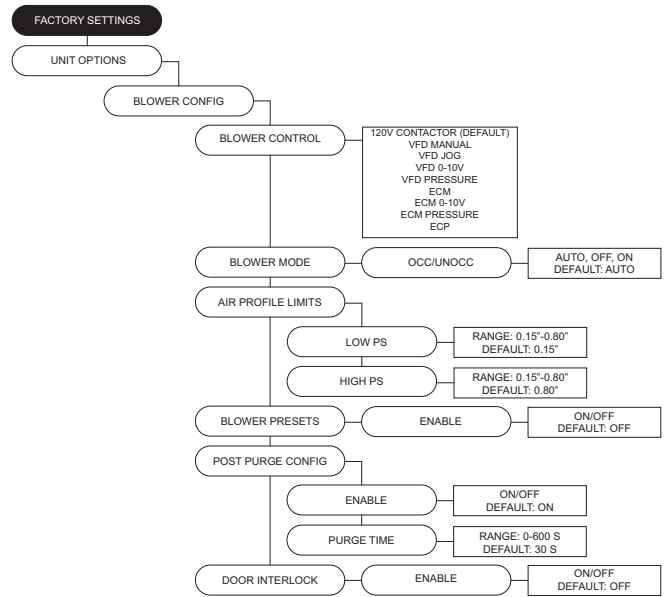
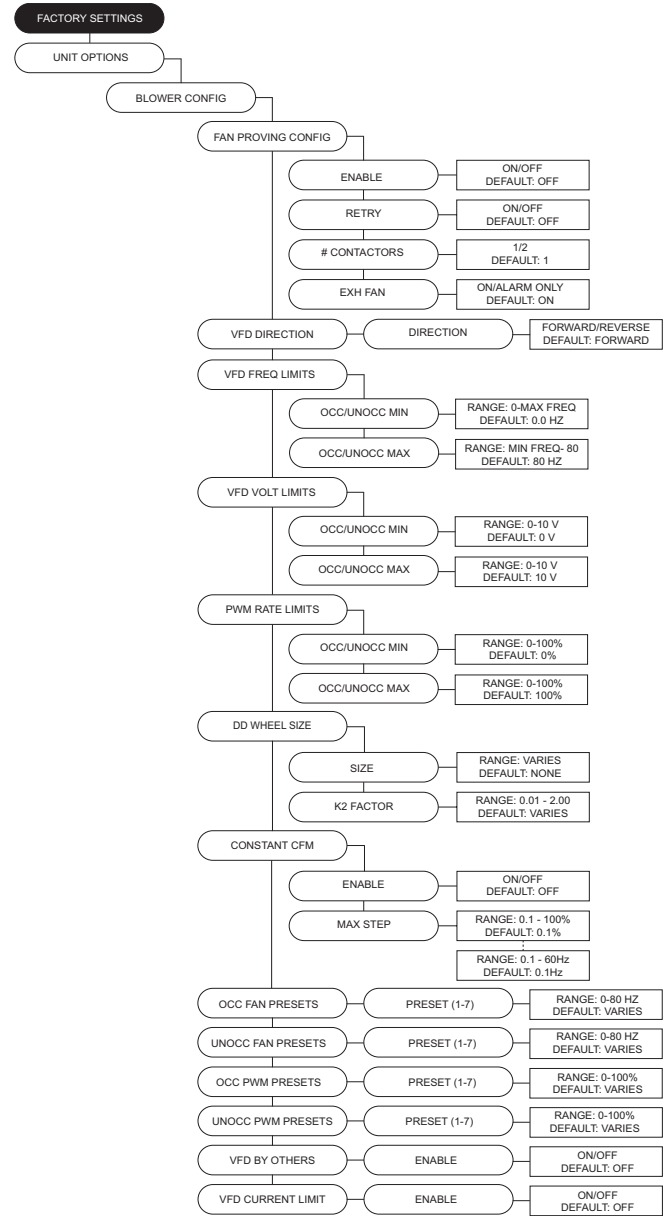

Table 6 outlines the aux pins on Connector J11 for preset settings associated with fan speed and damper position found in **Factory Settings > Unit Options**.

Table 6 - Aux Presets

Presets	Aux 1	Aux 2	Aux 3
Normal Operation (Selected Blower Mode)			
Fan Speed/Damper Position 1	X		
Fan Speed/Damper Position 2		X	
Fan Speed/Damper Position 3	X	X	
Fan Speed/Damper Position 4			X
Fan Speed/Damper Position 5	X		X
Fan Speed/Damper Position 6		X	X
Fan Speed/Damper Position 7	X	X	X

- Fan Proving Config** - The exhaust contactor must be set to Before Airflow or After Airflow. When enabled, the user may set the number of contactors used. Contactor 1 = Aux 2, Contactor 2 = Aux 3.
 - Enable** - When enabled, a fault detected will display when not operating.
 - Retry** - When enabled, the unit will try to automatically reset upon airflow proving failure. After a second failed attempt, a manual reset will be required.
 - # Contactors** - Number of exhaust fan contactors.
 - Exh Fan** - If exhaust contactor fails proving, while "Exh Fan" is set to On, all fans shut down. When "Exh Fan" is set to Alarm Only, only post proving faults but allow fans to keep running.
- VFD Direction** - Sends a command to the VFD to run in forward or reverse.
- VFD Freq Limits** - Min/Max settings for fan speed.
- VFD Volt Limits** - Min/Max settings for 3rd-party VFDs.
- PWM Rate Limits** - Min/Max settings for fan speed.
- DD Wheel Size** - Selection for wheel size and settings.
 - Size** - This selection is utilized for CFM monitoring. Dual blower models will have a '2' assigned after the wheel size model number.
 - K2 Factor** - Used for supply CFM calculations.
- Constant CFM** - When enabled On, blower will modulate to maintain constant CFM.
 - Max Step** - Modulation adjustment; EC motors = %, VFD = Hertz (HZ).
- Occ Fan Presets** - After the blower has started, the blower setting will use the aux pins to drive the preset occupied value.
- Unocc Fan Presets** - After the blower has started, the blower setting will use the aux pins to drive the preset unoccupied value.
 - Fan Preset Default: 1 = 40Hz, 2 = 50Hz, 3 = 0Hz, 4 = 60Hz, 5 = 0Hz, 6 = 0Hz, 7 = 0Hz.
- Occ PWM Presets** - After the blower has started, the blower setting will use the aux pins to drive the preset unoccupied value.
- Unocc PWM Presets** - Allows user to set unoccupied preset blower speed value.
 - PWM Preset Default: 1 = 80%, 2 = 90%, 3 = 0%, 4 = 100%, 5 = 0%, 6 = 0%, 7 = 0%.
- VFD By Others** - This option will be used when a factory provided Modbus control VFD is not utilized. A start command, as well as a 0-10 V output will be provided to the VFD.
- VFD Current Limit** - This limits the max current to the VFD.



• **Pressure Config**

- **Sensor Range** - Menu is available when any blower pressure or mixing box pressure option is selected.
- **Static PS KP** - Proportionally constant value for static pressure measured in V/sec.
- **Cycle Time** - Cycle time is the time between two consecutive readings.
- **PS Hysteresis** - Percentage band between high and low static set points. This will reduce cycling of blower or damper. Increase this value if the blower speed or damper does not settle into a set point.
- **PS Control Types** - The blower/outdoor air pressure control may be set to monitor Building/Duct pressure.

• **Airflow Proving** - Unit may be set to prove by switch, remote sensor, or onboard sensor.

• **Purge Config**

- **Purge Button** - When the purge button is pressed, the damper will open to max outdoor air and turn on the exhaust contactor, if enabled. Purge Button must be enabled for Dry Mode use.
- **Purge Time** - This is the amount of time that the unit will run the purge process if the user does not stop the purge manually.
- **Purge Speed** - Adjustable between VFD or ECM. Min and Max frequency the fan will run during the purge cycle.

- **Dry Mode Config** - When this option is active (automatically or through manual button press), dry mode will run when:
 - Space Dew Point rises above Space DP set point (SP). Dry mode only.
 - In addition, if Summer Vent is ON, Space Dry Bulb rises above Space Dry Bulb SP and space enthalpy is greater than outside air enthalpy.
 - The unit will go to Dry Mode Discharge when there is a call for heat.
 - Space dew point is the average of the Space RH input with any additional HMI inputs.
 - If OA dew point < Space dew point, the mixing box should go to outdoor air set point. This should override any other mixing box functionality.
 - If OA dew point > Space dew point, the mixing box should go to min OA%.
 - Purge should run until the purge timer expires or the user cancels the purge.
 - **Exhaust** - Enables/disables exhaust contactor during dry mode.
 - **Space DP SP** - Dew point threshold for automatic dry mode activation.
 - **Space DB SP** - Dry bulb threshold for automatic dry mode activation.
 - **Space DP Hyst** - Hysteresis value applied to dew point setting.
 - **Summer Vent** - Dew point activation will enhance with enthalpy activation when set to On.
 - **CTR CTRL** - J29-7 will energize per the selected option.

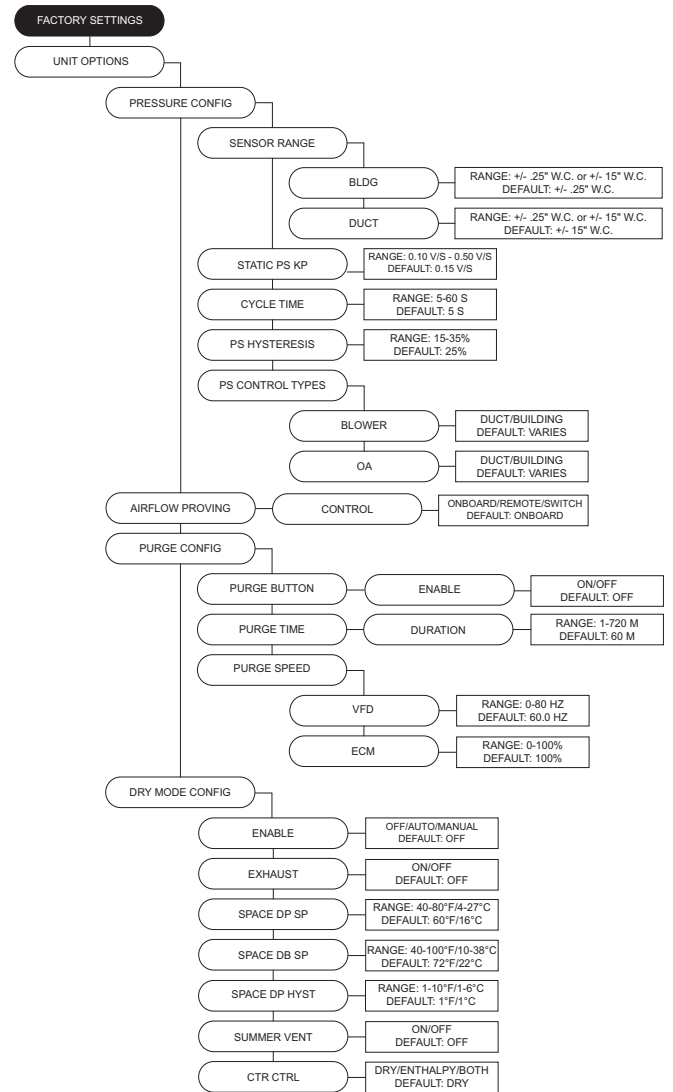

- **Monitoring Sensors** - This menu enables optional components from the factory or when field installed.

- **Smoke Detector** - Enables for smoke detection.
- **Filter Mon** - The option may be set to Off, Contacts or Sensor (J31-14). When set to Contacts or Sensor, if the input is active a fault will be displayed on the HMI.
- **Intake Firestat** - When enabled, if the intake sensor is above the intake firestat set point, the unit will shut down immediately. A manual reset must be performed on the HMI.
- **Discharge Firestat** - When enabled, if the discharge sensor is above the discharge firestat set point, the unit will shut down immediately. A manual reset must be performed on the HMI.
- **Freezestat** - When enabled, if the freezestat sensor trips, the unit will shut down immediately. A manual reset must be performed on the HMI.
- **Freezestat RA** - When the freezestat trips, the unit will go to full return air.
- **Low Gas Switch** - When enabled, if the pressure drops below the threshold heating will shut down.
- **High Gas Switch** - When enabled, if the pressure rises above the threshold heating will shut down.
- **CO Shutdown** - When enabled, if J12-6 reaches 10V, shut down the unit (blower, heating, and cooling).
- **Leak Detector** - Enables A2L sensor.
 - **Source** - Off = no leak detection present, Contactor = 24V DC input, Modbus = Modbus Communication, Either = Contactor or Modbus.
 - **Num MB Devices** - Number of leak detectors communicating via Modbus.
 - **Blower** - When Auto is selected, the blower will run at normal design speed. When Set Value is selected, the blower will run at the set value.
 - **Set Value** - Speed the blower will operate at when a leak is detected.
 - **Damper** - When Auto is selected, the damper will open to normal operating setting. When Set Value is selected, the damper will open to the set value.
 - **Set Value** - Position the damper will open at when a leak is detected.
 - **Heating** - When Auto is selected, heating will run at normal operation. When Off, heating will immediately shut off and not operate if a leak is detected.
 - **Exhaust** - When Auto is selected, powered exhaust will run at normal operation. When Off, powered exhaust will immediately shut off and not operate if a leak is detected.
 - **Set Value** - Speed the power exhaust will operate at when a leak is detected.

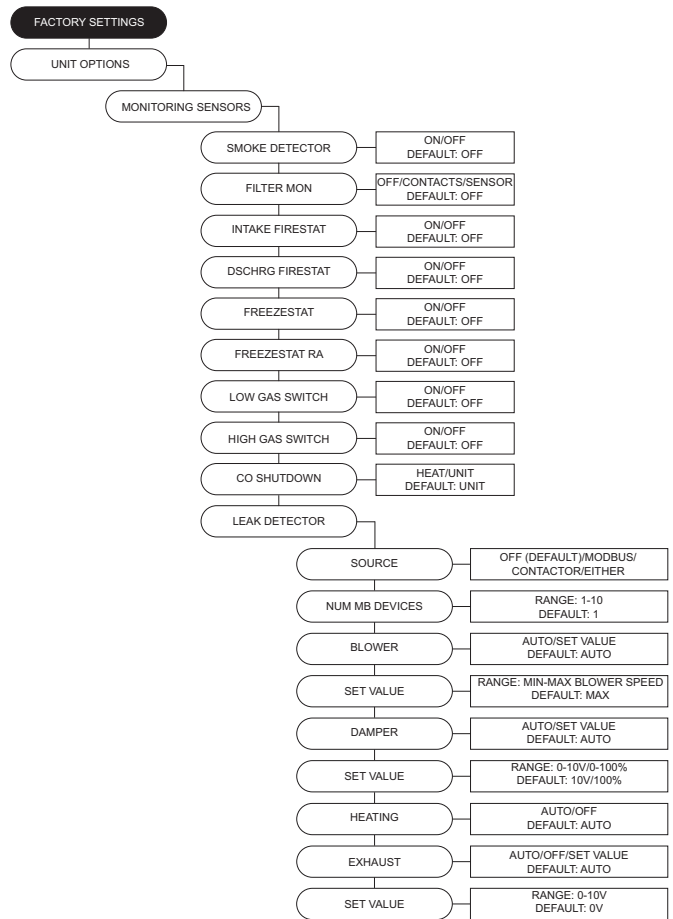

- **High Duct PS Config** - When enabled, if the duct pressure is greater than the set point for longer than the set time, heating/cooling will shut down. A fault will be displayed on the HMI.
 - **Time** - Setting for how long the unit can be outside of its pressure range.
 - **PS Lim** - Duct pressure alarm set point.
 - **Bldg PS Config** - When enabled, if the building pressure is lower/greater than the set point for longer than the set time, heating/cooling will shut down. A fault will be displayed on the HMI.
 - **Time** - Setting for how long the unit can be outside of its pressure range.
 - **Low PS Lim** - Low pressure alarm set point.
 - **High PS Lim** - High pressure alarm set point.
 - **Weighted Avg Temp** - Averages Temperature
 - **Weighted Avg RH** - Averages Relative Humidity
 - **Weighted Avg CO2** - Averages CO2
 - **Weighted Avg PS** - Averages Pressure
- When Weighted settings are enabled On, weight (WT) and lock (LK) adjustments are active. Use WT to assign Space priority monitoring. Use LK when you want specific WT assignments on certain HMIs.

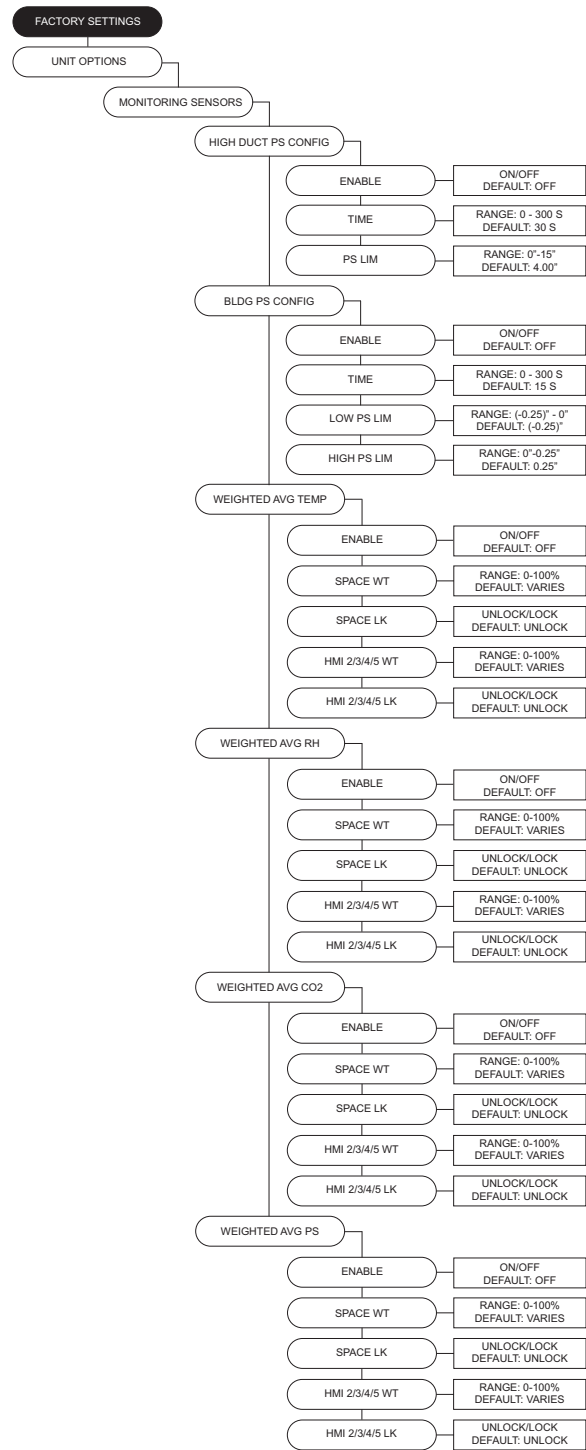

• Mixing Box Config

- **Mixing Box** - Settings for mixing box.
- **Mixing Box Deadband** - If the temperature difference between the outdoor and return sensor is less than or equal to this set point, the MUA Board will not attempt to adjust the output voltage until it matches the outdoor air percentage set point. This setting only takes effect when either outdoor air % or schedule is selected.
- **Return As Space** - Setting this to On will not require a space sensor or HMI. This setting will use the return air thermistor (RT) in place of the space sensor.
- **Off Position** - User may select how the dampers will be positioned when the supply fan is off. Standard (default), Max Outdoor Air %, or Min Outdoor Air %.
- **Mixing Box Limits** - Minimum/maximum settings for mixing box. Percentage or voltage based on mixing box selection.
- **Preset OA Values** - If set to On, the voltage values equivalent to air percentage. Based on percentage of movement to the mixing box damper. No value may be the same.
- **Edit OA% Table** - User may edit voltages for the equivalent to outdoor air percent table.
- **Damper Presets** - This allows the user to set damper preset option On or Off.
- **Preset Volts** - Aux pins control damper actuator.
- **Occ/Unocc Preset Volts** - When scheduling is On, Occ/Unocc Preset Volts will be available.
- **Intake Damper** - On/Off option for intake damper.
- **Discharge Damper** - On/Off option for discharge damper.
- **Room Override** - Uses room override SP rather than Discharge SP. This setting will only have an effect when the heat tempering mode setting is discharge and activate based on is not set to intake.
- **Exhaust Contactor** - This allows the user to assign a contactor for an interlocked exhaust fan. There are occupied and unoccupied settings.
 - **None**
 - **Before airflow** - Exhaust fan will start before the airflow proving switch has been activated.
 - **After airflow** - Exhaust fan will start after the airflow proving switch has proved there is airflow.
- **Exhaust On Smoke** - When enabled On, if it receives a 24VAC signal from a fire system, this will shut down the supply fan and enable the exhaust contactor. The 24VAC signal must originate from the MUA Board.
 - **Damper** - When Outdoor Air Control is set to manual = Volts. When Outdoor Air Control is not set to manual = Percentage. If powered exhaust on fire is enabled, powered exhaust on fire will override the damper position setting.
- **Exhaust Speed Ref** - When enabled On, the exhaust speed will match supply blower VFD.
- **Cabinet Heater** - This allows the user to enable the cabinet heater, if applicable. If enabled, the temperature sensor on MUA Board controls the cabinet heater. When this option is enabled, to adjust set points, go to **User Settings > Temp Set Points > Option Set Points > Cab Heat Set Points**.

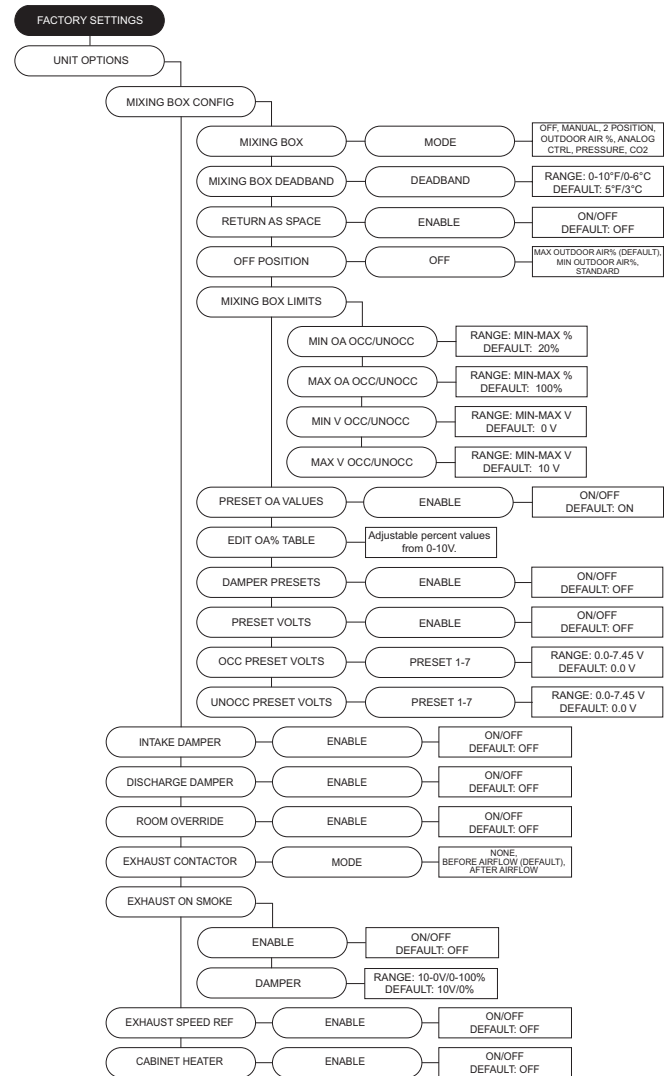

- **Blower Throttle** - The throttle function is to maintain profile pressure across the burner.
- **Throttle Volt Step** - Increases/decreases fan speed when a third party VFD is used.
- **Proof of Closure** - For gas valves that contain a proof of closure switch, the user may set this option On. Before heating occurs, a 24V AC input must be present at connector J32 pin 12.
- **No FSC Reset** - When this option is set to On, the flame safety control will not reset on a failure to prove flame. If the flame fails, a manual reset is required immediately via the push button or HMI.
- **Warm Liquid Bypass** - Prevents freezing of condensing coil in low ambient temperatures.
- **Trouble Input**
 - **Mode** - If connector J28 pin 3 receives 24 volts, the unit will act based on mode setting:
 - **Unit Off** - Shuts down blower (heating/cooling will also shutdown). Bypass any timers.
 - **Both Off** - Turns off/lockout heating and cooling. Bypass min on/off timers.
 - **Heat Off** - Turns off/lockout heating.
 - **Cool Off** - Turns off/lockout cooling. Bypass min On/Off timers.
 - **Set Back** - Forces unit to unoccupied state.
 - **Time** - Setting for off/lockout time.
- **CO2 Control Config** - Monitors CO2 and will adjust blower speed/damper position depending on CO2 set point.
 - **Override** - The unit will try to maintain space CO2 Parts Per Million (PPM) levels based on min/max threshold set points set by the user. The unit will modulate the blower/damper linearly between their corresponding min/max settings.
 - **Threshold** - CO2 Parts Per Million (PPM) maximum threshold set points for the space. When the space CO2 PPM reading exceeds the threshold setting, the blower/damper will go to their max setting.
- **Outdoor Reset** - Allows access to setting option On/Off. Below are scenarios for Outdoor Reset functionality.
 - Discharge Heat Tempering: If outside air is below OA Reset Low set point, heat will discharge to Reset Heat Discharge setting.
 - Space Heat Tempering: If outside air is below OA Reset Low set point, the space set point will adjust to Reset Heat Space setting.
 - Intake Cool Tempering: If outside air is above OA Reset High set point, cooling will go to max staging. If both evap and dx are present, unit will run all.
 - Intake Space Cool Tempering: If outside air is below OA Reset Low set point, space set point will adjust to Reset Cool Space setting.

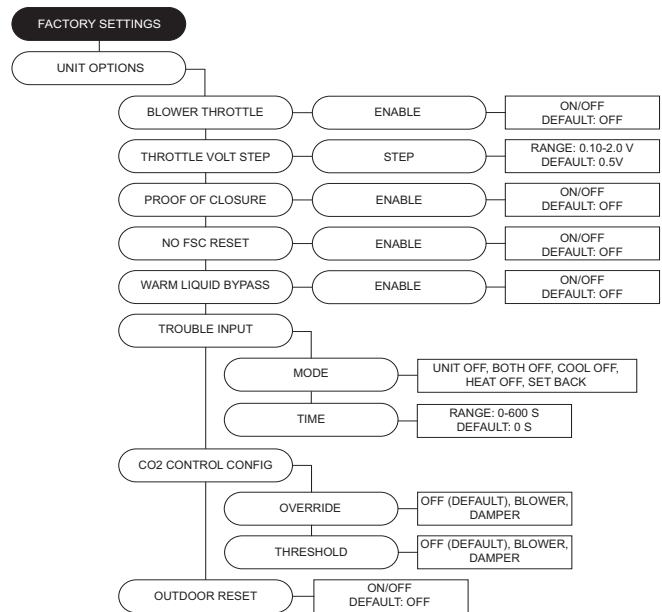

- **Dynamic Set Point** - Dynamic functionality. For heating, every multiple of the Dynamic Set Point Differential would multiply the effect of the Dynamic Offset setting.

- When heating: If the measured outside air temperature is below the Dynamic Heat OA set point minus the differential set point, the space or discharge set point will increase by the offset setting.
- If the measured outside air temperature is above the Dynamic Heat OA set point plus the differential set point, the space or discharge set point will decrease by the offset setting.
- When cooling: If the measured outside air temperature is below the Dynamic Cool OA set point minus the differential set point, the space or discharge set point will increase by the offset setting.
- If the measured outside air temperature is above the Dynamic Cool OA set point plus the differential set point, the space or discharge set point will decrease by the offset setting.

- **Single Zone VAV** - When set to blower, damper, or both, adjustable set points are located in User Settings.
- **Invert** - Normal operation, the blower/damper will go to max settings. Inverse operation, the blower/damper will go to min settings.

- **Alarm Output** - User may set to All or Fireeye. If All is selected, output will energize when any fault occurs. If Fireeye is selected, output will energize when Fireeye faults occur. Connector J30 pin 8 will be energized.

- **Pool Room** - Option for pool room applications.
 - **Pool Room DP SP** - When above the dew point setpoint (SP), the blower will modulate to the pool room's blower speed setting.
 - **PR Blower Speed** - Blower speed adjustment for high dew point pool rooms.
 - **PR DP Hyst** - Hysteresis value applied to dew point SP.

- **Unit Performance** - Adjustable points for monitoring. For service settings, go to **Service > Unit Performance**.
 - **CFM** - Design CFM
 - **Min/Max Duct SP** - Design duct static pressure.
 - **Min/Max Bldg SP** - Design building static pressure.
 - **Mtr Eff** - Motor Efficiency.
 - **BHP** - Brake Horsepower.
 - **D Freq** - Design Frequency.
 - **D ECM** - Design Percentage.

Occ OvrD Duration - Length of override timer. If override is active, it can be manually stopped by pressing the end override button on the HMI.

Limit SP Adjust - This allows the user to change the current temperature set point through the home screen. The range adjustment is 0-100 degrees. When the set point is set to 0°F, the adjustment buttons (+/-) will not be visible.

Temp OvrD Duration - Length of temperature override timer.

PID Parameters - (DO NOT CHANGE PARAMETERS)

Sensor Offsets - Offset adjustment for Discharge, Space, and Intake sensor parameter settings.

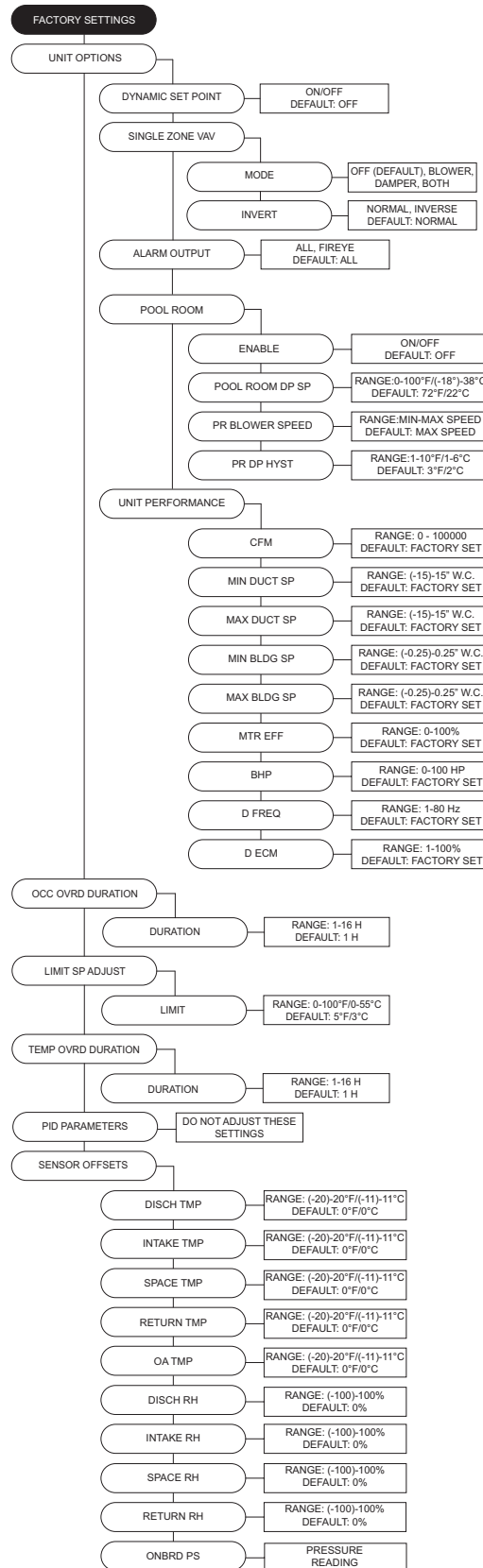

Service

Job Info - Non-editable parameters. Displays Job #, Unit #, HMI #, Tag (HMI Name e.g, Office/Hallway/Break Room) entered at the factory.

Temperatures - Monitor various temperature values.

Relative Humidity - Current humidity readings per HMI.

CO2 Values - Monitoring for various CO2 values.

Pressure Values - Monitoring for various Pressure values.

Open/Closed Status - Open/closed status of all inputs.

Variable Values - Monitor variable input and output values.

VFD Status - Monitor VFD parameters.

High Temp Limit - Displays the high temp limit.

Airflow Limits - Displays the high/low airflow limits.

Mixing Box Values - Monitor mixing box values.

Unit Performance - Compares **Unit Options > Unit Performance** to current unit's operational values.

- **Dsn CFM** - Design CFM. Job specific unit CFM.
- **Act CFM** - Actual CFM. Current unit CFM reading.
- **Min/Max Dsn D SP** - Design duct static pressure. Job specific external static pressure.
- **Min/Max Dsn B SP** - Design building static pressure. Job specific external static pressure.
- **Act D SP** - Actual duct static pressure. Current external static pressure.
- **Act B SP** - Actual building static pressure. Current external static pressure.
- **Act BHP** - Actual Brake Horsepower.
- **Mtr Delta** - Motor Delta. Temperature rise caused by motor heat.
- **MHG** - Motor Heat Gain. BTU rise caused by motor heat.
- **HT Cap** - Heating capacity output in MBH.
- **HT KW** - Heating output in kilowatts.

Test Menu - When in a testing state, you must set the 'State' back to OFF to cancel the test.

- **Test Fans** - All, Supply, Exhaust.
- **Test Heating** - Contains high/low fire tests for stages. If "Heating Config" is set to 0, then "No Heat Stage Set" will display. Allows blower and damper modulation.
 - In test mode, the high limit setting will be based on intake temp + max temp rise + 10 degrees or the unit's high limit setting, whichever is higher.
 - If mixing box is On, set to 0V or 100% OA.
 - Exiting test mode will reset the PID.
- **Test Cooling** - Test cooling or heat pump system. Also, monitors cooling system specifications. Allows blower and damper modulation.
- **Test High Temp Limit** - Test menu allows user to set limit to simulate a high temp fault.
- **Test Options**
 - **Test Cabinet Heater** - Activates the cabinet heater on.
 - **Test Drain Heater** - Activates the drain heater to on.
 - **Test Mixing Box** - This test will create an output to the outdoor air control. The test will begin at 0 volts. The up/down buttons allow for modulation.
 - **Test Freezestat** - Access to adjust set points to verify freezestat operation in different ambient conditions.

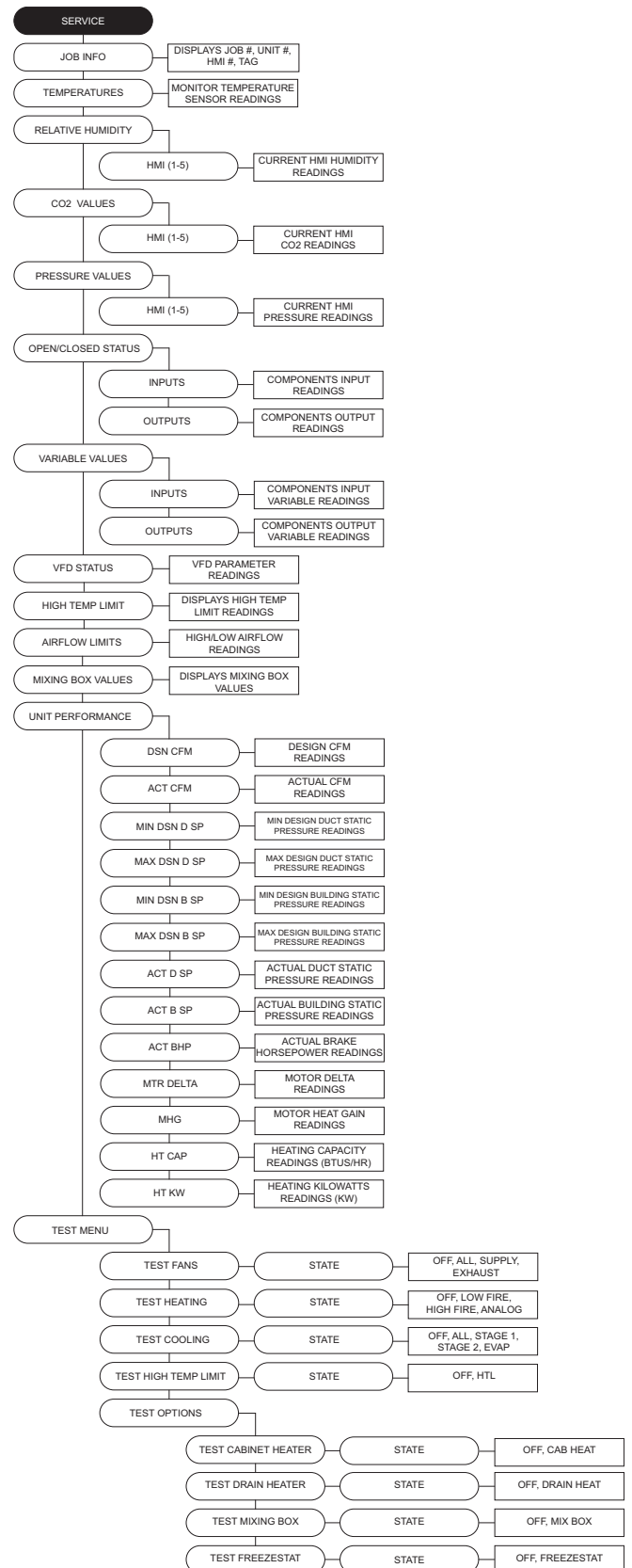

Clear Fault History - Clears entire fault history. If a fault is active when cleared, that fault will show up until it is fixed.

Set Clock - Adjustment for Day and Time settings.

Calibrate Onboard PS - Calibrates onboard pressure sensor. Must disconnect all pressure tubes before calibration.

Calibrate Mixing Box - Calibration process to update factory default values to building site conditions.

Reset MB To Defaults - Mixing box values reset to defaults.

Calibrate Filter PS - Calibrates clogged filter pressure. Must disconnect all pressure tubes before calibration.

Calibrate PS1 - Calibrates static pressure sensor input at connector J31 pin 17. Must disconnect all pressure tubes before calibration.

Calibrate PS2 - Calibrates static pressure sensor input at connector J16 pin 1. Must disconnect all pressure tubes before calibration.

Calibrate Supply CFM - Calibrates pressure differential in the venturi to calculate approximate fan CFM. Must disconnect all pressure tubes prior to calibration.

Supply CFM - Displays measured CFM readings. This readout is only valid for units with direct-drive wheels.

Update Factory Defaults (DFLTS) - Allows original factory default settings to be overridden. Confirming the updated settings will now be used during a "Factory Reset."

Factory Reset - Confirming will reset to factory saved defaults, or last saved updated factory defaults.

QR Codes

CASLink - Provides access to CASLink webpage. The user will need an account to log in to see informations.

Parts - Provides access to the online parts store for parts available for product groups on the job number.

Filters - Provides access to the online parts store for available filters for product groups on the job number.

Technical Resources - Provides access to the online resources page for technical documentation.

Technical Support - Provides access to the service page for Technical Support.

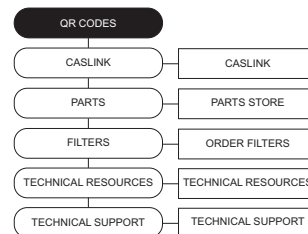
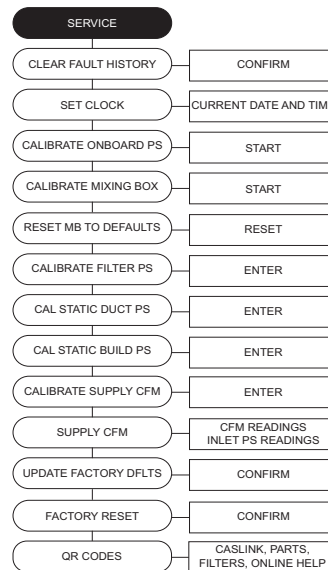

Unit Options

Communication Module (Optional)

The Communication Module, PN: **SCADA**, is included in all CASlink equipped panels. It obtains operational data from various connected components. This communication wiring is either RS-485 shielded twisted pair wiring or RJ45 Cat 5 Ethernet wiring.

Building Signal Damper Control

When this option is ordered, the outdoor air (supply) and return dampers will modulate based on a 0-10V DC signal from the Building automation system. 0V = max outside air, 10V = max return air. Direct fired units cannot go below 20% outside air, maximum output voltage may differ.

Electric Cabinet Heater

Units can be shipped with an optional 120V electric cabinet heater powered from the MUA Board. There is a temperature sensor built onto the MUA Board that will regulate when the cabinet heater activates. To enable this option go to **Factory Settings > Unit Options > Cabinet Heater > Enable**. Temperature readings and adjustments can be made through the HMI. Go to **User Settings > Temp Set Points > Option Set Points > Cab Heat Set Points**.

Motorized Intake Damper

On units shipped with the optional motorized intake damper, a power transformer is supplied with the unit if the main incoming voltage is greater than 120V. No external wiring to the damper motor is required.

Mixing Box Control Unit Options

Manual Control - The dampers can be controlled from the HMI in the unit or from a space HMI if one is provided to any position from 20% to 100% fresh air. This is a 0-10V setting, which is available under user settings, 100% Outdoor Air (0 volts), 80% Return Air (equivalent voltage). This will allow to manually set the dampers to match the building ventilation requirements. On a power failure, the return air damper will close by spring return.

Two Position Control - The dampers can be controlled by a two-position switch (a field-supplied switching device) to open the fresh air to 100%. The MUA Board sends out a constant voltage. The field supplied switch will cut or allow the signal from the MUA Board to the mixing box damper. On opening of the circuit, power failure, or if the unit is shut off, the return air damper will close by spring return. If the circuit is closed, the MUA Board will allow the return air damper to open per the set point.

Outdoor Air % - The dampers can be controlled from the HMI in the unit or from a space HMI if one is provided to any position from 20% to 100% fresh air. There is an outdoor air percentage setting that is available under user settings. This will allow the user to manually set the dampers to match the building ventilation requirements.

- When preset OA is On, the unit will use preset values for mixing box OA% by directly associating OA voltage to OA percentages. A calibration can be run from the service menu to store and use real-world results rather than provided defaults.
- When preset OA is Off, the MUA Board utilizes an internal algorithm to alter its 0-10V output to the mixing box damper in order to maintain an exact outdoor air percentage. When this mixing box option is selected, a mixing box dead-band comes into play. This setting checks the delta T between outdoor and return air. If the difference between these two temperatures is less than or equal to the mixing box dead-band setting, the MUA Board will not alter its output to the mixing box damper (default setting is 5 degrees). On a power failure, or if the unit is turned off, the return air damper will close by spring return.

Analog Control - When this is set to ON, a 0-10V input will drive the damper output to modulate linearly between the min and max OA voltage for both occupied and unoccupied modes.

Static Pressure Control - Damper position will modulate to maintain building pressure. Building pressure below the set point will increase the amount of outdoor air supplied to increase pressure. Building pressure above the set point will decrease the amount of outdoor air supplied to decrease pressure.

CO2 Control - When the unit senses the CO2 input to be above the threshold setting, the unit will decrease mixing box output until the CO2 falls below threshold setting.

Variable Frequency Drive (VFD)

WARNING!

- Before installing the VFD drive, ensure the input power supply to the drive is OFF.
- The power supply and motor wiring of the VFD must be completed by a qualified electrician.
- The VFD is factory programmed, only change if replaced or ordered separately.

Not suitable for corner grounded 3 phase input power. Consult the VFD manual and all documentation shipped with the unit for proper installation and wiring of the VFD. The VFD has been programmed by the factory with ordered specific parameters. Refer to **Table 7** during installation.

Table 7 - VFD Installation Check List

Check Off	Description
	The installation environment conforms to the VFD manual.
	The drive is mounted securely.
	Space around the drive meets the drive's specification for cooling.
	The motor and driven equipment are ready to start.
	The drive is properly grounded.
	The input power voltage matches the drive's nominal input voltage.
	The input power connections at L1, L2, and L3 are connected and tight. Input power must always be wired to the input L terminal connections (L1, L2, L3).
	The input power protection is installed.
	The motor power connection at U, V, and W are connected and tight.
	The input, motor, and control wiring are run in separate conduit runs.
	The control wiring is connected and tight.
	NO tools or foreign objects (such as drill shavings) are in the drive.
	NO alternative power source for the motor (such as a bypass connection) is connected - NO voltage is applied to the output of the drive.

Variable Frequency Drive (VFD) Installation

Input AC Power

- Circuit breakers feeding the VFDs are recommended to be thermal-magnetic and fast-acting. They should be sized based on the VFD amperage and according to “**VFD Part Number/Specifications**” on page 55. Refer to the installation schematic for exact breaker sizing.
- Every VFD should receive power from its own breaker. If multiple VFDs are to be combined on the same breaker, each drive should have its own protection measure (fuses or miniature circuit breaker) downstream from the breaker.
- Input AC line wires should be routed in conduit from the breaker panel to the drives. AC input power to multiple VFDs can be run in a single conduit if needed. **Do not combine input and output power cables in the same conduit.**
- The VFD should be grounded on the terminal. Check for a terminal marked PE or GND Symbol. A separate insulated ground wire must be provided to each VFD from the electrical panel. This will reduce the noise being radiated in other equipment.

ATTENTION: Do not connect incoming AC power to output terminals U, V, W. Severe damage to the drive will result. Input power must always be wired to the input L terminal connections (L1, L2, L3).

VFD Output Power

- Motor wires from each VFD to its respective motor **MUST** be routed in a **separate steel** conduit away from control wiring and incoming AC power wiring. This is to avoid noise and crosstalk between drives. An insulated ground must be run from each VFD to its respective motor. Do not run different fan output power cables in the same conduit.
- VFD mounted in fan: The load reactor should be sized accordingly when the VFD is mounted in the fan.
 - 208/230V** - Load reactor is optional but recommended for 15 HP and above motors.
 - 460/480V** - Load reactor is optional but recommended for 7.5 HP and above motors.
 - 575/600V** - Load reactors are required for all HP motors.
- Do not install a contactor between the drive and the motor. Operating such a device while the drive is running can potentially cause damage to the power components of the drive.
- When a disconnect switch is installed between the drive and motor, the disconnect should only be operated when the drive is in a STOP state.
- VFDs should not be powered through a Ground Fault Circuit Interrupter (GFCI) breaker/outlet. Unnecessary and intermittent tripping may occur.

SMV VFD Programming

1. The Drive should be programmed for the proper motor voltage.
 - P107 is set to 0 (Low) if motor voltage is 120V AC, 208V AC or 400V AC. P107 is set to 1 (High) if the motor voltage is 230V AC, 480V AC, or 575V AC.
2. The Drive should be programmed for the proper motor overload value. Refer to **“VFD Part Number/ Specifications” on page 55**.
 - P108 is calculated as Motor FLA x 100 / Drive Output Rating.

To access the SMV parameters:

1. Use the buttons on the VFD screen to adjust VFD settings (**Figure 24**). Press the Mode (M) button. This will activate the password prompt (PASS).
2. Use the Up and Down buttons to scroll to the password value (the factory default password is “0225”) and press the Mode (M) button. Once the correct password is entered, the display will read “P100”, which indicates that the PROGRAM mode has been accessed at the beginning of the parameter menu.
3. Use the Up and Down buttons to scroll to the desired parameter number.
4. Once the desired parameter is found, press the Mode (M) button to display the present parameter setting. The parameter value will begin blinking, indicating that the present parameter setting is being displayed. The value of the parameter can be changed by using the Up and Down buttons.
5. Pressing the Mode (M) button will store the new setting and exit the PROGRAM mode. To change another parameter, press the Mode (M) button again to re-enter the PROGRAM mode. If the Mode button is pressed within 1 minute of exiting the PROGRAM mode, the password is not required to access the parameters. After one minute, the password must be re-entered to access the parameters again.

P500 parameter provides a history of the last 8 faults on the drive. It can be accessed without entering PROGRAM mode.

Figure 24 - SMV VFD Screen

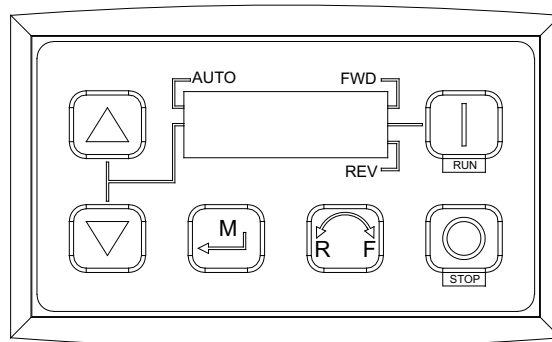

i500 VFD Programming

1. The Drive should be programmed for the proper motor voltage.
 - **i500 Drives:** P208.01 will be set to [0] for 208V/230V, [2] for 460V or 480V, [3] for 120V, and [6] for 575V or 600V. If your voltage value is not listed, set to the nearest voltage of P208.01. For example: If your input voltage is 220V, set to [0]. If your input voltage is 110V, set to [3].
2. The Drive should be programmed for the proper motor overload value. Refer to **“VFD Part Number/ Specifications” on page 55.**
 - **i500 Drives:** P308.01 will be set to 150%.

To access the i500 parameters:

1. If the i500 does not have a keypad, find and insert the keypad module into the VFD.
2. Use the buttons on the VFD screen to adjust VFD settings (**Figure 25**).
3. Press Enter to access the menus. Use the Up and Down arrows to enter the password. Press Enter.
4. Use the arrow keys to find the group required (0-8). Press Enter. The first number of the parameter indicates the parameter’s group (except for Group 0). For example: Parameter P220.00 is in Group 2, P510.01 is in Group 5, etc.
5. Use the arrow keys to find the parameter required. Press Enter. For example: P220.00 which is in Group 2.
6. Check the value of the parameter. Only change this value if necessary.
7. Once the new value is set, press Enter to save the value.

Figure 25 - i500 VFD Screen

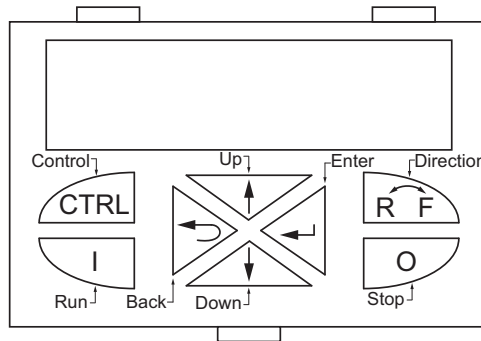

For troubleshooting i500 Series Drives, refer to **“VFD Fault List” on page 75.**

VFD Part Number/Specifications

Table 8 - Cross-Reference

HP	SMV Part Number	i500 Part Number	Volts	1Ø Input	3Ø Input	Input Amps 1Ø 120V AC	Input Amps 1Ø 240V AC	Output Amps	Breaker 1Ø 120V AC	Breaker 1Ø 240V AC
0.5	ESV371N01SXB571	i51BP137A0000ACBSS	120/240V	X	-	9.2	4.6	2.4	15	15
1	ESV751N01SXB571	i51BP175A0000ACBSS	120/240V	X	-	16.6	8.3	4.2	25	15
1.5	ESV112N01SXB571	i51BP211A0000ACBSS	120/240V	X	-	20	10	6	30	20

HP	Part Number	i500 Part Number	Volts	1Ø Input	3Ø Input	Input Amps 1Ø	Input Amps 3Ø	Output Amps	Breaker 1Ø	Breaker 3Ø
0.5	ESV371N02YXB571	i51BP137D0000ACBSS	240V	X	X	5.1	2.9	2.4	15	15
1	ESV751N02YXB571	i51BP175D0000ACBSS	240V	X	X	8.8	5	4.2	15	15
1.5	ESV112N02YXB571	i51BP211D0000ACBSS	240V	X	X	12	6.9	6	20	15
2	ESV152N02YXB571	i51BP215D0000ACBSS	240V	X	X	13.3	8.1	7	25	15
3	ESV222N02YXB571	i51BP222D0000ACBSS	240V	X	X	17.1	10.8	9.6	30	20
5	ESV402N02TXB571	i51BP255C0000ACBSS (7.5 HP)	240V	-	X	-	18.6	16.5	-	30
7.5	ESV552N02TXB571		240V	-	X	-	26	23	-	40
10	ESV752N02TXB571	i55AP275C0030ACBSS	240V	-	X	-	33	29	-	50
15	ESV113N02TXB571	i55AP311C0030ACBSS	240V	-	X	-	48	42	-	80
20	ESV153N02TXB571	i55AP315C0030ACBSS	240V	-	X	-	59	54	-	90
480V										
1	ESV751N04TXB571	i51BP175F0000ACBSS	480V	-	X	-	2.5	2.1	-	15
1.5	ESV112N04TXB571	i51BP211F0000ACBSS	480V	-	X	-	3.6	3	-	15
2	ESV152N04TXB571	i51BP215F0000ACBSS	480V	-	X	-	4.1	3.5	-	15
3	ESV222N04TXB571	i51BP222F0000ACBSS	480V	-	X	-	5.4	4.8	-	15
5	ESV402N04TXB571	i51BP240F0000ACBSS	480V	-	X	-	9.3	8.2	-	15
7.5	ESV552N04TXB571	i51BP255F0000ACBSS	480V	-	X	-	12.4	11	-	20
10	ESV752N04TXB571	i51BP275F0000ACBSS	480V	-	X	-	15.8	14	-	25
15	ESV113N04TXB571	i55AP311F0031ACBSS	480V	-	X	-	24	21	-	40
20	ESV153N04TXB571	i55AP315F00301CBSS	480V	-	X	-	31	27	-	50
25	ESV183N04TXB571	i55AP318F00301CBSS	480V	-	X	-	38	34	-	70
30	ESV223N04TXB571	i55AP322F00301CBSS	480V	-	X	-	45	40	-	80
40	ESV303N04TXB571	i55AP330F00301CBSS	480V	-	X	-	59	52	-	100
50	ESV373N04TXB571	i55AP337F00801CBSS	480V	-	X	-	74	65	-	125
60	ESV453N04TXB571	i55AP345F00801CBSS	480V	-	X	-	87	77	-	150
600V										
1	ESV751N06TXB571	i51BP175G00*0ACBSS	600V	-	X	-	2	1.7	-	15
2	ESV152N06TXB571	i51BP215G00*0ACBSS	600V	-	X	-	3.2	2.7	-	15
3	ESV222N06TXB571	i51BP222G00*0ACBSS	600V	-	X	-	4.4	3.9	-	15
5	ESV402N06TXB571	i51BP240G00*0ACBSS	600V	-	X	-	6.8	6.1	-	15
7.5	ESV552N06TXB571	i51BP255G00*0ACBSS	600V	-	X	-	10.2	9	-	20
10	ESV752N06TXB571	i51BP275G00*0ACBSS	600V	-	X	-	12.4	11	-	20
15	ESV113N06TXB571	i55AP311G0030ACBSS	600V	-	X	-	19.7	17	-	30
20	ESV153N06TXB571	i55BP315G0030ACBSS	600V	-	X	-	25	22	-	40
25	ESV183N06TXB571	i55BP318G0030ACBSS	600V	-	X	-	31	27	-	50
30	ESV223N06TXB571	i55BP322G0030ACBSS	600V	-	X	-	36	32	-	60
40	ESV303N06TXB571	i55BP330G0030ACBSS	600V	-	X	-	47	41	-	70
50	ESV373N06TXB571	i55BP345G00701CBSS (60 HP)	600V	-	X	-	59	52	-	90
60	ESV453N06TXB571		600V	-	X	-	71	62	-	110

START-UP OPERATION

Before starting up or operating the unit, verify all fasteners are secure and tight. Check the set screw in the wheel hub. With power and gas **OFF** to the unit or before connecting the unit to power, turn the fan wheel by hand. Verify it is not striking the inlet or any obstructions. If necessary, re-center.

Special Tools Required: Standard Hand Tools, AC Voltage Meter, Tachometer, Amperage Meter, Manometer, Differential Pressure Gauge

Unit Start-up Procedure

1. Check all electrical connections are secure and tight.
2. For belt drive units, check pulley alignment and belt tension. Refer to “**Pulley Alignment/Proper Belt Tension**” on page 58.
3. Inspect the condition of the intake damper and damper linkage, if applicable.
4. Remove intake filters if not already installed, inspect the air stream for obstructions. Install intake filters.
5. Compare the supplied **motor voltage** with the fan’s nameplate voltage. If this does not match, correct the problem.
6. Place the external disconnect to the **ON** position to start the unit. Immediately place the disconnect switch off. **Check the rotation of the fan** with the directional arrow on the blower scroll. Reversed rotation will result in poor air performance, motor overloading and possible burnout. For units equipped with a single-phase motor, check the motor wiring diagram to change rotation. For 3-phase motors, any two power leads can be interchanged to reverse motor direction.
7. When the fan is started, observe the operation and check for any unusual noises.
8. Place the external disconnect switch back to the **ON** position. The system should be in full operation with all ducts attached. Measure the system airflow.
9. Once the proper airflow is achieved, measure and record the fan speed with a reliable tachometer. **Caution - Excessive speed will result in motor overloading or bearing failure. Do not set fan RPMs higher than specified in the maximum RPM chart.** Refer to “**TROUBLESHOOTING**” on page 70 for more information.
10. Measure and record the **voltage** and **amperage** to the motor. Compare with the motor’s nameplate to determine if the motor is operating under safe load conditions.

Pulley Adjustment

The adjustable motor pulley is factory set for the RPM specified (**Table 9**). Speed can be increased by closing or decreased by opening the adjustable motor sheave. Two groove variable pitch pulleys must be adjusted to an equal number of turns open or closed. Any increase in speed represents a substantial increase in horsepower required by the unit. Motor amperage should always be checked to avoid serious damage to the motor when the speed is varied. Always torque set screws according to the torque specifications shown in **Figure 26**.

Figure 26 - Adjustable Pulley

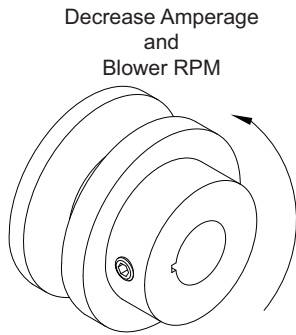

Setscrew Thread Size	Torque (in-lbs)
No. 10 (bushing)	32
1/4" (bushing)	72
5/16"	130

Table 9 - Maximum RPM and HP Chart

Blower Size	Max. RPM	Max. HP
10"	1800	2
12"	1500	3
15"	1400	5
18"	1200	5
20"	1000	10
25"	900	20

Pulley Alignment/Proper Belt Tension

- Belts tend to stretch and settle into pulleys after an initial start-up sequence. **Do not tension belts by changing the setting of the motor pulley**, this will change the fan speed and may damage the motor.
 - To re-tension belts, turn OFF power to the fan motor.
 - Loosen all fasteners that hold the blower motor plate to the blower housing.
 - Rotate the motor to the left or right to adjust the belt tension. Belt tension should be adjusted to allow 1/64" of deflection per inch of belt span. Use extreme care when adjusting V-belts as not to misalign pulleys. Any misalignment will cause a sharp reduction in belt life and produce squeaky noises. Over-tightening will cause excessive belt and bearing wear as well as noise. Too little tension will cause slippage at start-up and uneven wear.
 - Whenever belts are removed or installed, never force belts over pulleys without loosening motor first to relieve belt tension.** When replacing belts, use the same type as supplied by the manufacturer. On units shipped with double groove pulleys, matched belts should always be used.
- All fasteners should be checked for tightness each time maintenance checks are performed before restarting unit.

Belt tension examples:

- Belt span 12" = 3/16" deflection
- Belt span 32" = 1/2" deflection

Figure 27 - Pulley Alignment/Belt Tension

- A. Belt Span Length
- B. Deflection
- C. Center Distance

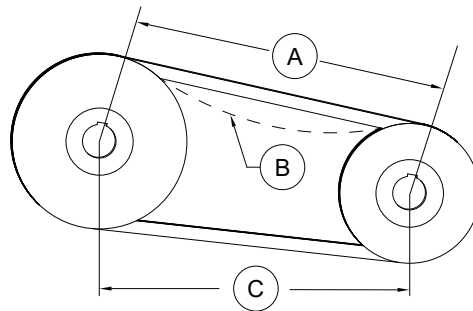

Correct

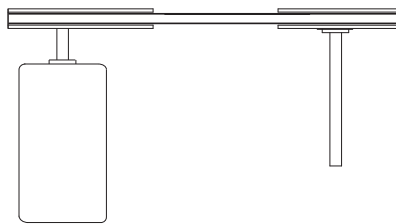

Incorrect

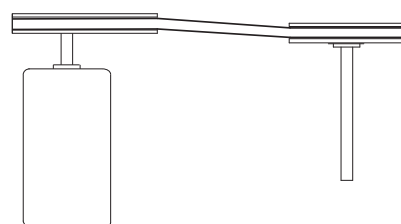

Incorrect

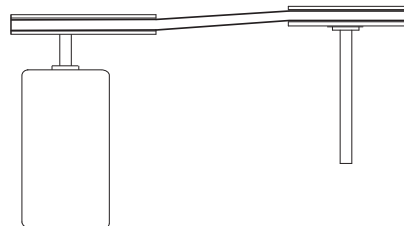

Incorrect

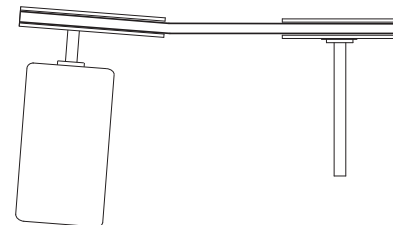

Pulley Combination Chart

Motor RPM			1725													
10 - 20 IN. BLOWER **	1/3 to 1-1/2 HP AX BELTS			MOTOR PULLEY 1VL34		Dd1	Dd2	Pd1	Pd2							
				Open		TURNS ON MOTOR PULLEY										Closed
	BLOWER PULLEY	DATUM DIAMETER	PITCH DIAMETER	5	4 1/2	4	3 1/2	3	2 1/2	2	1 1/2	1	1/2	0		
	AK114	11	11.2	308	323	339	354	370	385	400	416	431	447	462		
	1/3 to 2 HP AX BELTS			MOTOR PULLEY 1VL40		Dd1	Dd2	Pd1	Pd2							
				Open		TURNS ON MOTOR PULLEY										Closed
	BLOWER PULLEY	DATUM DIAMETER	PITCH DIAMETER	5	4 1/2	4	3 1/2	3	2 1/2	2	1 1/2	1	1/2	0		
	AK114	11	11.2	400	416	431	447	462	477	493	508	524	539	554		
	AK94	9	9.2	488	506	525	544	563	581	600	619	638	656	675		
	AK79	7.5	7.7	582	605	627	650	672	694	717	739	762	784	806		
	AK66	6.2	6.4	701	728	755	782	809	836	863	889	916	943	970		
	AK54	5	5.2	863	896	929	962	995	1028	1062	1095	1128	1161	1194		
	AK46	4.2	4.4	1019	1059	1098	1137	1176	1215	1255	1294	1333	1372	1411		
	AK39	3.5	3.7	1212	1259	1305	1352	1399	1445	1492	1539	1585	1632	1678		
	AK32	3	3.2	1402	1455	1509	1563	1617	1671	1725	1779	1833	1887	1941		
3 to 5 HP BX BELTS			MOTOR PULLEY 2VP42		Dd1	Dd2	Pd1	Pd2								
			Open		TURNS ON MOTOR PULLEY										Closed	
BLOWER PULLEY	DATUM DIAMETER	PITCH DIAMETER	6	5 1/2	5	4 1/2	4	3 1/2	3	2 1/2	2	1 1/2	1	1/2	0	
2BK160H	15.4	15.7	330	339	348	357	366	375	385	394	403	412	421	430	439	
2BK140H	13.4	13.7	378	388	399	409	420	430	441	451	462	472	483	493	504	
2BK120H	11.4	11.7	442	455	467	479	491	504	516	528	541	553	565	577	590	
2BK110H	10.4	10.7	484	497	511	524	537	551	564	578	591	605	618	631	645	
2BK100H	9.4	9.7	534	548	563	578	593	608	622	637	652	667	682	697	711	
2BK90H	8.4	8.7	595	611	628	644	661	677	694	710	727	744	760	777	793	
2BK80H	7.4	7.7	672	691	709	728	747	765	784	803	821	840	859	877	896	
2BK70H	6.4	6.7	772	794	815	837	858	880	901	923	944	965	987	1008	1030	
2BK60H	5.4	5.7	908	933	958	984	1009	1034	1059	1084	1110	1135	1160	1185	1211	
2BK55H	4.9	5.2	995	1023	1050	1078	1106	1133	1161	1189	1216	1244	1272	1299	1327	
2BK50H	4.4	4.7	1101	1132	1162	1193	1223	1254	1285	1315	1346	1376	1407	1438	1468	
7-1/2 to 10 HP BX BELTS			MOTOR PULLEY 2VP60		Dd1	Dd2	Pd1	Pd2								
			Open		TURNS ON MOTOR PULLEY										Closed	
BLOWER PULLEY	DATUM DIAMETER	PITCH DIAMETER	6	5 1/2	5	4 1/2	4	3 1/2	3	2 1/2	2	1 1/2	1	1/2	0	
2BK160H	15.4	15.7	516	527	538	549	560	571	582	593	604	615	626	637	648	
2BK140H	13.4	13.7	592	604	617	630	642	655	667	680	693	705	718	730	743	
2BK120H	11.4	11.7	693	708	722	737	752	767	781	796	811	826	840	855	870	
2BK110H	10.4	10.7	758	774	790	806	822	838	854	871	887	903	919	935	951	
2BK100H	9.4	9.7	836	854	871	889	907	925	943	960	978	996	1014	1031	1049	
2BK90H	8.4	8.7	932	952	972	991	1011	1031	1051	1071	1091	1110	1130	1150	1170	
2BK80H	7.4	7.7	1053	1075	1098	1120	1143	1165	1187	1210	1232	1255	1277	1299	1322	
25 IN. BLOWER	3 to 5 HP BX BELTS			MOTOR PULLEY 2VP42		Dd1	Dd2	Pd1	Pd2							
				Open		TURNS ON MOTOR PULLEY										Closed
	BLOWER PULLEY	DATUM DIAMETER	PITCH DIAMETER	6	5 1/2	5	4 1/2	4	3 1/2	3	2 1/2	2	1 1/2	1	1/2	0
	2B5V278	27.8	28.1	184	189	194	200	205	210	215	220	225	230	235	240	246
	2B5V250	25	25.3	205	210	216	222	227	233	239	244	250	256	261	267	273
	2B5V234	23.4	23.7	218	224	230	237	243	249	255	261	267	273	279	285	291
	2B5V200	20	20.3	255	262	269	276	283	290	297	304	312	319	326	333	340
	2B5V184	18.4	18.7	277	284	292	300	307	315	323	331	338	346	354	361	369
	2B5V160	16	16.3	317	326	335	344	353	362	370	379	388	397	406	414	423
	2B5V154	15.4	15.7	330	339	348	357	366	375	385	394	403	412	421	430	439
	2B5V136	12.6	12.9	401	412	423	435	446	457	468	479	490	501	513	524	535
	2B5V124	12.4	12.7	407	419	430	441	453	464	475	487	498	509	521	532	543
	2B5V110	11	11.3	458	471	483	496	509	522	534	547	560	572	585	598	611
	7-1/2 to 10 HP BX BELTS			MOTOR PULLEY 2VP60		Dd1	Dd2	Pd1	Pd2							
				Open		TURNS ON MOTOR PULLEY										Closed
BLOWER PULLEY	DATUM DIAMETER	PITCH DIAMETER	6	5 1/2	5	4 1/2	4	3 1/2	3	2 1/2	2	1 1/2	1	1/2	0	
2B5V278	27.8	28.1	289	295	301	307	313	319	325	331	338	344	350	356	362	
2B5V250	25	25.3	320	327	334	341	348	355	361	368	375	382	389	395	402	
2B5V234	23.4	23.7	342	349	357	364	371	378	386	393	400	408	415	422	429	
2B5V200	20	20.3	399	408	416	425	433	442	450	459	467	476	484	493	501	
2B5V184	18.4	18.7	434	443	452	461	470	480	489	498	507	517	526	535	544	
2B5V160	16	16.3	497	508	519	529	540	550	561	571	582	593	603	614	624	
2B5V154	15.4	15.7	516	527	538	549	560	571	582	593	604	615	626	637	648	
2B5V136	12.6	12.9	628	642	655	669	682	695	709	722	735	749	762	776	789	
2B5V124	12.4	12.7	638	652	666	679	693	706	720	733	747	761	774	788	801	
2B5V110	11	11.3	717	733	748	763	779	794	809	824	840	855	870	885	901	
15 to 20 HP BX BELTS			MOTOR PULLEY 2VP75		Dd1	Dd2	Pd1	Pd2								
			Open		TURNS ON MOTOR PULLEY										Closed	
BLOWER PULLEY	DATUM DIAMETER	PITCH DIAMETER	6	5 1/2	5	4 1/2	4	3 1/2	3	2 1/2	2	1 1/2	1	1/2	0	
2B5V278	27.8	28.1	381	387	393	399	405	411	417	424	430	436	442	448	454	
2B5V250	25	25.3	423	430	436	443	450	457	464	470	477	484	491	498	505	
2B5V234	23.4	23.7	451	459	466	473	480	488	495	502	509	517	524	531	539	
2B5V200	20	20.3	527	535	544	552	561	569	578	586	595	603	612	620	629	
2B5V184	18.4	18.7	572	581	590	600	609	618	627	636	646	655	664	673	683	
2B5V160	16	16.3	656	667	677	688	698	709	720	730	741	751	762	773	783	
2B5V154	15.4	15.7	681	692	703	714	725	736	747	758	769	780	791	802	813	
2B5V136	12.6	12.9	829	842	856	869	883	896	909	923	936	949	963	976	990	

** 2HP Motors on 20 IN Blowers use 2VP42 Pulleys

Components

The following image and list outline the typical direct fired heater components and their functions.

Figure 28 - Typical Cabinet Components

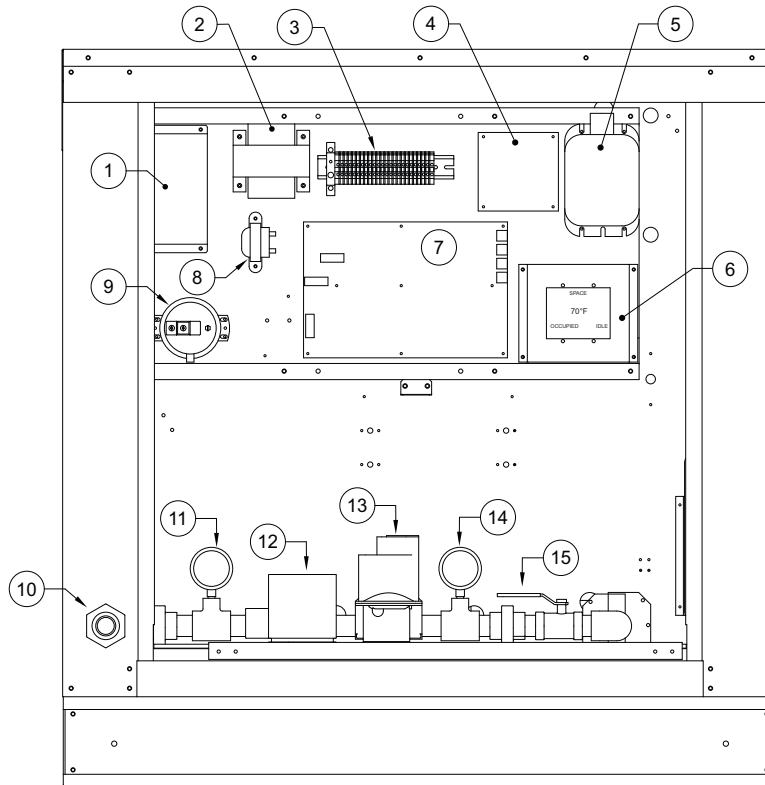

1. **VFD** – Optional component. Adjusts speed of 3-phase motors by changing the frequency signal sent to the motor.
2. **Power Transformer** – Optional component. Installed when motor voltage is greater than 120V. Used to provide 120V service to controls.
3. **Terminal Strip** – Central location to terminate control wiring. Should be used for troubleshooting.
4. **Flame Safety Control** – Initiates and monitors flame.
5. **Ignition Transformer** – Produces high voltage spark to ignite flame.
6. **HMI (Human Machine Interface)** – The 4 buttons are used to navigate through the menu screens.
7. **MUA (Make-Up Air) Board** – Monitors and outputs electrical signals for components and functions on the unit. Also, the MUA Board contains an airflow sensor.
8. **Transformer** – 20VA 120V to 24V.
9. **Clogged Filter Switch** – Optional component. Senses whether the filters at the intake to the main supply motor are free of dirt and contaminant.
10. **Gas Inlet** – Main gas supply connection.
11. **Inlet Gas Pressure Gauge** – Inlet gas pressure should be read from here.
12. **Combination Gas Valve** – A combination of redundant solenoid valves, pilot valve, and gas regulator built into one unit.
13. **Modulating Gas Valve** – Modulates gas flow to the burner to provide proper air temperature.
14. **Manifold Gas Pressure Gauge** – Manifold gas pressure should be read from here.
15. **Manual Gas Shut-Off Valve** – Allows gas flow to the burner to be shut off to leak-test gas train.

Sequence of Operation

There are two main systems, a make-up air fan and a heater. The make-up air fan consists of a blower and motor. The heater may be broken down into two control systems, the Flame Safety Control (FSC) and the Modulating Gas System (MGS). The burner mixes air with the gas (Natural or LP), which heats the air.

Flame Safety Control

The FSC is there **only** to monitor the flame, **NOT** to control the temperature. The FSC uses a flame rectification sensor mounted on the pilot assembly to detect the presence of flame in the burner.

Flame strength and presence can be measured at the FSC by reading the rectified flame signal. Use a DC voltage meter, attach meter leads to the test jacks (TP1 and TP2) on the top edge of the FSC. Flame is present when DC voltage reads between 6 and 18V DC. Ideal flame intensity produces a signal of 12V DC or higher. Flame signal may also be read on the HMI by entering **Service > Variable Values > Inputs > Flame Sensor**.

The board monitors the flame signal voltage at connector J32 pin 6 (+) and 15 (-). The FSC receives an airflow signal from the MUA Board, which tells it whether there is proper airflow through the unit (not *just* any airflow, but *proper* airflow). Proper airflow occurs when there is a 0.15" wc to 0.80" wc differential pressure drop across the burner.

When the airflow through the heater produces differential pressure in this range, the FSC indicates so by illuminating the AIRFLOW LED. The FSC controls the opening of the redundant solenoid gas valves and the operation of the spark igniter to initiate a pilot flame upon start-up.

Figure 29 - Flame Safety Controller

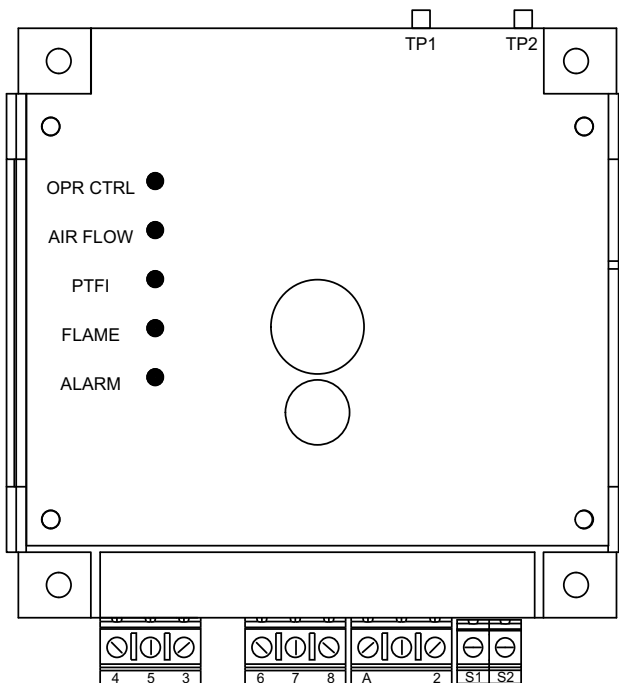

DC Voltage	Flame Status
0 to 5V DC	No Flame
6 to 11V DC	Weak Flame
12 to 18V DC	Strong Flame

TP1 and TP2 = Flame Sensor Voltage Test Jacks

Pin 1 = N/A

Pin 2 = 120V AC Neutral from MUA Board

Pin 3 = 120V AC Pilot Gas Output to MUA Board

Pin 4 = 120V AC Spark Output to MUA Board

Pin 5 = 120V AC Main Gas Output to MUA Board

Pin 6 = 120V AC Input from MUA Board

Pin 7 = 120V AC Input from MUA Board

Pin 8 = N/A

Pin A = 120V AC Alarm Output to MUA Board

S1 = Ground Connection

S2 = Flame Rod Connection

The **OPR CTRL** LED indicates that there is power to the FSC. Next, the **AIRFLOW** LED will come on if there is proper airflow through the unit. Third, the unit will pause to purge any gases or combustible vapors before attempting flame ignition. Then, there is a Pilot Trial For Ignition (PTFI), and the **PTFI** LED comes on. During PTFI, the FSC opens the pilot gas valve and allows gas to flow to the pilot assembly. At the same moment, the spark igniter is started, causing the spark to ignite the pilot gas. When the flame rod sensor detects the flame, it turns on the **FLAME** LED, turns off the PTFI LED, and powers the modulating gas system. This is the system's normal operating mode. The FSC continues to monitor the flame and airflow. Once this occurs, the unit is in the main flame cycle and thus powers the main gas valve and the modulating gas system. This is the normal operating mode. The FSC continues to monitor the flame and airflow.

The last LED on the FSC is the **ALARM** LED. The alarm will turn on when the FSC determines an unsafe condition has occurred and will not allow the unit to recycle for heat until it has properly been reset. Anytime the FSC goes into "Alarm" mode, the issue must be diagnosed and corrected to avoid further lockouts after resetting. If the unit fails to light the first time, the unit will try one more time before locking out. This retry will not occur if the No FSC reset option is enabled. To begin troubleshooting, or to reset the FSC, refer to "**Resetting Unit**" on page 75.

Figure 30 - Proper Spark Gap

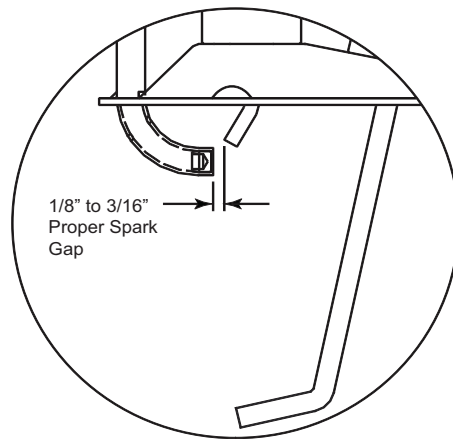

Modulating Gas System

The Maxitrol Modulating Gas System is directly controlled from the MUA (Make-Up Air) Board at connector J32 pin 7(+) and 16(-). A modulating 0-24V DC signal is utilized to modulate the gas valve signal. The signal is a 16 kHz full-wave rectified signal.

The RTC Modulating Gas System is directly controlled from the MUA Board at connector J7 pin 6. A modulating 2-10V DC signal is utilized to modulate the gas valve signal.

The Modulating Gas System consists of an Intake Temp Sensor, a Discharge Temp Sensor, a Space Temp Sensor (only on space temperature control options), and modulating gas valve(s). The intake air sensor, the space sensor, or a combination of the two can be used to give a call for heat signal to the MUA Board.

The MUA board uses a PID loop and checks the difference between the temperature sensor readings in order to modulate the heat appropriately.

- For kitchen MUA heating applications, intake air set point should be set at 45°F, whereas the discharge set point should be set at 55°F. The defaults may be adjusted per field conditions.
- For all other applications, the set point should be set appropriately based on end-user preferences and on-site conditions.

High Temperature Limit

One of the backup safety devices is the high-temperature limit lockout. This temperature sensor measures the temperature inside the unit, downstream of the burner. If the factory-set temperature of 170°F is exceeded, it will signal the FSC to turn off the burner. This requires a manual reset of the high-temperature limit. Refer to “Resetting Unit” on page 75.

Pilot Adjustment

1. Restart the fan and check the gas supply pressure at the inlet gas gauge upstream of all electronic valves. The inlet pressure should be **7 - 14 inches wc (7 inches wc - 5 psi on Size 4-5 heaters)**. If the inlet pressure is too high, install an additional pressure regulator external to the unit.
2. Open the field-installed manual gas shut-off valve.
3. Close the ball valve located inside the cabinet.
4. Call for heat using the HMI **Service > Test Menu > Test Heating > High Fire**. If the pilot does not light, purge the pilot line. If air purging is required, disconnect the pilot line at the outlet of the pilot valve.
5. Check the **pilot flame voltage** on the HMI. The voltage reading should be **12V-15V DC**. The Flame LED on the Flame Safety Controller should be illuminated too. A weak pilot flame can be caused by low gas pressure or a dirty pilot orifice.
6. To adjust the pilot flame, remove the cap from the pilot adjustment screw on the combination gas valve, refer to **Figure 12**. Increase the pilot gas flow by turning the screw counter-clockwise. Decrease the pilot gas flow by turning the screw clockwise. The flame signal voltage should read **12V-15V DC** on the HMI under **Service > Test Menu > Test Heating**.
7. Once the pilot has been established, open the main manual gas shut-off valve downstream of the electronic valves. Verify the main gas valve opens and gas flows to the burner.

Figure 31 - Pilot Assembly

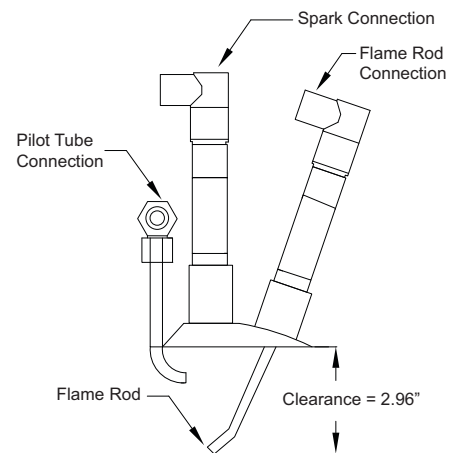

Main Burner Adjustment (Maxitrol Valve)

- Once the pilot has been properly established, the manifold gas pressure or temperature rise should be adjusted to nameplate or design specifications. The gas pressure regulator is adjusted at the factory for average gas conditions. It is important that the gas supplied to the burner is in accordance with the input rating on the rating plate. Refer to **“Gas Train” on page 15**.
 - For size 1-3 heaters, the gas pressure regulator is integral to the combination gas valve.
 - For size 4-5 heaters, the gas pressure regulator is located on the modulating valve.
- Use the service test menu to lock the unit in high fire: **Service > Test Menu > Test Heating > State > High Fire**. Press Enter.
- The manifold pressure should be checked at the pressure gauge downstream of the modulating valve. **Figure 34 on page 66** indicates the proper manifold pressure for the desired amount of BTUs per foot of burner. For natural gas systems, the high fire manifold pressure should not exceed **5 inches wc**. For propane gas, the high fire manifold pressure should not exceed **2.5 inches wc**. Another method of checking high fire is to measure the temperature rise of the unit. The temperature rise should be set to design specifications and typically is minimum 70°F.
- Every unit has a specific design manifold gas pressure based on CFM and temperature rise. Refer to the unit's nameplate for the design manifold gas pressure.
- For size 1-3, remove the cap from the combination gas valve for regulator adjustment. For size 4/5, remove the cap from the modulating valve (location #1 **Figure 12**).
- Use the regulator pressure adjusting screw to adjust the high fire manifold pressure to design temperature rise (**5 inches wc** maximum for natural gas and **2.5 inches wc** maximum for propane gas). High fire should be set to generate the design temperature rise. If the high fire screw is at the end of its adjustment and more pressure is needed, then adjust the main building gas pressure regulator spring (located external to the unit) to achieve the proper manifold pressure. Turning the regulator screw clockwise will increase pressure and counter-clockwise will decrease pressure. **Remember - The high fire DC voltage should read 12V-18V on the HMI.**
- Use the service test menu to lock the unit in low fire: **Service > Test Menu > Test Heating > State > Low Fire**. Press Enter.
- Verify that the unit is in low fire by confirming the voltage to the modulating valve is 0V DC.
- Locate the bypass screw (under the cap of the valve - location #1, or side of the modulating valve - location #2), refer **Figure 12**.
- Adjust the low fire manifold pressure until there is a very thin flame along the entire length of the burner. No dark spots should be seen in the burner. If the flame is too large at low fire, this will decrease the unit's turndown ratio.
- The burner may be observed through the view-port located on the external wall of the heater. Replace the cap to the valve. Make sure all wiring and gas components are connected and operational.
- A final gas leak check shall be performed to verify the gas-tightness of the heater's components and piping under normal operating conditions. This can be done by measuring the gas pressure at the 1/4" gas plug just downstream of the modulating valve.

Figure 32 - High/Low Fire Bypass Screw Setting

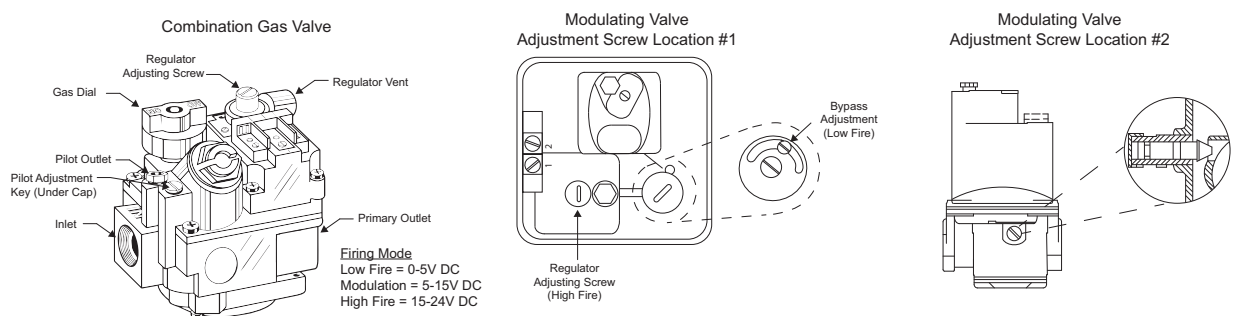

Main Burner Adjustment (RTC Valve)

1. Once the pilot has been properly established, the manifold gas pressure or temperature rise should be adjusted to nameplate or design specifications. The gas pressure regulator is adjusted at the factory for average gas conditions. It is important that the gas supplied to the burner is in accordance with the input rating on the rating plate. Refer to **“Gas Train” on page 15**. For size 1-3 heaters, the gas pressure regulator is integral to the combination valve.
2. Use the service test menu to lock the unit in high fire: **Service > Test Menu > Test Heating > State > High Fire**. Press Enter.
3. The manifold pressure should be checked at the pressure gauge downstream of the modulating valve. **Figure 34 on page 66** indicates the proper manifold pressure for the desired amount of BTUs per foot of burner. For natural gas systems, the high fire manifold pressure should not exceed **5 inches wc**. For propane gas, the high fire manifold pressure should not exceed **2.5 inches wc**. Another method of checking high fire is to measure the temperature rise of the unit. The temperature rise should be set to design specifications and typically is minimum 70°F.
4. Every unit has a specific design manifold gas pressure based on CFM and temperature rise. Refer to the unit’s nameplate for the design manifold gas pressure.
5. For size 1-3, remove the cap from the combination gas valve for regulator adjustment.
6. Use the regulator pressure adjusting screw to adjust the high fire manifold pressure to design temperature rise (**5 inches wc** maximum for natural gas and **2.5 inches wc** maximum for propane gas). High fire should be set to generate the design temperature rise. If the high fire screw is at the end of its adjustment and more pressure is needed, then adjust the main building gas pressure regulator spring (located external to the unit) to achieve the proper manifold pressure. Turning the regulator screw clockwise will increase pressure, and counter-clockwise will decrease pressure.
7. Use the service test menu to lock the unit in low fire: **Service > Test Menu > Test Heating > State > Low Fire**. Press Enter.
8. Verify that the unit is in low fire by confirming the voltage to the modulating valve is 2V DC.
9. Go to **Factory Settings > Heating Config > Gas Valve Limits > Min%** to adjust the low fire voltage.
10. Adjust the low fire manifold pressure until there is a very thin flame along the entire length of the burner. No dark spots should be seen in the burner. The burner may be observed through the view-port located on the external wall of the heater. Make sure all wiring and gas components are connected and operational.
11. A final gas leak check shall be performed to verify the gas-tightness of the heater’s components and piping under normal operating conditions. This can be done by measuring the gas pressure at the 1/4” gas plug just downstream of the modulating valve.

Figure 33 - RTC Modulating Gas Valve

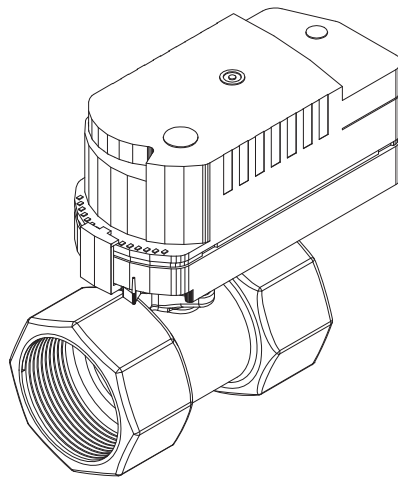
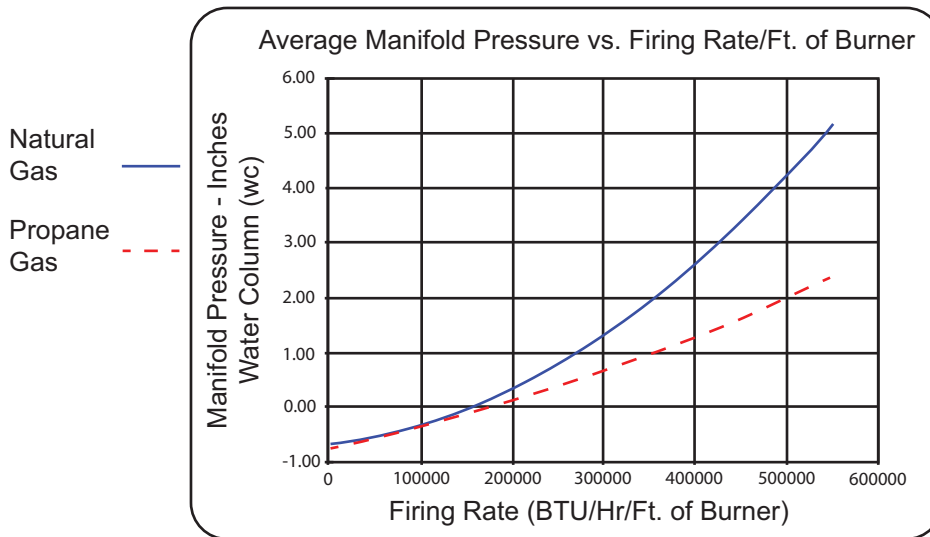

Figure 34 - Pressure vs. Firing Rate



Final Start-up Procedure

1. With the air and burner systems in full operation and all ducts attached, measure the system airflow. The motor sheave (pulley) is variable pitch and allows for an increase or decrease of the fan RPM. For belt drive units, if an adjustment is needed, refer to “**Pulley Adjustment**” on page 57. Reference **Table 9** on page 57 and “**Pulley Combination Chart**” on page 59 for adjustment specifications.
2. Once the proper airflow is achieved, measure and record the fan speed with a reliable tachometer. **Caution - Excessive speed will result in motor overloading or bearing failure. Do not set fan RPMs higher than specified in the maximum RPM chart.** See the troubleshooting guide for more information.
3. Measure and record the **voltage** and **amperage** to the motor and compare with the motor nameplate to determine if the motor is operating under safe load condition.
4. For belt drive units, once the RPM of the wheel has been properly set, disconnect power. Recheck belt tension and pulley alignment. Refer to “**Pulley Adjustment**” on page 57.

Airflow Sensor

The MUA Board contains an onboard pressure sensor (**Figure 35**) for airflow monitoring. There are both high and low **airflow tubing connections** connected to a sensor, measuring the pressure drop across the burner. This is to verify that there is proper airflow (**0.15 to 0.80 inch wc**) across the burner and proper combustion at all times.

There are two airflow tubes in the heater, located near the burner and profile plate assembly (profile plates surround the burner and control air into the burner section).

In the case of a broken belt, clogged filters, blocked intake, excessive duct or static pressure, the correct burner differential pressure may not be achieved. This will prevent the low airflow sensor to close. The airflow sensor protects against profile plate failures that cause excessive airflow through the burner. In the event that the pressure drop across the burner is not in the range of the airflow sensor, gas flow to the burner is stopped by the Flame Safety Control.

NOTE: With the blower running, verify the airflow pressure reading is a positive value. Reverse the airflow tubes if the reading is negative.

To view burner profile pressure on the HMI, go to **Service > Variable Values > Inputs > Onbd Prof PS**.

Figure 36 illustrates the approximate CFM going through the unit vs. the differential pressure measured by the airflow switch. Simply measure the differential profile pressure drop at the airflow tubes in the unit and match that value up to the unit curve. This will show the CFMs traveling through the burner and will indicate proper airflow or airflow problems (too much or not enough).

Figure 35 - Board Airflow Sensor

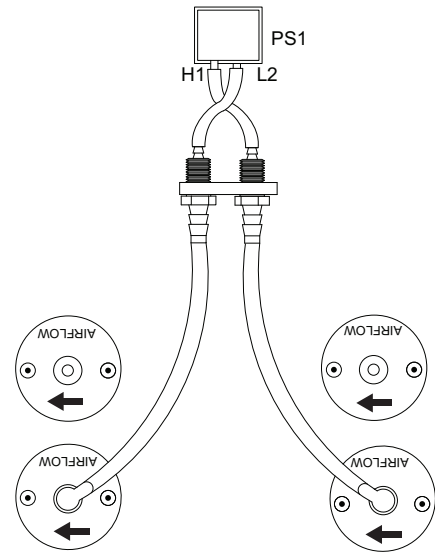
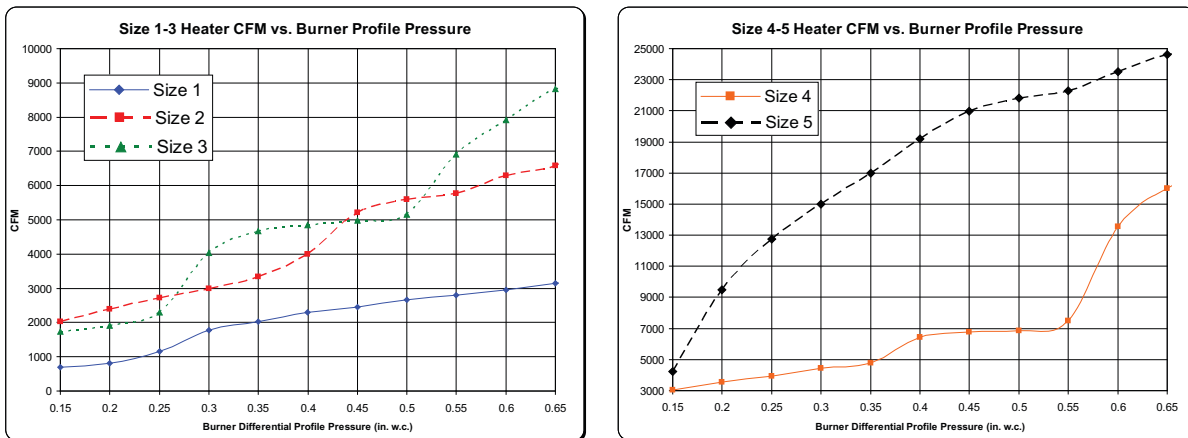

Figure 36 - CFM Chart



Static Pressure Sensor Installation

For indoor mounted units using pressure control, the A-306 kit (**Figure 37**) should be used for sensing outside pressure. Use the installation instructions shipped with the sensor kit for installation guidance.

Figure 37 - A-306 Sensor

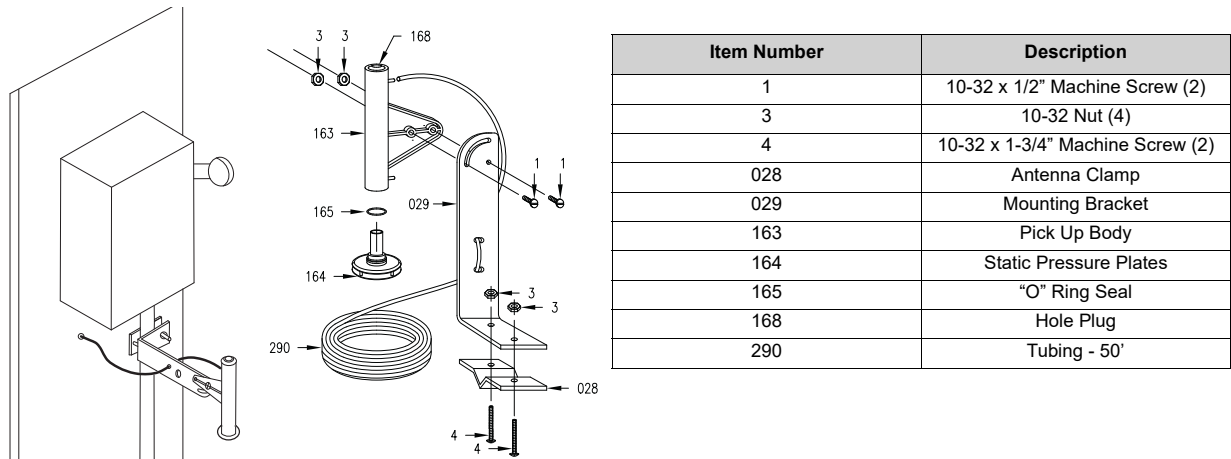

Component Check/Testing

Clogged Filter Switch (PS-10)

- The vent tube should be connected to the low side port (**Figure 38**). A fault will occur when the switch senses a negative pressure.
- If the "Clogged Filters" fault is active:
 - Check the filters. If the filters are clogged or damaged, replace as needed. Check for any other obstructions in the unit.
 - Verify the electrical connections are secure and tight. Verify vent tube is not pinched or damaged.
 - When the unit is powered ON:
 - There should be **24-28V AC** at connector J13 pin 5 to ground. If the voltage reading is incorrect, check the wiring harness and voltage at the circuit board.
 - There should be **0V AC** at connector J13 pin 12 to ground. If there is voltage at pin 12, check the adjustment of the switch.

Clogged Filter Switch Field Adjustment

Follow these steps if performing a part replacement, or to calibrate the switch.

- Install the switch. Install the vent tube on the low side port.
- Install the electrical connections. Power the unit ON. Set dampers to 100% open for outdoor air. Monitor the HMI screen.
- Use a screwdriver to turn the adjustment screw clockwise until it is completely seated in the switch. Use material suitable to block 50-75% of the intake from the outside of the unit.

Turn the adjustment screw counter-clockwise in one turn increments (waiting 3 seconds per adjustment) until the "Clogged Filters" fault is active. Turn the adjustment screw a 1/4 to 1/2 turn clockwise until the fault is no longer active.

Figure 38 - Clogged Filter Switch

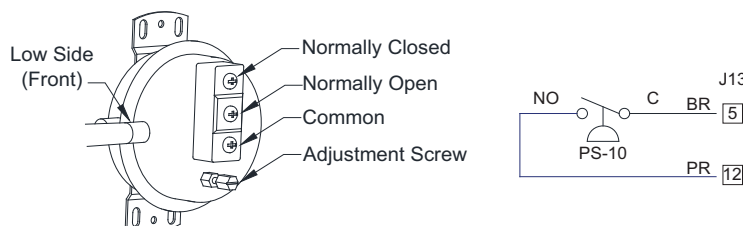

High Gas Pressure Switch (PS-03)

1. Turn the unit ON. Reset the lever on the switch. Gas pressure must be lower in the chamber for the reset latch to be set properly. Verify the high gas pressure switch is set to **12 in. w.c.**
2. Remove the cover. Make sure the wiring is set up for Normally Closed (N.C.) contact (**Figure 39**).
3. Verify the ON/OFF gas valve, and modulating valve are set properly. Refer to “**Gas Train Start-Up Procedure**” on page 57.
4. Check for voltage:
 - Back probe connector J13 pin 4 to ground. There should be **24-28V AC**.
 - Back probe connector J13 pin 11 to ground. There should be **24-28V AC**.
 - If the voltage reading is incorrect, check the wiring for an open or short circuit. If the wiring is correct, the switch has failed. Replace the switch.
 - If the voltage reading is correct, and the switch reset corrected the fault, there may have been an intermittent fault.

Figure 39 - High Gas Pressure Switch

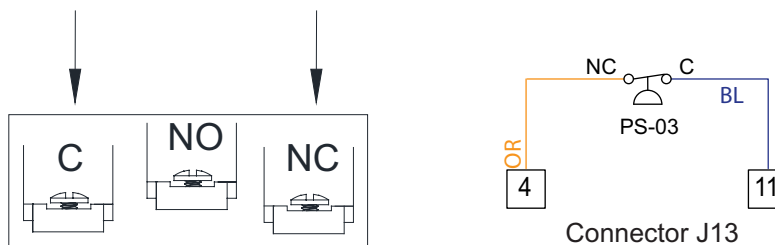

Low Gas Pressure Switch (PS-04)

1. Turn the unit ON. Verify the inlet pressure gauge is reading the correct pressure.
 - Natural gas - **7 in. w.c. – 14 in. w.c.**
 - Propane - **11 in. w.c. – 14 in. w.c.**
- NOTE: If the reading is incorrect, contact the gas supply company.**
2. Reset the lever on the switch. Gas pressure must be higher in the chamber for the reset latch to be set properly. If the reset did not work, continue with the next step.
 3. Remove the cover. Make sure the wiring is set up for Normally Open (N.O.) contact (**Figure 40**).
 4. Check for voltage:
 - Back probe connector J13 pin 3 to ground. There should be **24-28V AC**.
 - Back probe connector J13 pin 10 to ground. There should be **0V AC**.
 - If the voltage reading is incorrect, check the wiring for an open or short circuit. If the wiring is correct, the switch has failed. Replace the switch.
 - If the voltage reading is correct, and the switch reset corrected the fault, there may have been an intermittent fault.

Figure 40 - Low Gas Pressure Switch

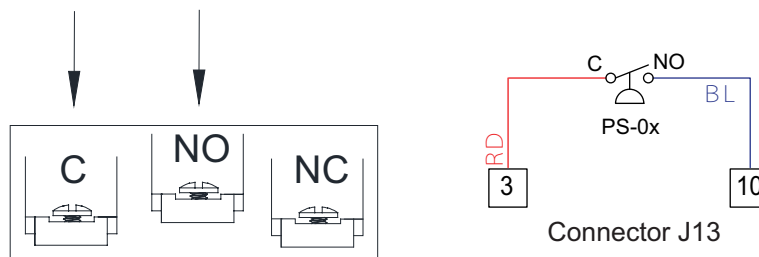

TROUBLESHOOTING

The troubleshooting section lists causes and corrective actions for possible problems with the equipment. Review this section prior to consulting the manufacturer.

Airflow Troubleshooting Chart

Problem	Potential Cause	Corrective Action
Fan Inoperative	Blown fuse/Open circuit breaker	Check amperage.
		Check fuse, replace if needed.
		Check circuit breaker.
	Disconnect switch in "OFF" position	Place switch to the "ON" position.
	Incorrect wiring to motor	Inspect motor wiring. Verify connections with wiring diagram located on fan motor.
Motor starter overloaded	Check amperage.	
	Reset starter.	
Motor Overload	Incorrect fan rotation	Verify that the fan is rotating in the direction shown on rotation label.
	Fan speed is too high	Reduce fan RPM.
	Incorrect wiring to motor	Inspect motor wiring. Verify connections with wiring diagram located on fan motor.
	Overload in starter set too low	Set overload to motor's FLA value.
	Motor HP too low	Determine if HP is sufficient for job.
	Duct static pressure lower than design	Reduce fan RPM.
Insufficient Airflow	Incorrect fan rotation	Verify that the fan is rotating in the direction shown on rotation label.
	Poor outlet conditions	Check duct and connections. There should be a straight duct connection to the outlet.
	Intake damper not fully open	Inspect damper linkage. If the linkage is damaged, replace damper motor.
	Duct static pressure higher than design	Check ductwork. Adjust/resize to eliminate or reduce duct losses.
	Blower speed too low	Increase fan RPM. Do not overload motor.
	Supply grills or registers closed	Open/Adjust.
	Dirty/clogged filters	Clean filters. Replace filters if they cannot be cleaned or are damaged.
Excessive Airflow	Fan speed is too high	Reduce fan RPM.
	Filters not installed	Install filters.
	Duct static pressure lower than design	Reduce fan RPM.
Excessive Vibration and Noise	Damaged/Unbalanced wheel	Replace wheel.
	Fan is operating in unstable region of fan curve	Refer to performance curve for fan.
	Bearings need lubrication/Damaged bearing	Lubricate bearings, replace if damaged.
	Fan speed is too high	Reduce fan RPM.
	Dirty/oily belt(s)	Clean belt(s).
	Belt(s) too loose	Adjust, replace if necessary.
	Worn belt(s)	Replace belt(s).
Misaligned pulleys	Align pulleys.	

Burner Troubleshooting

Problem	Potential Cause	Corrective Action
Pilot Does Not Light/Stay Lit	Main gas is off	Open main gas valve.
	Air in gas line	Purge gas line.
	Dirt in pilot orifice	Clean orifice with compressed air.
	Gas pressure out of range	Adjust to proper gas pressure.
	Pilot valve is off	Turn pilot valve on.
	Leak at pilot orifice	Tighten pilot orifice.
	Excessive drafts	Redirect draft away from unit.
	Safety device has cut power	Check limits and airflow sensor.
	Dirty flame sensor	Clean flame sensor.
	Defective flame rod	Replace flame rod.
	No call for heat	Adjust heat set point.
	No spark at igniter	Check wiring, sensor, and ignition controller. Check spark gap, refer to Figure 30 on page 62 .
Main Burner Does Not Light (Pilot is lit)	Defective valve	Replace combination valve.
	Loose valve wiring	Check wiring to valve.
	Shut-off valve closed	Open shut-off valve.
	Defective flame safety controller	Replace flame safety controller.
	Pilot fails as main gas valve opens, and main gas flows.	Plug the first burner port next to the pilot gas tube with burner cement.
Not Enough Heat	Main gas pressure too low	Increase main gas pressure - do not exceed 14 inches wc inlet pressure (5 PSI on size 4-5 heater).
	Too much airflow	Decrease airflow if possible.
	Burner undersized	Check design conditions.
	Gas controls not wired properly	Check wiring.
	Heat set point too low	Increase heat set point.
	Faulty HMI Sensor	Replace HMI.
	Faulty Discharge Sensor	Check wiring. Replace sensor.
	Unit locked into low fire	Check wiring.
Too much heat	Defective modulating gas valve	Check/replace modulating valve.
	Heat set point too high	Decrease heat set point.
	Unit locked into high fire	Check wiring.
	Faulty HMI Sensor	Replace HMI.
	Faulty Discharge Sensor	Check wiring. Replace sensor.

HMI Fault Codes

Fault	Potential Cause	Corrective Action
Fire Detect	The board is receiving an input from the fire detector.	Possible fire present.
		Check wiring. Repair broken or loose wiring connections.
		Faulty fire detector, replace fire detector.
Smoke Detect	The board is receiving an input from the smoke detector.	Verify the smoke detector functionality.
		Check wiring. Repair broken or loose wiring connections.
		Faulty smoke detector, replace smoke detector.
Supply Overload/ Exhaust Overload	Motor overload has tripped.	Check motor for debris.
		Check contactor/motor wiring connections.
		Check overload reset button.
		Check overload amperage setting.
Master ROM CRC	Software mismatch.	Check motor bearings.
		Contact technical support.
		Verify spark gap. Refer to Figure 30 on page 62 .
		Faulty flame rod.
Flame Lockout	The Flame Safety Control (FSC) verifies that airflow is sensed by the airflow sensor.	Faulty FSC, replace FSC.
Max FSC Cycles Fault	FSC cycles on and off greater than 20 times in 60 minutes.	Verify heating activation, check for faulty Space/ Intake/Discharge sensor.
Intake Firestat	Intake temperature exceeds the firestat set point.	Inspect intake area of the unit for unexpected heat source.
		Reset fault with HMI.
Discharge Firestat	Discharge temperature exceed the firestat set point.	Check for faulty regulators or modulating valves.
		Reset fault with HMI.
		Inspect discharge area of the unit for unexpected heat source.
Freezestat	The discharge temperature was below the freezestat temperature set point for the duration of the freezestat timer set point.	Check gas pressure.
		Check for proper burner firing.
		Check discharge sensor values. Go to Service > Temperatures> Discharge .
		Reset fault with HMI.
High Temp Limit	Unit discharge temperature exceeds maximum limit.	Check for proper airflow.
		Measure discharge sensor (ohm reading should be 10k @ 77°F).
Fireye Alarm	Fireye detected improper burner operation.	Gas is off, turn gas on.
		Faulty ignition transformer, replace transformer.
		Faulty Fireye, replace Fireye.
		Improper flame/lighting, refer to “ Burner Troubleshooting ” on page 71.
Fireye Main	Output signal is lost between the Fireye and main gas valve during heating operation.	Check wiring between connector J30-5 to Fireye. Repair broken or loose wiring connections.
		Check wiring between connector J30-6 to the main gas valve. Repair broken or loose wiring connections.

Fault	Potential Cause	Corrective Action
Gas High PS	The board lost input on the gas pressure high terminal. There should be an input when gas pressure is at the proper level.	Adjust regulator or add regulator.
		Check wiring. Repair broken or loose wiring connections.
		Faulty high pressure gas switch, replace the switch.
Gas Low PS	The board lost input on the gas pressure low terminal. There should be an input when gas pressure is at the proper level.	Check wiring. Repair broken or loose wiring connections.
		Faulty low pressure gas switch, replace the switch.
CO Alarm	The board is receiving an input from the CO detector.	Check for proper exhaust ventilation.
		Check wiring. Repair broken or loose wiring connections.
		Faulty CO detector, replace CO detector.
Evap Water PS	Drain Closed - Water pressure should be present. The board should not receive 120VAC. A fault will occur if 120VAC is present for 5 seconds.	Verify freeze protection kit is installed. Check freeze protection kit is operational.
	Drain Open - Water pressure should not be present. The board should receive 120VAC. A fault will occur if 120VAC is not present for 15 seconds.	
Evap Float	Input signal from the evap float switch lost.	Check wiring. Repair broken or loose wiring connections.
		Clogged drain.
		Faulty float switch, replace switch.
DX Float	Input signal from the drain pan float switch lost.	Make sure the pan drain is clear and water is draining.
		Check wiring. Repair broken or loose wiring connections.
		Faulty float switch, replace the switch.
Supply VFD Comm	Modbus communication fault.	Check Modbus wiring and connections.
		Verify Modbus address.
		Verify Min and Max settings of the VFD to the MUA Board settings. Go to Factory Settings > Unit Options > Blower Config > VFD Freq Limits .
Modbus Fault VFD/MS #	VFD or MSC not connected or powered properly.	Check Modbus connections.
		Verify Modbus address is correct on VFD or MSC.
Door Interlock	Safety feature that will shut down supply fan when door signal lost.	Verify door is closed.
		Check wiring. Repair broken or loose wiring connections.
		Faulty door switch, replace the switch.
Intake Damper End/ Discharge Damper End	End limit input not received.	Check wiring. Repair broken or loose wiring connections.
		Board damper output/input failed.
		Faulty damper, replace damper.

Fault	Potential Cause	Corrective Action
Supply (Blower) Air Proving	Airflow proving pressure value is less than 0.05" w.c.	Kinked/blocked/damaged hose.
		Blockage in duct.
		Confirm proper CFM.
		Faulty airflow sensor, replace sensor.
Low PS Fault	Profile pressure is less than low profile pressure setpoint, but greater than lower pressure limit (0.05" w.c.).	Burner profile pressure out of range.
		Adjust profile pressure. Factory Settings > Unit Options > Blower Config > Air Profile Limits.
High PS Fault	Profile pressure is greater than high profile pressure setpoint.	Increase blower speed.
		Adjust profile pressure. Factory Settings > Unit Options > Blower Config > Air Profile Limits.
Clgd Fltr Mtnce	Input for clogged filters activated.	Decrease blower speed.
		Clean or replace filters.
		Check clogged filter switch adjustment.
Missing Sensor Intake/ Discharge/Space/ Outside Air/Return	When a sensor is not wired or there is an open circuit.	Faulty switch, replace switch.
		Check wiring. Repair broken or loose wiring connections.
		Install missing sensor.
Broken Sensor Intake/ Discharge/Space/ Outside Air/Return	Sensor or wiring shorted to ground.	Replace faulty sensor.
		Check wiring. Repair grounded wiring.
Broken Pressure Sensor	Pinched/missing airflow tubing. Faulty airflow sensor.	Faulty sensor, replace sensor.
RTC 1 Temp Sensor	Real-Time Clock (RTC) temperature sensor located on MUA Board.	Check tubing at the airflow pressure sensor on the MUA Board. Refer to " Board Airflow Sensor " on page 67.
HMI Temp Invalid	HMI internal temperature sensor readings incorrect.	Verify there is no damage to the MUA Board or the wiring to the MUA Board.
Proof of Closure	Input not received when there is a call for heat.	Replace HMI.
		Check wiring. Repair broken or loose wiring connections.
Low Flame Voltage	The board is receiving poor flame voltage signal.	Faulty gas valve, replace gas valve.
		Check wiring. Repair broken or loose wiring connections.
		Improper flame. Adjust pilot and low fire settings.
Communication Fault - Check Configuration	HMI communication fault or software setting.	Faulty Fireeye, replace Fireeye.
		Improper software setting. If more than one HMI is installed, check all HMIs.
		Faulty Cat 5 cable, replace cable.
HMI MB Comm		Faulty HMI, replace the HMI.
CO2 Override	High source of CO2, above PPM threshold.	Check for proper exhaust ventilation.

VFD Fault List

Refer to SMV VFD manufacturer manual for further details.

Fault Number	Description
0	No Fault
1	IGBT Temperature Fault
2	Output Fault
3	Ground Fault
4	Temperature Fault
5	Flying Start Fault
6	High DC BUS
7	Low DC BUS
8	Overload Fault
9	OEM Fault
10	Illegal Setup Fault
11	Dynamic Brake Fault
12	Phase Lost
13	External Fault
14	Control Fault
15	Start Fault
16	Incompatible Parameter Set
17	EPM Hardware Fault
18 - 27	Internal Fault
28	Remote Keypad Lost
29	Assertion Level Fault
30 - 33	Internal Fault
34	Comm. Module Failure
35 - 44	Network Fault

For i500 Series VFD Drive troubleshooting, refer to [i500 Operation Manual](#).

- Information on Status LEDs, refer to section 16.1 Status LEDs
- Information on Fault Ids, refer to section 16.6.2 Causes and Remedies
- Information on Parameters, refer to section 19.1 Parameter Attribute List

i500 Manual



Resetting Unit

If the flame safety control is locked out (alarm light on), reset the unit by:

1. Press the FSC Reset push-button, refer to **Figure 41**. If pressing the reset fails, continue to step 2.
2. Turn OFF power to the unit.
3. Turn power to the unit back ON.

Figure 41 - Reset Buttons (MUA Board)

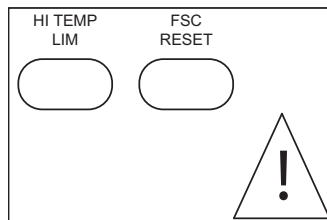

MAINTENANCE

To guarantee trouble-free operation of this heater, the manufacturer suggests following these guidelines. Most problems associated with fan failures are directly related to poor service and maintenance.

Please record any maintenance or service performed on this fan.

WARNING: DO NOT ATTEMPT MAINTENANCE ON THE HEATER UNTIL THE ELECTRICAL SUPPLY HAS BEEN COMPLETELY DISCONNECTED AND THE MAIN GAS SUPPLY VALVE HAS BEEN SHUT OFF.

General Maintenance

- Fan inlet and approaches to ventilator should be kept clean and free from any obstruction.
- All fasteners and electrical connections should be checked for tightness each time maintenance checks are performed before restarting unit.
- These units require very little attention when moving clean air. Occasionally oil and dust may accumulate, causing imbalance. If the fan is installed in a corrosive or dirty atmosphere, periodically inspect and clean the wheel, inlet, and other moving parts to ensure smooth and safe operation.
- Motors are normally permanently lubricated. **CAUTION: Use care when touching the exterior of an operating motor. Components may be hot enough to burn or cause injury.**
- If bearings require lubrication, very little is needed. A general rule is one-half pump from a grease gun for 1/2" to 1-7/16" shaft diameters and one full pump for 1-11/16" and large diameter shafts for every 1500 to 3000 hours of operation. A lithium-based grease should be used. Bearings should be rotated as they are lubricated to evenly distribute the grease, either by hand or via extended grease lines. Do not attempt to grease bearings from inside the enclosure while the motor is energized. **CAUTION: Bearings are sealed, over-greasing can cause damage to the bearings. Do not grease until grease comes out of seals. Only add the appropriate amount of grease.**

2 Weeks After Start-up

- All fasteners should be checked for tightness when maintenance checks are performed before restarting unit.
- For belt drive units, belt tension should be checked after the first 2 weeks of fan operation. **See "Pulley Alignment/Proper Belt Tension" on page 58.**

Every 3 Months

- Filters need to be cleaned and/or replaced quarterly, and more often in severe conditions. Washable filters can be washed in warm soapy water. When re-installing filters, be sure to install with the **airflow in the correct direction** as indicated on the filter.
- All fasteners should be checked for tightness when maintenance checks are performed before restarting unit.
- Belt tension should be checked quarterly. **See "Pulley Alignment/Proper Belt Tension" on page 58.** Over-tightening will cause excessive bearing wear and noise. Too little tension will cause slippage at start-up and uneven wear.

Yearly

- Inspect bolts and screws. Secure and tighten as necessary.
- Inspect motor for cleanliness. Clean exterior surfaces only. Remove dust and grease from the motor housing to ensure proper motor cooling.
- Remove dirt and grease from the wheel and housing to prevent imbalance and damage.
- Check for gas leak and repair if present.
- Clean flame sensor by rubbing with steel wool to remove any rust build-up.
- Inspect bearings for wear and deterioration. Replace if necessary.
- Inspect belt wear and replace torn or worn belts.
- Inspect the unit assembly. Check all modules, curbs, and mounting equipment (rails/Uni-Strut).
- For heating season, inspect the burner assembly.
- For cooling season, inspect the cooling module. Refer to cooling manufacturer's recommendations.

Burner Maintenance

Burner maintenance should be performed annually when entering heating season.

- Verify the unit is off.
- Inspect the pilot assembly, refer to “**Pilot Adjustment**” on page 63. Replace if required.
- Inspect the burner plates.
- Clean the burner plates. Make sure the baffles are secure and attached to the burner.
- Clean burner with wire brush and make sure the burner ports are free of debris. Refer to **Table 10** for drill size(s) to clear ports. Wipe the burner with a clean rag.
- After cleaning the system, turn the system. Visually inspect the flame.

Table 10 - Burner Orifice Drill Size

Orifice	Drill Size
Gas Port	1/8"
Air Port	42

Unit Filters

Table 11 - Filter Quantity Chart

Intake	16" x 20"	20" x 25"
Size 1 Standard Sloped	2	-
Size 2 Standard Sloped	-	2
Size 1 Modular Sloped	3	-
Size 2 Modular Sloped	-	3
Size 3 Modular Sloped	6	-
Size 4 Modular Sloped	10	-
Size 5 Modular Sloped	-	8
Size 1 V-Bank	-	3
Size 2 V-Bank	8	-
Size 3 V-Bank	-	8
Size 4 V-Bank	15	-
Size 5 V-Bank	-	12
Size 1 Inline	1	-
Size 2 Inline	-	1
Size 3 Inline	-	2

To order Filters, Scan the QR Code:



Emergency Shutdown of Unit

To shutdown the unit in the event of an emergency, do the following:

1. Turn power OFF to the unit from main building disconnect.
2. Turn the external disconnect switch to the OFF position.
3. CLOSE the inlet gas valve located on the heater.

Prolonged Shutdown of Unit

For prolonged shutdown, the following steps should be done:

1. Turn the external disconnect switch to the OFF position.
2. CLOSE the inlet gas valve located on the heater.

To re-start the unit, the following steps should be done:

1. Turn the external disconnect switch to the ON position.
2. OPEN the inlet gas valve located on the heater.

Start-Up Documentation

START-UP AND MEASUREMENTS SHOULD BE PERFORMED AFTER THE SYSTEM HAS BEEN AIR BALANCED AND WITH THE HEAT ON (Warranty will be void without completion of this form)

Job Information

Job Name		Service Company	
Address		Address	
City		City	
State		State	
Zip		Zip	
Phone Number		Phone Number	
Fax Number		Fax Number	
Contact		Contact	
Purchase Date		Start-up Date	

Heater Information

Refer to the start-up procedure in this manual to complete this section.

Name Plate and Unit Information		Field Measure Information	
Model Number		Motor Voltage	
Serial Number		Motor Amperage**	
Hardware Rev.		RPM	
Software Rev.		Burner Differential Pressure	Inches WC
Motor Volts		Pilot Flame Signal	VDC
Motor Hertz		Low Fire Flame Signal	VDC
Motor Phase		High Fire Flame Signal	VDC
Motor FLA		High Fire Inlet Gas Pressure	Inches WC
Motor HP		Low Fire Manifold Gas Pressure	Inches WC
Min. Btu/Hr		High Fire Manifold Gas Pressure	Inches WC
Max. Btu/Hr		Thermostat Set Point	
Gas Type		Gas Type	

**If measured amps exceed the FLA rating on the nameplate, fan RPM must be reduced to decrease the measured amps below the nameplate FLA rating.

Temperature Control	Discharge		Activate Based On	Space	
	Space			Intake	
Airflow Direction	Correct			Both	
	Incorrect			Either	

As a result of our dedication to constant improvements and quality, the MANUFACTURER reserves the right to update specifications without notice. Please refer to MANUFACTURER'S website for up to date documentation.

Technical Support Information

CASLink



Technical Support



Parts Store

